

ISUZU

TFR/TFS

TFR/TFS

OWNER'S AND DRIVER'S MANUAL[Ⓔ]

Trucks for life
ISUZU



PICTORIAL INDEX

VEHICLE INFORMATION

IMPORTANT INFORMATION

PRE-DRIVING OPERATIONS AND ADJUSTMENTS

CONTROLS AND INSTRUMENTS

COMFORT AND CONVENIENCE

SERVICE AND MAINTENANCE

IN CASE OF EMERGENCY

MAIN DATA

INDEX

OWNER'S AND DRIVER'S MANUAL[Ⓔ]

ISUZU MOTORS LIMITED









Ⓔ No.TF-IE-1761E56
Printed in Thailand

2017

Keep this Owner's Manual in the vehicle for handy reference whenever needed.

- We recommend that you also read the separate instructions for the equipment on your vehicle that was installed by your Isuzu Dealer.
- Your Isuzu Dealer will be glad to answer any questions you may have about the information in this manual.
- Please leave this manual in the vehicle when you resell it – the next owner will need it.

Notes on Reading This Manual

- Please read this manual carefully, especially the information in the "IMPORTANT INFORMATION" section and the instructions and information identified by the following symbol/letter combinations:
 **DANGER**,  **WARNING**,  **CAUTION**,  **ADVICE** and  **NOTE**.
 Among them,  **DANGER**,  **WARNING** and  **CAUTION** are reminders to be especially careful. Failure to follow or wrongly following the associated instructions could result in personal injury or accidents. Please read them thoroughly.
- Throughout this manual, illustrations are primarily based on right-hand drive models.
- Due to differences in vehicle specifications, the illustration used for description may not match your vehicle.
- The contents of this manual are current at the date of issue, but may differ slightly from your vehicle due to specification changes or other modifications made thereafter.
- The equipment that is mentioned in this manual may not be equipped depending on the vehicle specifications. Please check your vehicle specifications and read this manual.
- This manual is applicable for vehicle in all countries except the USA and Canada.
- All rights reserved. This manual may not be reproduced in whole or in part, without the permission in writing of ISUZU MOTORS LIMITED.

Published: Nov., 2016
 Printed: Nov., 2016
 First Edition

All rights reserved.

ISUZU **TFR/TFS** **OWNER'S AND DRIVER'S MANUAL**

Issued by ISUZU MOTORS LIMITED
 Service Technical & Training Dept.
 Shinagawa-ku, Tokyo, 140-8722 Japan

The authorized representative of the manufacturer in Europe
 Homologation and Engineering Department
 ISUZU MOTORS Europe, NV
 Bist 12,
 2630 Aartselaar, Belgium

171611-01K-x

Symbols Used in This Manual



DANGER

Failure to follow these instructions identified by this symbol could result in death or serious injury to you and/or other people.



WARNING

Failure to follow these instructions identified by this symbol could result in a fire inside your vehicle in addition to death or serious injury to you and/or other people.



CAUTION

Failure to follow these instructions identified by this symbol could result in injuries or an accident.



ADVICE

Failure to follow these instructions identified by this symbol could cause malfunction or damage to your vehicle.



NOTE

This symbol identifies information that you need to know.

Abbreviations

This manual uses the following abbreviations, as interpreted below.

Abbreviations	Description
ABS	Anti-lock Brake System
ACEA	Association des Constructeurs Européens d'Automobiles (Association of European Automobile Constructors)
API	American Petroleum Institute
BS	British Standards
CRS	Child Restraint System
DIN	Deutsche Industrie Normen
DPD	Diesel Particulate Defuser
EBD	Electronic Braking force Distribution
ECE	Economic Commission for Europe
ELR	Emergency Locking Retractor
ESC	Electronic Stability Control
FMVSS	Federal Motor Vehicle Safety Standards
GAW	Gross Axle Weight
GCW	Gross Combined Weight
GSI	Gear Shift Indicator
GVW	Gross Vehicle Weight
GWP	Global Warming Potential
IBS	Intelligent Battery System
JASO	Japanese Automobile Standards Organization
LCD	Liquid Crystal Display
LLC	Long Life Coolant
MID	Multi-Information Display
MIL	Malfunction Indicator Light
PM	Particulate Matter

Abbreviations	Description
r/min	revolutions per minute
SAE	Society of Automotive Engineers
SRS	Supplemental Restraint System
SVS	Service Vehicle Soon
TCS	Traction Control System
UN	United Nations
VIN	Vehicle Identification Number
WMI	World Manufacturer Identifier
2WD	Two Wheel Drive
4WD	Four Wheel Drive

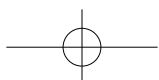
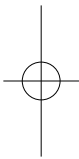
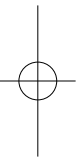
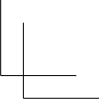
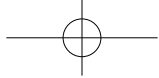
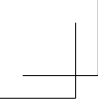

HOW TO USE THIS MANUAL AND HOW TO FIND A SPECIFIC TOPIC

0

• HOW TO USE THIS MANUAL	0-2
• HOW TO FIND A SPECIFIC TOPIC	0-3
• CHAPTER DESCRIPTION	0-5
• PICTORIAL INDEX	0-6
• WARNING/INDICATOR LIGHT INDEX	0-16
• WARNING/CAUTION LABELS	0-26

Chapter/section titles

These titles are useful for getting the gist of the content at a glance.

Chapter index tab

Use this for quick access to your desired chapter.

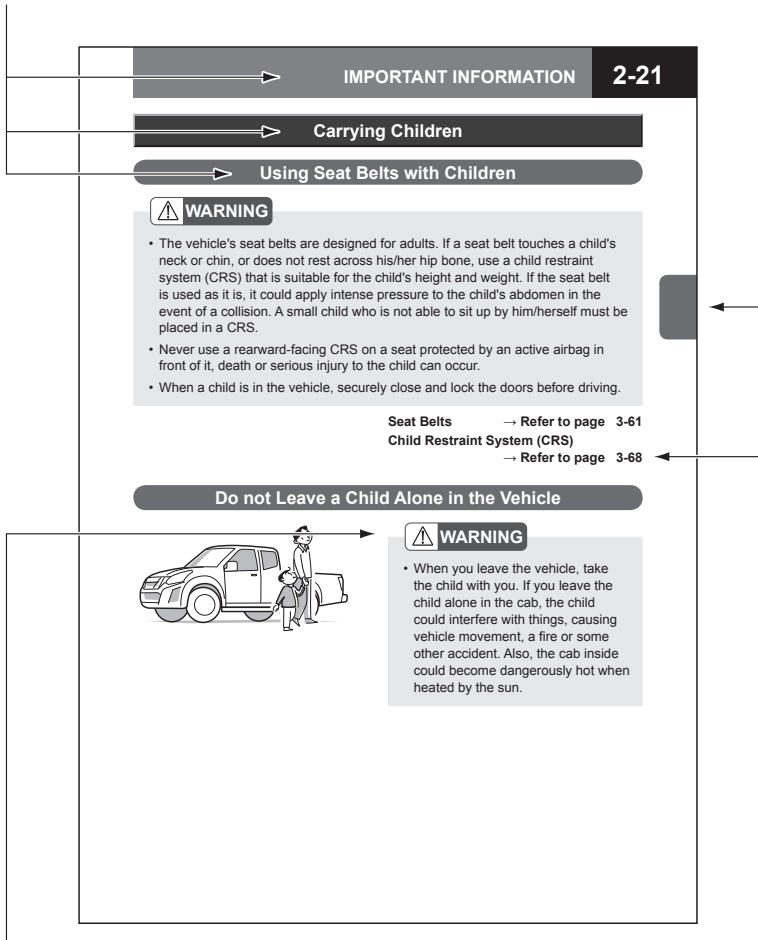

- DANGER**
- WARNING** **CAUTION**
- ADVICE** **NOTE**

Symbols

See the preceding page for the meanings of these symbols.

Reference page

Refers you to a page (or pages) of this manual that concerns the present topic and that you should also read.

All values in this manual are indicated primarily according to the International System of Units (or in SI units) with the conventional metric values and American units indicated in parentheses.

Note: This page is shown only as an example. It is not intended to give you information on your particular vehicle.

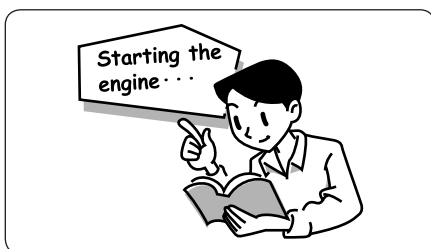

Use chapter/section titles as keys ➔ Page 0-5

Search for the page describing the specific topic by using the general table of contents under CHAPTER DESCRIPTION, the CHAPTER INDEX, and/or the TABLE OF CONTENTS on the first page of each chapter.

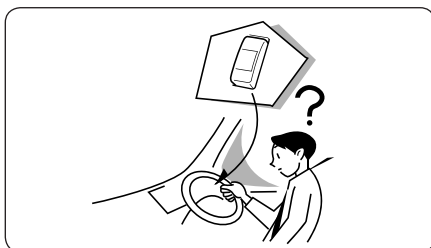

Use the pictorial indexes ➔ Pages 0-6 to 0-15

If you do not know the name of the switch or other device for which you need information, locate the page describing it by using the pictorial indexes.

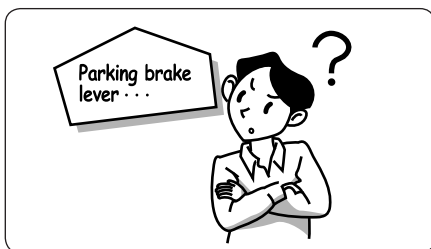

Use device names as keys ➔ Pages 9-1 to 9-4

If you know the name of the switch or other device for which you need information, locate the page describing it by using the index at the end of this manual.

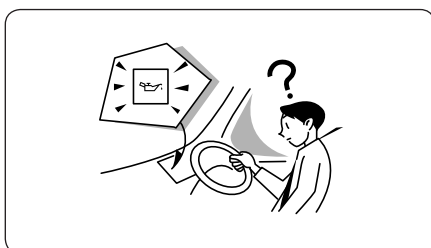

Use the Warning/Indicator Light Index ➔ Pages 0-16 to 0-25

If a warning or indicator light is illuminated, you can use the WARNING/INDICATOR LIGHT INDEX to find the page that provides information on the light.

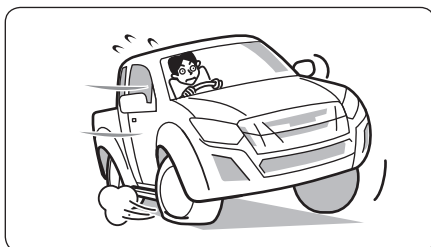

If you have a problem with your vehicle ➔ Pages 7-2 to 7-62

Refer to IN CASE OF EMERGENCY to find measures to take.

0-4



PICTORIAL INDEX 0-6**VEHICLE INFORMATION 1****IMPORTANT INFORMATION 2**

Describes what you should know before you can operate the vehicle safely and smoothly.

PRE-DRIVING OPERATIONS AND ADJUSTMENTS .. 3

Shows the proper way to open/close the doors, windows and fuel tank filler cap. Also explains how to adjust the mirrors, seats and steering including how to correctly fasten the seat belts.

CONTROLS AND INSTRUMENTS 4

Explains how to start and stop the engine. Also describes various controls and instruments.

COMFORT AND CONVENIENCE 5

Contains information on the air conditioning system, and other comfort and convenience features.

SERVICE AND MAINTENANCE 6

Describes daily and periodic inspections and other vehicle care and maintenance information necessary to keep your vehicle in good condition.

IN CASE OF EMERGENCY 7

Enumerates possible emergency situations and describes the actions you should take to deal with any one of them.

MAIN DATA 8**INDEX 9**

Interior

Right-hand Drive

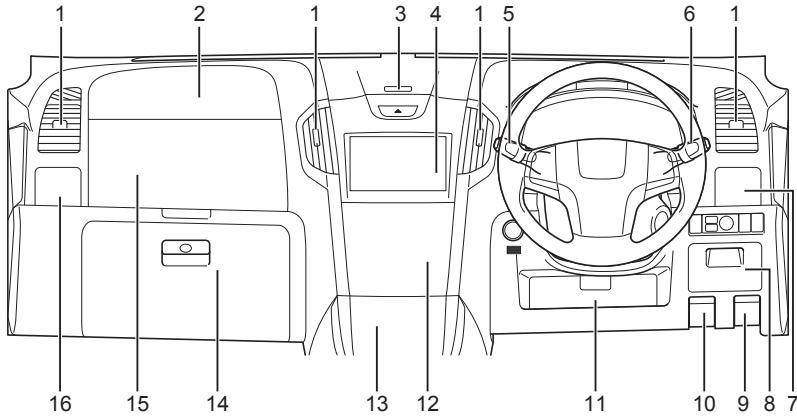

No.	Equipment	Page
1	Air flow direction control tab	5-3
2	Passenger's SRS airbag	3-80
3	Small article storage pocket (upper side of dashboard)	5-41
	Dashboard tray	5-41
4	Small article storage pocket (center of instrument panel)	5-38
	Audio system	—
5	Combination light control switch	4-121

No.	Equipment	Page
6	Windshield wiper and windshield washer switch	4-127
7	Cup holder and small article storage pocket (driver's side)	5-45
8	Small article storage pocket (driver's side)	5-42
	Fuse box	7-46
9	Fuel lid opener	3-46
10	Engine hood release lever	6-11
11	Small article storage pocket (lower part of driver's side)	5-38

No.	Equipment	Page
12	Heater/manual air conditioner	5-15
	Automatic air conditioner	5-4
13	Small article storage pocket (lower part of center of instrument panel)	5-38
	Cigarette lighter	5-32
14	Glove compartment	5-40

No.	Equipment	Page
15	Small article storage pocket (passenger's side)	5-39
	Accessory socket	5-34
16	Cup holder and small article storage pocket (passenger's side)	5-45



Left-hand Drive

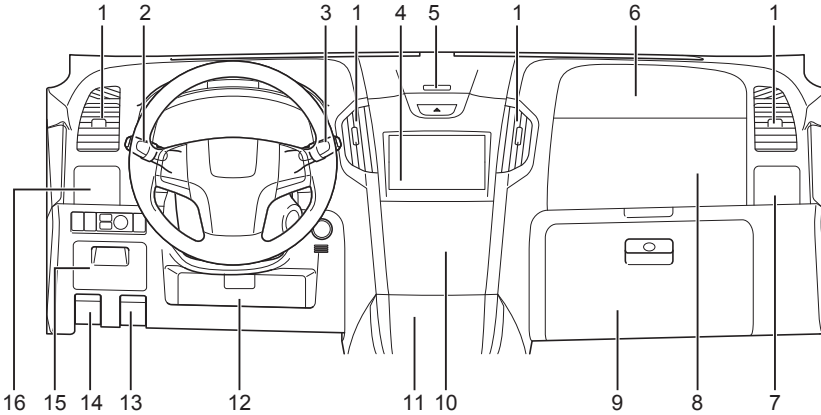

No.	Equipment	Page
1	Air flow direction control tab	5-3
2	Combination light control switch	4-121
3	Windshield wiper and windshield washer switch	4-127
4	Small article storage pocket (center of instrument panel)	5-38
	Audio system	—
5	Small article storage pocket (upper side of dashboard)	5-41
	Dashboard tray	5-41

No.	Equipment	Page
6	Passenger's SRS airbag	3-80
7	Cup holder and small article storage pocket (passenger's side)	5-45
8	Small article storage pocket (passenger's side)	5-39
	Accessory socket	5-34
9	Glove compartment	5-40
10	Heater/manual air conditioner	5-15
	Automatic air conditioner	5-4

No.	Equipment	Page
11	Small article storage pocket (lower part of center of instrument panel)	5-38
	Cigarette lighter	5-32
12	Small article storage pocket (lower part of driver's side)	5-38
13	Engine hood release lever	6-11

No.	Equipment	Page
14	Fuel lid opener	3-46
15	Small article storage pocket (driver's side)	5-42
	Fuse box	7-46
16	Cup holder and small article storage pocket (driver's side)	5-45

Right-hand Drive

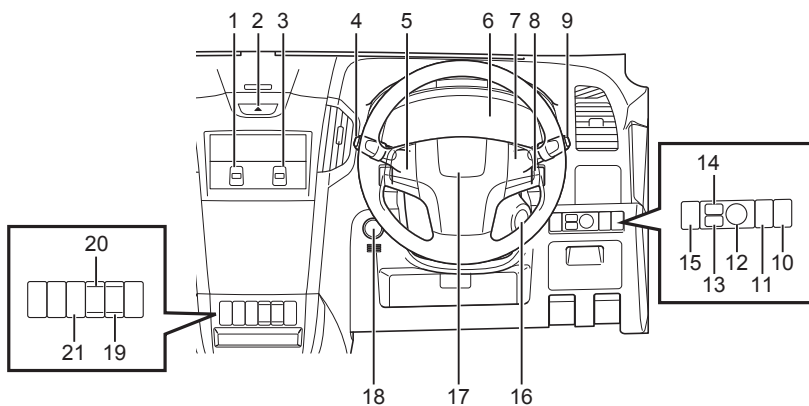

No.	Equipment	Page
1	Passenger side window switch	3-43
2	Hazard warning flasher switch	4-126
3	Driver side window switch	3-43
4	MID mode L switch	4-37
5	Steering wheel remote control	5-51
6	Instruments, warning lights and indicator lights	4-16 4-26

No.	Equipment	Page
7	Cruise control resume switch	4-155
	Cruise control set switch	4-154
	Cruise control main switch	4-154
	Cruise control cancel switch	4-156
8	ESC OFF switch	4-165
9	MID mode R switch	4-37
10	Headlight leveling switch	4-124
11	Illumination control switch	4-131
12	Remote control mirror switch (angle adjustment switch)	4-129
13	Retractable power mirror switch	4-130

No.	Equipment	Page	No.	Equipment	Page
14	Remote control mirror switch (left/right selector switch)	4-129	18	Engine start/stop button (models with passive entry and start system)	4-116
15	Hill descent control switch	4-173	19	Heated seat switch (right front seat)	4-132
16	Starter switch (models without passive entry and start system)	4-119	20	Heated seat switch (left front seat)	4-132
17	Horn button	4-129	21	USB power outlet	5-35
	Driver's SRS airbag	3-80			

Left-hand Drive

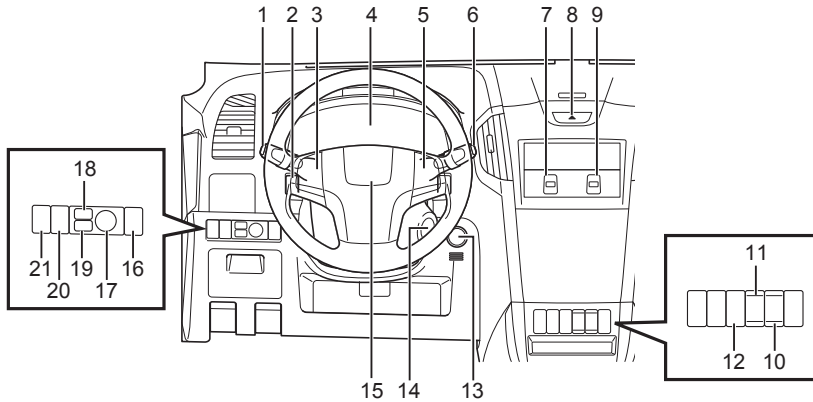

No.	Equipment	Page
1	MID mode L switch	4-37
2	ESC OFF switch	4-165
3	Steering wheel remote control	5-51
4	Instruments, warning lights and indicator lights	4-16 4-26
5	Cruise control resume switch	4-155
	Cruise control set switch	4-154
	Cruise control main switch	4-154
	Cruise control cancel switch	4-156
6	MID mode R switch	4-37
7	Driver side window switch	3-43

No.	Equipment	Page
8	Hazard warning flasher switch	4-126
9	Passenger side window switch	3-43
10	Heated seat switch (right front seat)	4-132
11	Heated seat switch (left front seat)	4-132
12	USB power outlet	5-35
13	Engine start/stop button (models with passive entry and start system)	4-116
14	Starter switch (models without passive entry and start system)	4-119

No.	Equipment	Page
15	Horn button	4-129
	Driver's SRS airbag	3-80
16	Hill descent control switch	4-173
17	Remote control mirror switch (angle adjustment switch)	4-129

No.	Equipment	Page
18	Remote control mirror switch (left/right selector switch)	4-129
19	Retractable power mirror switch	4-130
20	Illumination control switch	4-131
21	Headlight leveling switch	4-124

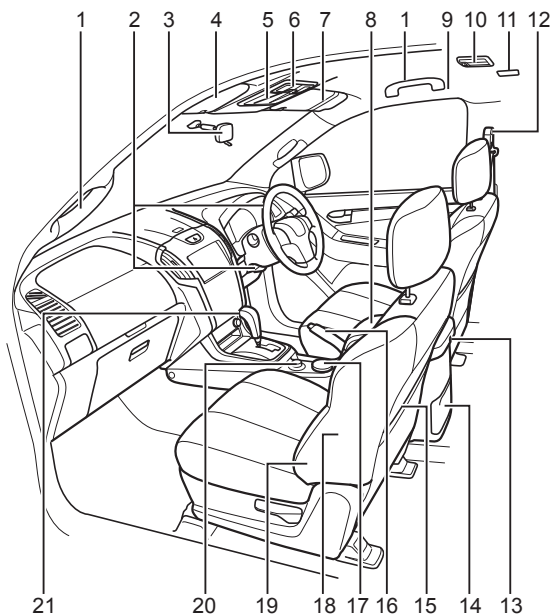

No.	Equipment	Page
1	Grips	3-38 5-47
2	Tilt steering	3-58
3	Inside rearview mirror	3-59
4	Sun visor	5-31
5	Overhead console	5-30
6	Map lights	5-28
7	Ticket holder	5-31
8	Center console box	5-43
9	Curtain airbag	3-80
10	Dome light	5-26
11	Roof speaker	—
12	Seat belts	3-61

No.	Equipment	Page
13	USB power outlet	5-35
14	Cup holder	5-44
15	Small article storage pocket	5-38
16	Parking brake lever	4-137
17	Ashtray	5-37
	Cup holder	5-44
18	Side airbag	3-80
19	Seats	3-48
20	4WD switch	4-177
21	Gearshift lever (manual transmission model)	4-138
	Selector lever (automatic transmission model)	4-141

Exterior

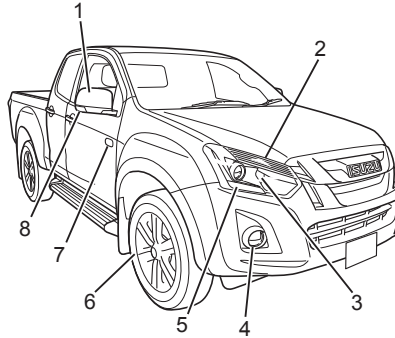









No.	Equipment	Page
1	Outside rearview mirrors	3-60
2	Turn signal light	7-35
3	Headlight	7-35
4	Front fog light	7-35
5	Clearance light/daytime running light	7-35



No.	Equipment	Page
6	Tires	6-63
7	Turn signal light (front door mounted type)	7-35
8	Turn signal light (outside rearview mirror mounted type)	7-35

Warning/Indicator Light Index



Multi-Information Display (MID)





Warning Lights

Message	Display indication	Page
Overheat	 OVER HEAT	4-78
Parking brake release	 RELEASE PARK BRAKE	4-74
Low fuel	 LOW FUEL	4-89
Water separator	 WATER SEPARATOR	4-85
Checking PM level	 CHECKING PM LEVEL	4-110
Light control OFF		4-90
Key remain (models without passive entry and start system)		4-90
No electronic key (models with passive entry and start system)		4-91

Message	Display indication	Page
Steering wheel lock not released (models with passive entry and start system)	 <p>PUSH START BUTTON WHILE TURNING STEERING WHEEL</p>	4-93
Door open (models with passive entry and start system)	 <p>DOOR OPEN</p>	4-93













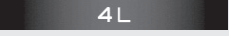



Message	Display indication	Page
<p>Shift position (models with passive entry and start system)</p>	 <p>SHIFT TO N</p>	<p>4-94</p>
	 <p>SHIFT TO P</p>	
	<p>TO POWER OFF SHIFT TO P THEN PUSH START BUTTON</p>	
<p>Turn off the power (models with passive entry and start system)</p>	 <p>TURN OFF THE POWER</p>	<p>4-95</p>





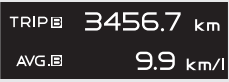





Message	Display indication	Page
<p>Low battery electronic key (models with passive entry and start system)</p>		<p>4-96</p>
<p>Check system (models with passive entry and start system)</p>		<p>4-97</p>
<p>Power management system (models with passive entry and start system)</p>		<p>4-98</p>
<p>Steering wheel lock system (models with passive entry and start system)</p>		<p>4-99</p>



Indicator Lights

Message	Display indication	Page
2H (2WD)		4-108
4H (4WD)		4-107
4L (4WD low)		4-108
Cruise main power		4-106
Cruise set		4-106
Hill descent control		4-109
Accessory mode (models with passive entry and start system)		4-100
		

Message	Display indication	Page
Low battery engine starting (models with passive entry and start system)	 <p>PUT ELECTRIC KEY CLOSE TO START BUTTON</p>	4-101
	<p>INFORMATION</p> <p>TO START STEP TO THE CLUTCH AND SHIFT TO N THEN PUSH START BUTTON</p>	
	<p>INFORMATION</p> <p>TO START STEP TO THE BRAKE THEN PUSH START BUTTON</p>	
Odometer and trip meter A		4-18
Trip meter B and trip meter B section average fuel economy		4-19
Instantaneous fuel economy and average fuel economy (numerical display)		4-40
Instantaneous fuel economy and average fuel economy (graphical display)		4-40
Average fuel economy and driving distance		4-40













Message	Display indication	Page
Average vehicle speed and driving distance		4-41
Elapsed time and driving distance		4-41
Range (possible driving range)		4-41
Select mode		4-45
Engine oil		4-79
Air cleaner element		4-80
Distance to maintenance		4-81
Service reminder OFF		4-48 4-49 4-50
Illumi level		4-44
DPD PM level		4-42
Progress of DPD regeneration		4-42







**NOTE**

- The unit of distance is indicated using "km" and the vehicle speed is indicated using "km/h" if the speedometer is graduated in kilometer units. The unit of distance is indicated using "miles" and the vehicle speed is indicated using "mph" if the speedometer is graduated in both mile and kilometer units.







Instrument Panel











Warning Lights

Name	Symbol	Color	Page
Malfunction indicator light (MIL)		Amber	4-83
SVS indicator light		Amber	4-84
Engine oil pressure warning light		Red	4-77
Engine overheat warning light		Red	4-78
Fuel filter warning light		Amber	4-86
Water separator warning light		Amber	4-85
Low fuel warning light		Amber	4-89
Generator warning light		Red	4-82
Brake system/parking brake warning light		Red	4-73
ABS warning light		Amber	4-75
ESC warning light		Amber	4-76
SRS airbag warning light		Red	4-72
Seat belt warning light (driver seat)		Red	4-70

Name	Symbol	Color	Page
Seat belt warning light (front passenger seat)		Red	4-71
Door open warning light		Red	4-90
Automatic transmission fluid temperature warning light		Red	4-87
CHECK 4WD warning light		Red	4-87
Check trans warning light		Amber	4-86
Passive entry and start system warning light		Red	4-91
Icy road warning light (models with MID)		—	4-88

Indicator Lights

Name	Symbol	Color	Page
Glow plug indicator light		Amber	4-103
DPD operator regeneration indicator light		Amber	4-110
High beam indicator light		Blue	4-102
Light position indicator light		Green	4-102
Turn signal indicator light – left		Green	4-102
Turn signal indicator light – right		Green	4-102

Name	Symbol	Color	Page
Front fog light indicator light		Green	4-103
Rear fog light indicator light		Amber	4-103
TCS OFF indicator light		Amber	4-104
ESC OFF indicator light		Amber	4-105
Hill descent control indicator light (models with MID)		—	4-109
Hill descent control indicator light (models with LCD)		Green	4-109
4WD indicator light		—	4-107
4WD low indicator light		—	4-108
Cruise control main indicator light		—	4-106
Cruise control set indicator light		—	4-106



Warning/Caution Labels in Your Vehicle

- The warning/caution labels in your vehicle indicate very important instructions and information that you should respect to ensure safe and proper use of the vehicle. Be sure to read them before using the vehicle.
- If any of these labels are peeling or illegible due to wear or scratches, please contact your Isuzu Dealer for a replacement.
- Some examples of warning/caution labels are indicated on the following pages, but there are many others not shown. Also, the contents of these labels may vary from model to model.
- The warning/caution labels indicated may be located differently in your vehicle.

Warning/Caution Labels – Cab Interior

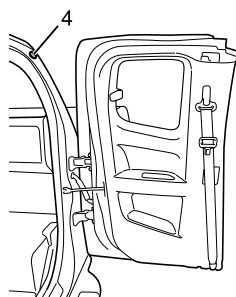
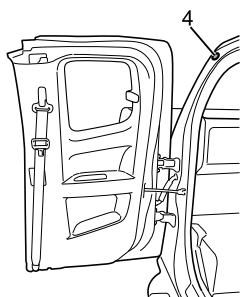
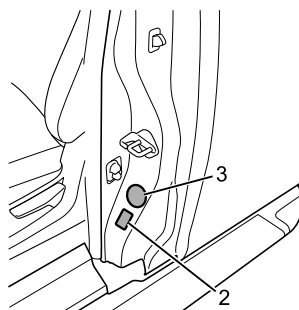
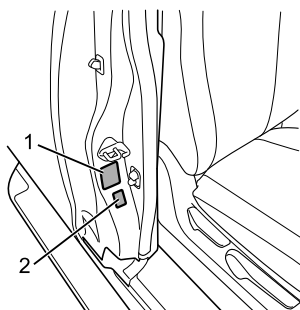

No.	Description
1	Tire air pressure (Driver's side)
2	Side airbag
3	Passenger's SRS airbag (Passenger's side)
4	Warning to avoid trapped hands in side access panel (Extended cab model)

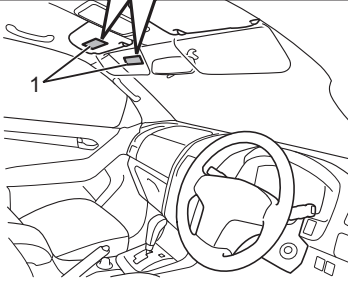

No.	Description
1	Passenger's SRS airbag

WARNING

- Never use a rearward-facing CRS on a seat protected by an active airbag in front of it, death or serious injury to the child can occur.

Child Restraint System (CRS)

→ Refer to page 3-68

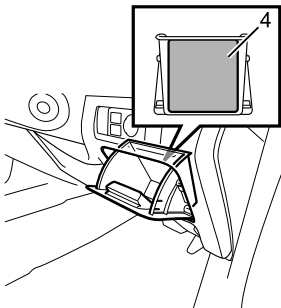
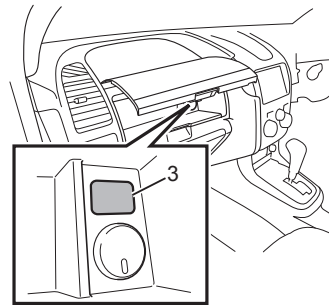
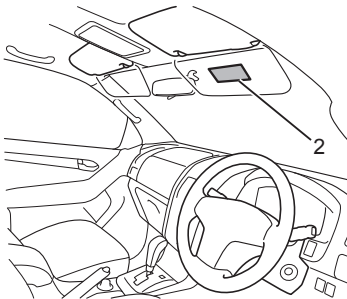

No.	Description
2	2WD - 4WD selection
3	Accessory socket
4	Fuse

Warning/Caution Labels – Engine Compartment

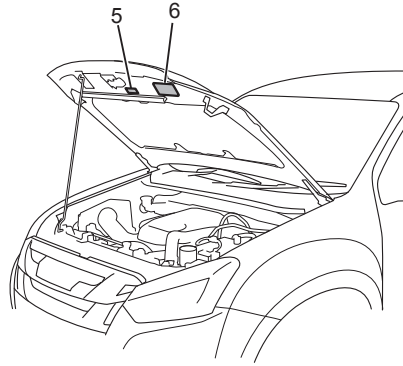
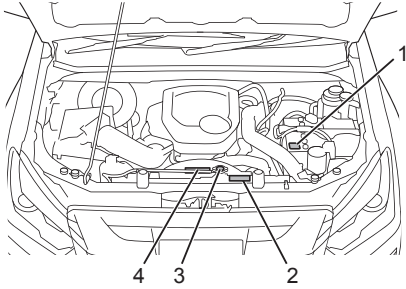

No.	Description
1	Battery
2	Engine coolant (4JK1 engine model)
3	Radiator cap
4	Engine coolant (RZ4E engine model)
5	Exhaust emission
6	Engine maintenance

VEHICLE INFORMATION

1

-
- **Vehicle Identification Number (VIN) and Engine Number** 1-2
-

Vehicle Identification Number (VIN) and Engine Number

The VIN and engine number are necessary for registering your vehicle. They are also necessary when your vehicle undergoes official inspections. Provide your Isuzu Dealer with these numbers when you are having the vehicle repaired or are ordering replacement parts. The Dealer will be able to do the requested jobs more competently and quickly.

VIN

VIN Location on Frame

The VIN is stamped on the right side center part of the frame.

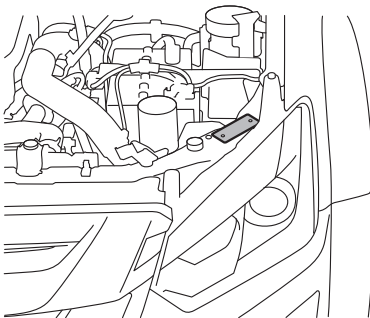
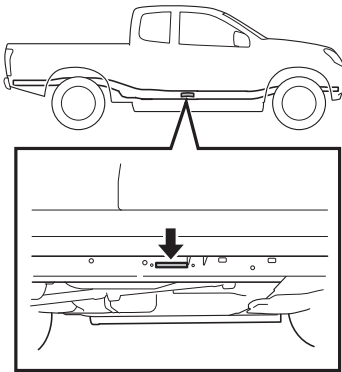

VIN Plate (Engine Compartment)

The VIN plate at the upper surface of the radiator sill in the engine compartment indicates information such as the VIN.



VIN Plate (Front Left Side of Windshield)

The VIN plate is located in the front left side of the windshield.



ADVICE

- This VIN plate is equipped only on models for the European and Turkey markets.

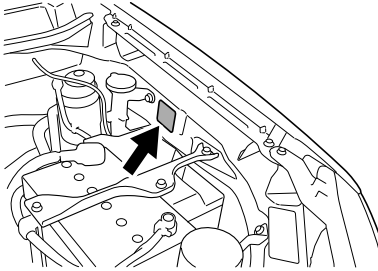

ID Plate

The ID plate at the left side of engine compartment indicates the VIN together with other information such as option codes.

1-4

VEHICLE INFORMATION

The VIN contains multiple pieces of information including the vehicle and engine model codes as shown below.

M	P	A	T	F	R	8	7	J	H	T	0	0	0	0	0	1
1			2				3		4		5					

Section	Description
1	World Manufacturer Identifier (WMI)
2	Model code TFR86J: 4 × 2, Long wheel base, 4JK1 engine model TFS86J: 4 × 4, Long wheel base, 4JK1 engine model TFR87J: 4 × 2, Long wheel base, RZ4E engine model TFS87J: 4 × 4, Long wheel base, RZ4E engine model
3	Model year code H: 2017 model J: 2018 model K: 2019 model L: 2020 model M: 2021 model N: 2022 model
4	Plant code
5	Production sequential number



ADVICE

- Interpretation of the VIN may differ depending on the market. For further details, please ask your Isuzu Dealer.

Option Codes

The ID plate also indicates option codes. These codes are three-digit, alphanumeric codes, each assigned to a particular component of the vehicle.

You will be able to use these codes to identify the model or type of engine, transmission or other components when your vehicle needs inspection and other services.

Option Codes	Engine
LNC	RZ4E-TCX HI-POWER
RDX	4JK1-TCY HIHI-POWER

Option Codes	Suspension
7YC	2WD High-Ride
G50	Rear, heavy duty

Option Codes	Automatic air conditioner
C61	Air conditioner (cooler and heater)

Option Codes	Other components
UGQ	Radio and CD/USB player with Bluetooth®
UVA	Radio and CD/DVD/USB player with Bluetooth®
8QK	Radio and CD/DVD/USB player with Bluetooth® and smart phone connect
NW9	Electronic stability control
K30	Cruise control

Option Codes	Heater/manual air conditioner
C42	Heater (without cooler)
C60	Air conditioner (cooler and heater)

Option Codes	Transmission
RNU	AY6
MA1	TB-50LS
Y5Z	MVL6N
Y6A	AWR6B45



ADVICE

- There are more option codes than those indicated above. Depending on the market, an option code may not be shown. For detailed specifications of your vehicle, please ask your Isuzu Dealer.

Engine Number

4JK1 engine model

The engine number is stamped on the right side rear part of the engine block.

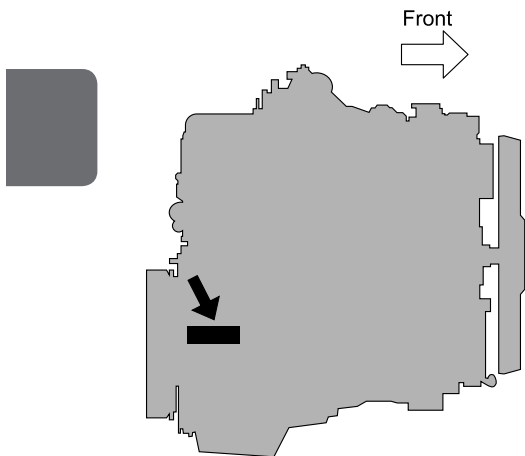

RZ4E engine model

The engine number is stamped on the left side rear part of the engine block.

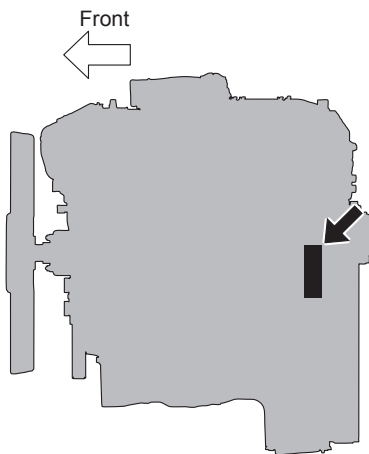

IMPORTANT INFORMATION

2

• Before Driving	2-2
• Carrying Children	2-21
• Driving	2-23
• Off-road Driving	2-41
• Automatic Transmission Model	2-42
• Four Wheel Drive (4WD) Model	2-46
• Stopping and Parking	2-49
• Cautions for Driving in Hot Regions	2-57
• Cautions for Driving in Cold Regions	2-58
• Staying Safe	2-62
• Preventing Breakdowns	2-66
• When to Visit Your Isuzu Dealer	2-69
• Using Tire Chains	2-72
• Diesel Particulate Defuser (DPD)	2-73
• Speed Limit Device	2-76
• Front Seat Belt with Pretensioner and SRS Airbag System	2-77
• Vehicle Data Collection	2-82
• Turbocharger	2-82

This chapter contains information and cautions that you should observe for safe and comfortable vehicle operation. Be sure to read it before using the vehicle.

Before Driving

Proper care and driving is important not only in extended service life of your vehicle, but also in improved fuel and oil economy. Drive carefully and defensively.

Perform Daily (Pre-operation) Inspections

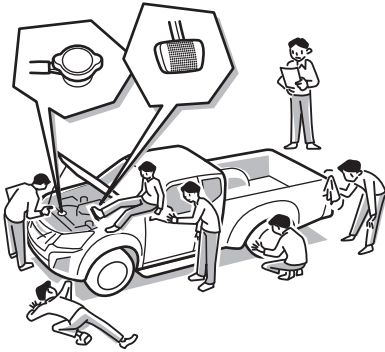

ADVICE

- For safe and comfortable driving, keep record of the distances driven and the condition of the vehicle during operation. Perform inspections at appropriate intervals, and perform maintenance in accordance with the findings of the inspections. If an inspection reveals an abnormality or there was an abnormality the previous time the vehicle was driven, have the vehicle repaired by the nearest Isuzu Dealer before it is driven again.

[1. Checking components that showed abnormalities during the previous operation]

Check item	Reference page
Checking components that showed abnormalities during the previous operation	6-16

[2. Checks performed with the engine hood opened]

Check item	Reference page
Fan belt looseness and damage	6-47
Engine oil level	6-20
Engine coolant level and radiator cap looseness	6-40
Power steering fluid level	6-93
Brake fluid level (For a manual transmission model, brake fluid doubles as clutch fluid.)	6-58, 6-90
Windshield washer fluid level	6-96
Battery fluid level	6-101

[3. Checks performed in the driver's seat]

Check item	Reference page
Brake pedal free play	6-60
Operation of meters, gauges and warning/indicator lights	4-16, 4-26
Engine startability, abnormal noise and color of exhaust gases	6-18
Parking brake lever stroke	6-63
Windshield washer fluid spray condition and windshield wiper effectiveness	6-96, 6-97
Rearview mirror condition	3-59
Steering wheel free play and mounting condition	3-58, 6-92
Operation of horn and turn signal lights	4-123, 4-129
Fuel level	4-23
Operation of door locks	3-7, 3-13, 3-26

[4. Checks performed during a walk around the vehicle]

Check item	Reference page
Illumination, flashing or for stained or damaged lights	6-100
Suspension springs damage	—
Leakage of oil, engine coolant, fuel, brake fluid, and power steering fluid	—

[5. Checking wheels and tires]

Check item	Reference page
Air pressure	6-64
Cracks and other damage	6-66
Abnormal wear	6-66
Tread depth	6-66
Disc wheel mounting condition	6-67

[6. Checks performed while driving the vehicle]

Check item	Reference page
Brake effectiveness	6-62
Driving condition at low speeds and during acceleration	6-19

Use the Specified Fuel

⚠ WARNING

- Open the fuel tank filler cap slowly. If you open it quickly, the fuel tank pressure may cause fuel to spurt out.

⚠ CAUTION

- Be sure to use extra-low-sulfur diesel fuel (containing sulfur of 10 ppm or lower).
- The use of a poor-quality diesel fuel, mixing such an additive as water remover to the fuel in the tank, or filling the tank with gasoline, kerosene or an alcohol-based fuel or its mixture with a diesel fuel will badly affect the fuel filter and result in lubrication problems in fuel-lubricated components of the injectors. In addition, this practice can also impair the operation of the engine and the diesel particulate defuser (DPD), the exhaust emission cleaning system, possibly leading to breakdown of the engine-related systems. If an incorrect fuel should accidentally be added, drain all fuel from the system. Failure to observe this precaution can result in a fire or permanent damage when the engine is started.
- The use of any fuel other than an extra-low-sulfur diesel fuel may violate the relevant regulations enforced in certain countries or regions.

**Fuel Tank Filler Cap**

→ Refer to page 3-45

Fuel

→ Refer to page 2-59

Using Self-service Filling Stations

WARNING

[Be sure to obey the following instructions when refueling the vehicle]

- Stop the engine and close the vehicle's doors and windows.
- Keep cigarettes and other flames away from the vehicle.
- Before opening the fuel tank filler cap, touch a metallic object to discharge static electricity from your body. If you have a static charge buildup on your body while refueling the vehicle, a spark caused by its discharge could ignite the fuel, resulting in burns.
- When filling, insert the nozzle deeply into the fuel filler neck. If you try to fill more fuel by pulling out the nozzle from the fuel filler neck, fuel may spill out, causing danger.
- All parts of the refueling procedure (from opening the fuel tank filler cap to completing the refueling and closing the fuel tank filler cap) must be performed by the same person.
Other people may be carrying static electricity. Do not allow them to approach the fuel filler.
The person performing the refueling procedure must not return to the seat in the cab part-way through the procedure. He/she could pick up another charge of static electricity by doing so.
- Obey all cautions posted in filling stations.
- Be sure to wipe off the fuel that is spilled at refueling.

CAUTION

[Caution when refueling the vehicle]

- Be careful not to inhale fuel vapor when refueling the vehicle.

Fuel Tank Filler Cap

→ Refer to page 3-45



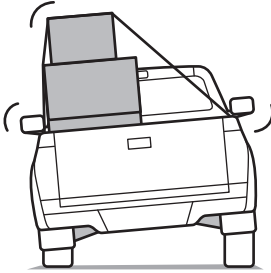

Load Cargo Correctly

**WARNING**

- Overloading can result in an accident because it places too much strain on the wheel bolts with the result that they break and the wheels come off.

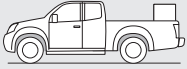
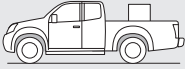
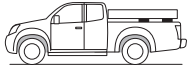
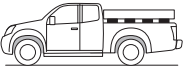
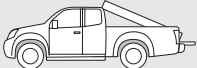
CAUTION

- The weight of the payload must be limited within the gross vehicle weight (GVW) rating and distributed over the front and rear axles so as not to exceed the axle capacities.
- It is extremely dangerous to overload the vehicle or to load the vehicle with the cargo positioned on one side. Load the vehicle correctly, observing the maximum loading capacity.
- Incorrect loading can make the cargo unstable. It can also cause an overload condition confined to a small area, resulting in damage to the cargo bed and frame.
- Overloading places undue strain on vehicle parts. It can shorten the vehicle's service life and cause an accident.

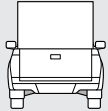
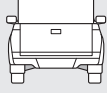
Cargo loading caution	Incorrect	Correct
Place cargo at the center of the cargo bed, not at the front or rear.		
When using supports under cargo, position them uniformly along the cargo.		
Do not allow long cargo to protrude beyond the rear edge of the cargo bed when transporting loads with a length longer than that of the vehicle bed. Rather, use supports to raise it at an angle. Avoid loading cargo using only 2 support points.		
Use ropes and tarpaulins to secure the cargo so it does not fall off the cargo bed. Use rubber bands or bungee cords to prevent the tarpaulins from flapping in the wind.		
Avoid loading cargo too high. It can cause the vehicle to tip sideways when it catches sidewinds and when turning the vehicle.		

Gross Axle Weight (GAW) and Gross Vehicle Weight (GVW) Ratings

→ Refer to page 8-7

Loading Heavy Cargo

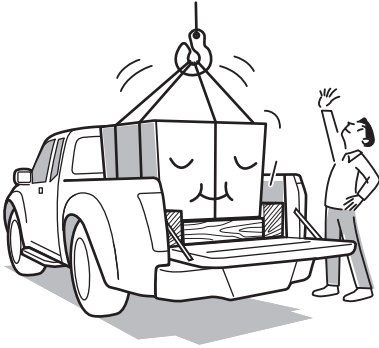
**CAUTION**

- When the cargo is heavy, take steps to prevent it from slipping and secure it with wire cables.

Do not Secure Cargo Too Tightly

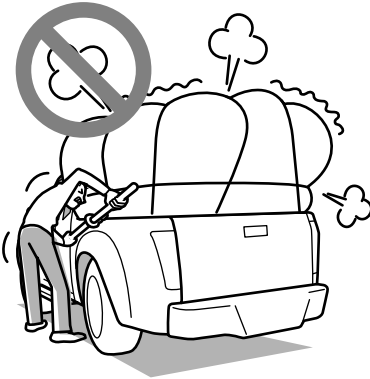
**ADVICE**

- To prevent cargo from falling off the cargo bed, it is essential to secure it with ropes and tarpaulins. However, securing it too tightly can damage the tailgate and cargo bed.

Do not Load Heavy Cargo on the Roof Rails**WARNING**

- For vehicles equipped with roof rails, adhere to the following cautionary notes and use the roof rails correctly.
 - When loading cargo on the roof rails, use the roof carrier.
 - When using the roof carrier, follow the roof carrier installation manual to properly secure cargo.
 - When loading cargo onto the roof carrier, make sure that it is firmly secured. Occasionally inspect the cargo to make sure it has not come loose during driving.
 - Do not load cargo that exceeds the total vehicle length, total vehicle width, and the total payload.
 - The roof rail maximum loading capacity is 60 kg (132.3 lb). Do not load cargo that exceeds the maximum loading capacity. If the roof carrier maximum loading capacity is less than 60 kg (132.3 lb), do not load cargo that exceeds this maximum loading capacity.
 - When cargo is loaded onto the roof rail and roof carrier, the vehicle's center of gravity will become higher, so be careful to drive the vehicle because there is a possibility that you may lose control of the vehicle and/or it may tip over during high speeds, sidewinds, acceleration, deceleration, sudden braking, cornering, lane changing, etc.

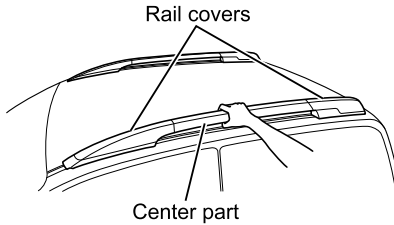
**CAUTION**

- Make sure to grab the center part of the roof rails during operations such as washing of the vehicle. If the front or rear roof rail covers are forcefully pulled, the covers may come off and cause injury to the person pulling them.
- Do not forcefully pull the roof rails up or to the sides.

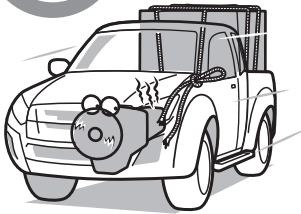
Make Sure There is No Flammable Material between the Cab and Cargo Bed**WARNING**

- Be careful not to allow the ends of ropes or the edges of tarpaulins to come lower than between the cab and cargo bed. During vehicle operation, the engine's heat could set them on fire. Carefully secure the ends of ropes and edges of tarpaulins.

Economical Driving

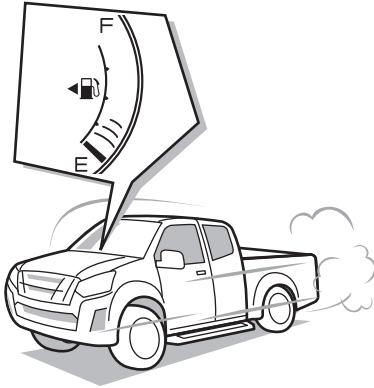

Avoid Unnecessary Engine Idling and Revving the Engine

Idling the engine for longer than necessary is a waste of fuel. The engine is sufficiently warmed up when level of the engine coolant temperature gauge is indicated. Stop the engine when waiting for people or unloading cargo, etc., even if the vehicle is only parked for a short period of time. Revving the engine will not only waste fuel, but people nearby will also be inconvenienced due to noise and exhaust gases. Do not rev the engine.

Avoid Sudden Starts and Sudden Acceleration

Sudden starting and acceleration cause the fuel consumption to increase significantly. Try to use smooth acceleration without depressing the accelerator pedal excessively.

Drive at an Economical Speed

Driving too fast causes increased fuel consumption. Be sure to drive within the legal speed limit. In addition, repeated starting and stopping, acceleration and deceleration will significantly increase fuel consumption. Aim to drive at a constant speed as much as possible.

Drive in the Appropriate Gear

Over-revving the engine when accelerating and driving at a low speed in a high gear will increase fuel consumption. Select the appropriate gear according to the traffic conditions and the load being carried.

Avoid Traffic Jams and Plan Your Journey in Advance

Driving on traffic jams will increase fuel consumption. Avoid traffic jams and plan your journey in advance as much as possible.

Unload Any Unnecessary Cargo Before Driving

The heavier the load being carried, the more that fuel consumption will increase. Unload any unnecessary cargo before driving. Mud and snow adhering to the vehicle body will also increase fuel consumption. Remove any mud or snow before driving.

Make Sure the Tire Air Pressure is Correct

Frequently inspect the tire air pressure and make sure it is always correct. Using the correct tire air pressure will help reduce fuel consumption.

Use the Air Conditioner in Moderation

Use of the air conditioner will impact fuel consumption. Try to keep the air conditioner at a suitable temperature and avoid setting the temperature too low. Also, turn the air conditioner off when it is not necessary.

Avoid Rough Roads

Driving on rough roads will lead to a greater loss of driving power transmission and increased fuel consumption.

Be Sure to Perform Proper Maintenance

Clogging up of the air cleaner element, deterioration of the engine oil and failure to adjust the engine etc. will reduce the performance of the engine and increase fuel consumption. Perform the necessary inspections, adjustments and replacements according to the Maintenance Schedule.

Unloading Cargo**CAUTION**

- When you load or unload cargo at the roadside and the cargo, cover sheet, body parts and/or other things obscure the taillights, stop lights, hazard warning flashers, turn signal lights and/or reflectors, be sure to warn other drivers and passersby by placing signs or emergency warning triangles where they are easy to see.
- When you load or unload cargo at the roadside, select a place where stopping and parking are allowed and other drivers and passersby will not be inconvenienced.

Do not Load Too Much Cargo onto the Passenger Seat and/or Rear Seat



⚠ WARNING

- Load cargo so that it is flat. Do not load cargo so that it is higher than the seatback. Sudden braking or collisions could cause the cargo to fly forward, leading to an accident that results in damage and/or injury.
- Do not place cargo onto a reclined seatback. Sudden braking could cause the cargo to fly forward, leading to an accident.

Do not Carry Fuel and Spray Cans in the Cab



⚠ WARNING

- It is extremely dangerous to carry fuel and spray cans in the cab. If such a container were to ignite or rupture, it could cause a fire or explosion.

Do not Place Objects on the Instrument Panel or Dashboard



WARNING

- Placing objects on the instrument panel or dashboard could obscure the driver's view and interfere with driving, leading to an accident. Also, vehicle acceleration or turning could cause objects to move and injure passengers.

Keep the Floor around the Driver's Seat Clean and Tidy



WARNING

- It is extremely dangerous to have empty cans, empty bottles or other items rolling around on the floor because they could get trapped under the brake pedal and prevent brake application. For proper pedal operation, it is also essential to lay floor mats properly. Incorrectly installed floor mats would hinder free movement of the pedals.
- Do not use the top of the dashboard as a place to put items that could roll, which could interfere with your driving.

Making Sure the Floor Mats Laid Out Correctly

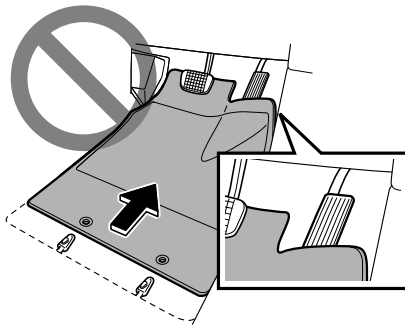

Make sure that floor mats designated for the vehicle model and model year are securely fastened on top of the floor carpet before use. When securing, make sure the clips included with the floor mats are properly installed.

WARNING

- Use the clips included with the floor mats to make sure the floor mats are kept securely fastened. Otherwise the floor mats may become misaligned and interfere with the pedals during driving, preventing accurate operation and causing a serious accident.
- Do not use floor mats that are meant for another vehicle model or model year, even if they are Isuzu genuine floor mats.
- When laying out a floor mat on the floor of the driver's seat, use the floor mat designated for the floor of the driver's seat.
- Do not use floor mats that are stacked, backwards, or flipped over.
- At regular intervals, check that the floor mats are securely fastened with the included clips. In particular, always check after the floor mats have been removed for washing of the vehicle, etc.
- Before driving and with the engine stopped, depress each pedal all the way to the floor to make sure the floor mat does not interfere with the pedals.

Choose Your Footwear Suitable for Driving

**CAUTION**

- Choose footwear that ensures proper operation of pedals when driving the vehicle. Use of footwear unsuitable for driving may cause an accident.

Sit in the Seat Correctly

**WARNING**

- Do not use the seatback as a seat when it is in a folded down position. If passengers are not sitting correctly in their seats during hard braking or a collision, it may result in fatal injuries or death.

Correct Driving Posture

WARNING

- Before driving, be sure to adjust the seat, headrest, steering wheel and mirrors to positions that give you a correct driving posture. Make sure the seat is securely retained by trying to rock it forward and backward, and put on the seat belt. All other passengers must wear seat belts.

- Seats** → Refer to page 3-48
- Headrest** → Refer to page 3-57
- Seat Belts** → Refer to page 3-61
- Mirrors** → Refer to page 3-59

Power seat model

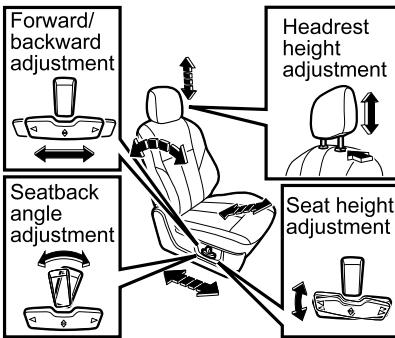

Seat Adjustment

Adjusting the seat for a correct driving posture is a fundamental part of safe driving.

Manual seat model

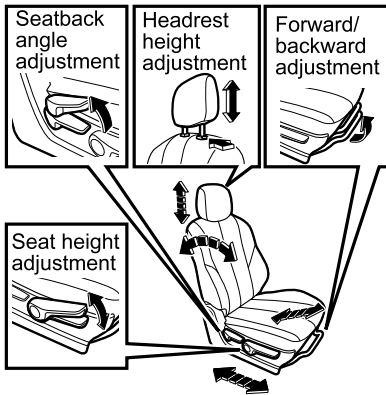

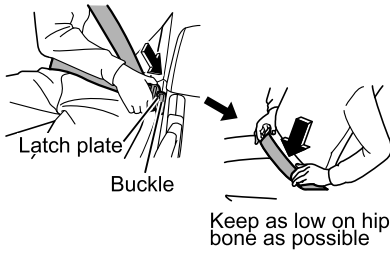

Fastening Your Seat Belt

Be sure to wear your seat belt. Sit up straight with your lower back pressed against the seat and the lap belt as low on your hip bone as possible.

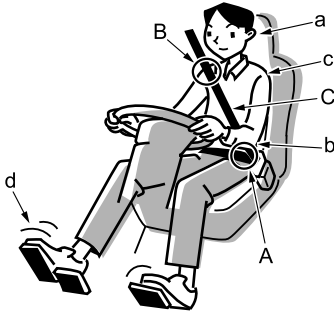

Seat adjustment recommendations	
a	Make adjustments that align the center of your head to the center of the headrest.
b	Make adjustments that allow you to easily turn the steering wheel with your elbows slightly bent.
c	Position the seatback so it is always touching your shoulders.
d	Make sure you can adequately press each pedal.

Seat belt fastening cautions		Why?
A	Position the lap belt as low on your hip bone as possible.	The pressure applied by the seat belt in a collision would be dangerous if the belt is positioned incorrectly.
B	Position the shoulder belt so it is on your shoulder (not touching your neck, chin or face).	
C	Make sure the seat belt is not twisted when you put it on.	To ensure that the seat belt is fully effective.

Passengers and Seat Belts

Only one person at a time should use each seat belt.

WARNING

- Be sure to adjust the seat before driving. Achieve the correct driving posture, gently rock the seat to make sure it is locked in place, and put on your seat belt before you start driving. All passengers must wear seat belts.
- For a child who is so small that the seat belt touches his/her face or does not rest across his/her hip bone, use an appropriate commercially available child restraint system (CRS), not the seat belt. Using the seat belt could be dangerous.

Carrying Children → Refer to page 2-21

Adjusting the Position of the Steering Wheel

You can adjust the position of the steering wheel in the up-down direction. After making an adjustment, make sure the steering wheel and lock lever are securely locked.

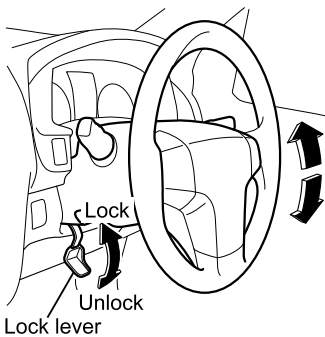

WARNING

- When you have adjusted the steering wheel, try pulling the steering wheel up and down to check that it is securely locked in position before driving.
- Adjust the position of the steering wheel before you start driving. Adjusting the position of the steering wheel while driving would be extremely dangerous because the steering wheel would rattle up and down, preventing precise steering.

Tilt Steering → Refer to page 3-58

Carrying an Expecting Mother or a Person Who is ill

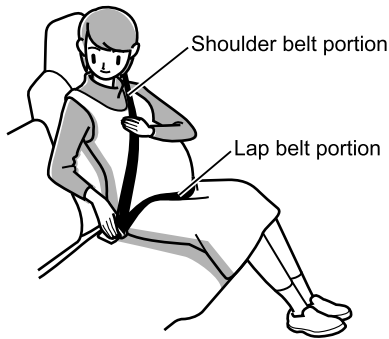
 **WARNING**

- An expecting mother or a person who is ill riding in the vehicle must also wear a seat belt. In light of the risk that the seat belt will apply pressure to the abdomen, chest and shoulders in the event of a collision, however, an expecting mother or person who is ill should get advice from a physician beforehand.
 - An expecting mother should use a three-point seat belt.
 - An expecting mother should position the lap belt snugly as low as possible on the hip bone (not across the abdomen). Also, she should fasten the shoulder belt so it rests on her chest, not on her abdomen.
 - Unless the seat belt is correctly worn, it may dig into the abdomen in the event of hard braking or a collision, harming not only the expecting mother but also the unborn child, putting them both in danger of serious injuries or death.

Seat Belts → Refer to page 3-61

Carrying Children

Using Seat Belts with Children

⚠ WARNING

- The vehicle's seat belts are designed for adults. If a seat belt touches a child's neck or chin, or does not rest across his/her hip bone, use a child restraint system (CRS) that is suitable for the child's height and weight. If the seat belt is used as it is, it could apply intense pressure to the child's abdomen in the event of a collision. A small child who is not able to sit up by him/herself must be placed in a CRS.
- Never use a rearward-facing CRS on a seat protected by an active airbag in front of it, death or serious injury to the child can occur.
- When a child is in the vehicle, securely close and lock the doors before driving.

Seat Belts → Refer to page 3-61

Child Restraint System (CRS)
→ Refer to page 3-68

Do not Leave a Child Alone in the Vehicle

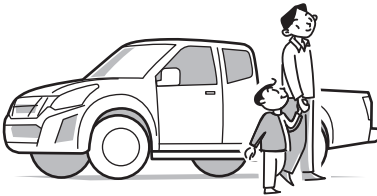

⚠ WARNING

- When you leave the vehicle, take the child with you. If you leave the child alone in the cab, the child could interfere with things, causing vehicle movement, a fire or some other accident. Also, the cab inside could become dangerously hot when heated by the sun.

Do not Allow a Child to Put His/Her Head or Hands Out of the Window**WARNING**

- Regardless of whether the vehicle is moving or stationary, you must never allow a child to put his/her head, hands, or other body parts out of the window. Allowing such behavior would be dangerous because the child could hit an obstacle.

An Adult must Open, Close and Lock the Door for a Child**WARNING**

- To protect the child from the danger of getting his/her hands and head trapped, an adult must open, close and lock the door for the child. Be careful that the child does not interfere with the power window switches and get his/her hands or head trapped in the window. While a child is in the cab, be sure to control the power windows using the power window switches beside the driver's seat.

Opening and Closing Doors

→ Refer to page 3-25

Power Windows

→ Refer to page 3-39

Driving

Proper care and operation will not only extend the service life of your vehicle but also improve oil and fuel economy.

Operation of New Vehicle

The subsequent performance and the service life of your vehicle are under the direct influence of the care and treatment that your vehicle will receive during the initial break-in period. It is therefore always recommended that during the initial 1,000 km (621 miles) break-in period, the following few simple precautions are carefully observed.

1. It is recommended that the engine speed is restricted to less than 3,000 r/min.
2. Avoid engine racing, abrupt starting and needless hard stops.
3. Always let the engine idle until it becomes thoroughly warmed up.

Check around the Vehicle before Starting the Engine

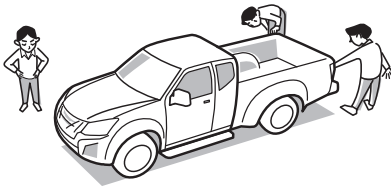

Before pulling away, perform a thorough safety check, making sure there are no children or obstructions around the vehicle.

WARNING

- Before starting the engine, make sure there is no flammable material under or around the vehicle. The presence of any such material could lead to a fire. If there is any wood within 50 cm (approximately 20 in) from the vehicle's heat source, it would represent a severe hazard as the wood could deform or discolor from the heat or it could catch fire.

Starting the Engine

→ Refer to page 4-4

Be Careful about Exhaust Emissions**WARNING**

- Exhaust emissions contain carbon monoxide, which is colorless, odorless and poisonous. If you inhale exhaust emissions, you may suffer carbon monoxide poisoning, resulting in death.
- Do not keep the engine running for any length of time in a place that is poorly ventilated. It is particularly dangerous to run the engine in a garage or other indoor place that could easily fill with exhaust gases because you could suffer carbon monoxide poisoning, resulting in death.
- Inspect the exhaust pipe from time to time. If you notice any defect (for example, a damaged joint, or a hole or crack caused by corrosion), have checks and maintenance performed by the nearest Isuzu Dealer. Continuing to use the vehicle without having the defect repaired would be dangerous because exhaust gases could get into the cab and cause carbon monoxide poisoning, resulting in death.
- If leaves, snow, etc. are on the air inlet grille of the vehicle's ventilation system, the ventilation system will not function properly. Remove any obstructions such as leaves or snow. Continuing to use the vehicle without removing obstructions would be dangerous because exhaust gases could get into the cab, resulting in carbon monoxide poisoning or death.
- If exhaust gases enter the cab through the vehicle's windows or doors when driving, carbon monoxide poisoning or death could result.
- If exhaust gases get into the cab, completely open all of the windows, and place the inside/outside air selector of the heater or air conditioner to outside air. Promptly have checks and maintenance performed by the nearest Isuzu Dealer. Continuing to use the vehicle without having the defect repaired would be dangerous because exhaust gases could get into the cab and cause carbon monoxide poisoning, resulting in death.

Starting the Engine

Manual transmission model

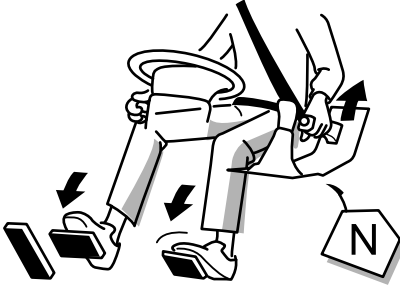

Automatic transmission model

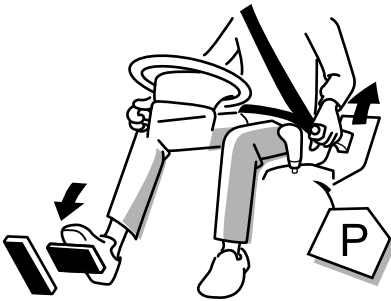

 CAUTION

- Make sure that the parking brake lever is securely pulled. On a manual transmission model, make sure the gearshift lever is in the "N" position and then hold the clutch pedal and brake pedal down fully before starting the engine. On an automatic transmission model, make sure the selector lever is in the "P" position and then hold the brake pedal down fully before starting the engine.
- Be sure to sit in the driver's seat to start the engine. If you are not sitting in the driver's seat (if, for example, you reach through the window or through the door opening), you cannot confirm the "N" position. If you start the engine of a manual transmission model with the gearshift lever in a position other than "N", the vehicle could move.

Starting the Engine

→ Refer to page 4-4

If the Vehicle Has not Been Used for a Long Period**ADVICE**

- Before using a vehicle that has not been driven for a long period, check the engine, transmission and transfer case for oil leakage, and make sure the oil is at the required levels. If there is insufficient oil, it will not adequately reach and lubricate components, and a breakdown will result.
- Start the engine and allow it to idle for at least 5 minutes. Check for abnormal noises.
- For instructions on warming up the engine, refer to "Starting the Engine" on page 4-4.

Do not Run the Engine in a Garage**WARNING**

- Running the engine in a poorly ventilated place can lead to carbon monoxide poisoning, resulting in death. Choose a well ventilated place when starting, warming-up or idling the engine.

Do not Forget to Release the Parking Brake**ADVICE**

- Pulling away with the parking brake still applied can damage the brake system.
- Before pulling away, make sure the parking brake is not set by checking that the brake system/parking brake warning light is not on.

Brake System/Parking Brake Warning Light → Refer to page 4-73

Parking Brake Lever → Refer to page 4-137

Pulling Away in a Manual Transmission Model**ADVICE**

- Pull away gently in 1st gear. Pulling away in a high gear, pulling away rapidly or slipping the clutch for a long time while pulling away can severely damage the clutch.
- When focusing on fuel economy, pulling away in 2nd gear is recommended only when the vehicle has no occupants other than the driver, is unloaded, and is on level ground.

Appropriate Gearshifts

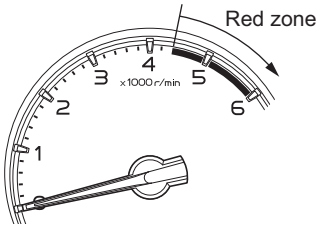
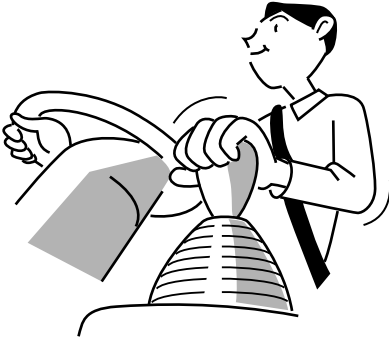

Red zone (r/min)

4,400 and above



ADVICE

- Downshifts are performed for two main purposes:
 - For engine braking on a steep and/or long downward slope
 - For responsiveness and economy on an uphill slope

[Cautions for downshifts]

- Allowing the engine to overrun can result in engine damage. Do not allow the engine to overrun when downshifting.
- Driving uphill
Downshift early to avoid heavy engine load.
- Driving downhill
In principle, you should use the same gear(s) that you used to drive up the hill. Drive at a speed that does not cause the engine to overrun (exceed its r/min limit) and the tachometer pointer to enter the red zone.

Drive at a speed that does not cause the tachometer pointer to enter the red zone.

The graduation and the red zone of tachometer are various depending on the models fitted.

Tachometer → Refer to page 4-21

Gearshift Lever → Refer to page 4-138

Selector Lever → Refer to page 4-141

Never Stop the Engine While Driving**WARNING**

- While the vehicle is being driven, do not switch the power mode to any mode other than "ON" (models with passive entry and start system) or turn the starter switch to any position other than "ON" (models without passive entry and start system). If the engine stops while the vehicle is moving, the brakes would not work properly, and the steering wheel will become extremely stiff and hard to operate. The engine could also be damaged.
- Stopping the engine while driving would be extremely dangerous because the power steering would stop working, making the steering wheel extremely hard to turn.
- Stopping the engine while driving would be extremely dangerous because the warning lights, indicator lights and other electrical circuitry would completely stop working.
- In models without passive entry and start system, placing the starter switch in the "LOCK" position while driving would be extremely dangerous because the key could come out, causing the steering wheel to lock so that it could not be turned.

Engine Start/Stop Button (Models with Passive Entry and Start System)

→ Refer to page 4-116

Starter Switch (Models without Passive Entry and Start System)

→ Refer to page 4-119

Cautions for Driving



- Concentrate on driving safely, obeying all legally designated speed limits, road signs and traffic signals.
- While the vehicle is being driven, do not switch the power mode to any mode other than "ON" (models with passive entry and start system) or turn the starter switch to any position other than "ON" (models without passive entry and start system). The power steering would stop working, making steering extremely difficult. Also, the brakes would not work well, putting you in extreme danger.
- If you notice any abnormal noise, abnormal smell or abnormal vibration from any part of the vehicle, immediately stop the vehicle in a safe place and perform checks.
- If a warning light comes on while you are driving, immediately stop the vehicle in a safe place and perform checks.
- On a manual transmission model, do not put your foot on the clutch pedal except when using the gearshift lever. Doing so would cause premature clutch wear.
- Slow down sufficiently when approaching a curve. Applying the brakes or sharply turning the steering wheel while turning the curve could cause the cargo to shift, the tires to slip and the vehicle to tip onto its side.
- While driving, do not place your hand on the gearshift lever/selector lever except when changing gears. Doing so could cause the transmission to fail.

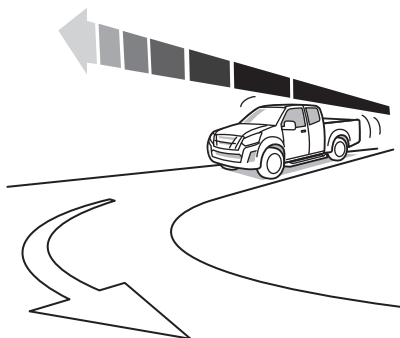

- Avoid scraping the tire sidewalls against curbstones or driving over dips and protrusions in the road surface. You could damage the wheels or tires, resulting in a blowout or flat tire.
- When going down on a steep slope, avoid driving the vehicle backward as much as possible. Drive it forward slowly on the down slope.
- Compared with forward movement, the braking distance of backward movement is longer, and the steering response of that is worse.
- If you must drive the vehicle backward, drive it very carefully and gradually by moving and stopping repeatedly in order to stop it any time.
- The brakes give strong braking force with only light pressure on the pedal. Do not press the brake pedal hard except in the event of an emergency.
- Nighttime driving is more dangerous than daytime driving because the field of view is narrower. Keep your speed down, and maintain an ample headway distance.
- When driving in fog, turn on the front fog lights (if equipped), rear fog light (if equipped) and drive slowly, using the road's center line as a guide. It is dangerous only to follow the lights of the preceding vehicle because they can cause optical illusions. Drive with caution.
- Speeds on highways are higher than those on regular roads, so there is more danger. Also, a breakdown on a highway represents a hazard to other vehicles and can cause an accident. Concentrate on safe driving. Remember to perform daily pre-operation inspections and use highway driving techniques.
- Your sense of how fast you are traveling becomes distorted on long highway drives. Constantly keep an eye on the speedometer, and maintain a suitable headway distance.
- During high-speed driving, even a little turn of the steering wheel causes a big movement of the vehicle. Turn the steering wheel slowly.

Driving Down a Long Slope

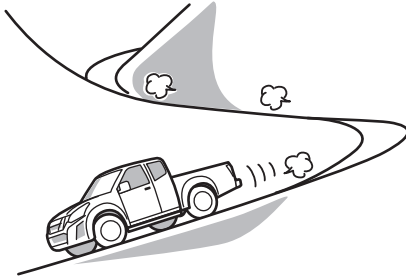

When driving down a long slope, use engine brake together with the foot brakes. Using the low-gear engine brake reduces the work load on the foot brakes and yields greater braking force. In automatic transmission models, do not use the auto mode, as it does not provide engine efficiency. Use only the manual mode for engine braking.



CAUTION

- Frequent use of the foot brakes can cause vapor lock and brake fade, resulting in reduced brake effectiveness.
- Be very careful when using engine braking in a low gear because the engine is likely to over-rev.



NOTE

[What is vapor lock?]

- If the brakes overheat due to frequent use, the heat can cause the brake fluid to boil so that air bubbles are created in the brake fluid. Pressing the brake pedal simply compresses the air bubbles; pressure is not transmitted to the wheel cylinders, so the brakes' effectiveness sharply deteriorates. This phenomenon is called vapor lock.

[What is brake fade?]

- Frequent use of the brakes can cause the brakes to overheat so that the frictional force of the friction surface decreases and the brakes become less effective than normal. This phenomenon is called brake fade.

Driving in Bad Weather (Rain, Icy Roads, Snowy Roads, etc.)



CAUTION

- In bad weather, visibility is reduced and slippery road surfaces increase stopping distances. Drive more slowly than you would in good weather. Also, avoid sharp turns of the steering wheel and hard braking. Use engine brakes together with the foot brakes to decelerate.



ADVICE

- There is a risk of hydroplaning, particularly where water tends to collect on the road surface. Drive at speeds that allow you to stay in complete control.
- If you cannot avoid driving on a flooded road, first check the depth of the water and then drive through the water at a slow, constant speed. There is a risk that water will get into the engine's cylinders and cause engine damage (water hammering). Keep your speed down, and drive with great care.



NOTE

[What is hydroplaning?]

- If a vehicle is driven at high speed on a road that is covered with water, a layer of water can form between the tires and road surface, causing the tires to lose their grip and slide across the water. This phenomenon is called hydroplaning. It is dangerous because it makes the steering wheel and brakes useless.

Driving on Snowy or Icy Roads

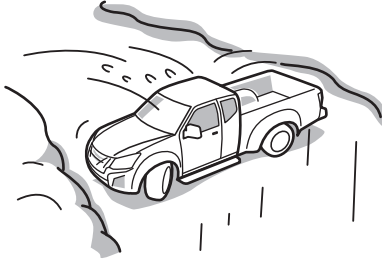

Caution on Slippery Roads

**CAUTION**

- On slippery roads, never accelerate rapidly, brake hard, decelerate rapidly or make sharp turns of the steering wheel.
- There is a risk of reduced grip between the tires and road surface and of increased braking distances. The danger of icy road surfaces is particularly great on bridges, in shady places and where there are puddles. Keep your speed down and be sure to use tire chains or winter tires on snowy or icy road surfaces.
- Use lower gears to overcome the retardation effect of the engine. Apply the foot brakes lightly.

**NOTE**

- On a snowy or icy road with an automatic transmission model, by depressing the brake pedal you can make a standing start in the manual mode 2nd gear and move the selector lever to the "+" (upshift) position.
- When you want to free the vehicle from snow where the tires may slip slightly by increasing the engine speed, you can press the ESC OFF switch to disable just the traction control system (TCS).

Using Tire Chains → Refer to page 2-72
Model with Automatic Transmission

→ Refer to page 4-143

Electronic Stability Control (ESC)

→ Refer to page 4-163



Pay Attention to the Way the Steering Wheel Turns and Feels

CAUTION

- On snowy roads, water and snow splashed up by the tires can freeze and accumulate inside the fenders, making the steering wheel hard to turn. From time to time, get out of the vehicle and remove any accumulated snow. Do not use a sharp implement to remove the snow. Sharp edges could damage rubber parts.

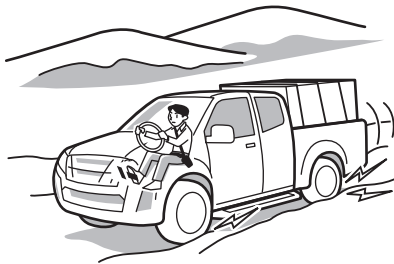

Check the Brakes from Time to Time

CAUTION

- When the vehicle is driven or parked on a snowy surface, ice can form on the brakes, decreasing their effectiveness. From time to time while you are driving, press the brake pedal lightly and check the brake's effectiveness. Pay attention to vehicles both ahead and behind you when checking the brakes in this way.
- Also, check the brake's effectiveness as soon as possible when starting to drive the vehicle after it has been parked. If the brakes do not work well, drive slowly and gently press the brake pedal several times until the brakes dry out and start working normally.

Removing Snow from the Underbody

Look under the vehicle and remove any lumps of ice that are stuck to the underbody. Be careful not to damage components.



ADVICE

- Do not use a sharp implement to remove snow. Sharp edges could damage rubber parts.

Driving on Poor Road Surfaces (Sand or Mud)

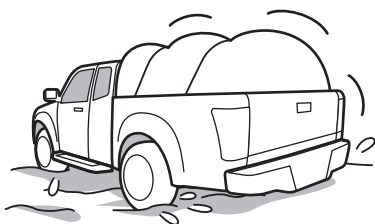

When you cannot avoid driving through deep mud, using tire chains is an effective way to avoid getting stuck.



ADVICE

- When driving in sand or mud, avoid hard braking, sudden acceleration and sharp turns of the steering wheel. Such actions could get the vehicle stuck and make it impossible to extricate.
- After driving through deep mud, any mud stuck to the vehicle can harm the steering, brakes and powertrain. Wash the vehicle and remove all mud and other incrustation.
- In models with automatic transmission, shift the transmission to the "2" or "1" position to avoid overheating the transmission when towing or when driving slowly in mud, sand, on snowy roads or steep inclines.
- The vehicle speed sensors are fitted on the wheels. When removing mud and other incrustation, take great care not to damage the components.
- Do not use a sharp implement to remove mud. Sharp edges could damage rubber parts.

**NOTE**

- On a muddy road with an automatic transmission model, by depressing the brake pedal you can make a standing start in the manual mode 2nd gear and move the selector lever to the "+" (upshift) position. This provides better traction and safer vehicle operation.
- When you want to free the vehicle from mud where the tires may slip slightly by increasing the engine speed, you can press the ESC OFF switch to disable just the traction control system (TCS).

Exterior Maintenance

→ Refer to page 6-114

Selector Lever → Refer to page 4-141**Anti-lock Brake System (ABS)**

→ Refer to page 4-158

Electronic Stability Control (ESC)

→ Refer to page 4-163

When Driving on Bad Roads

→ Refer to page 7-56

When the Vehicle Has Been Driven on a Flooded Road or Washed

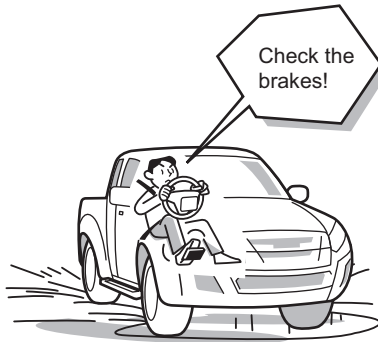

CAUTION

- If the vehicle must be driven on a flooded road, is washed, or is parked in an area that becomes flooded, water can get into the brakes and reduce their effectiveness. If the brakes do not work well afterward, drive slowly and gently press the brake pedal several times until the brakes dry out and start working normally.



ADVICE

- If the vehicle must be driven on a flooded road or is parked in an area that becomes flooded, promptly have your Isuzu Dealer perform a check for the following points:
 - Effectiveness of the brakes
 - Water-ingress, or damage to drum brakes or disc brakes
 - Engine damage due to water-ingress
 - Shorting of electrical components
 - Oil level and degradation (cloudiness) of the engine, transmission, differential and transfer case
 - Greasing of each components (lubrication)

Sidewinds



ADVICE

- If the vehicle catches a sidewind and drifts sideways, firmly grip the steering wheel, decelerate to a speed that allows you to stay completely in control and make a directional correction. The vehicle may catch strong sidewinds in the following situations:
 - Emerging from a tunnel; Driving over a bridge, driving on an embankment or driving through a cutting
 - Being overtaken by a large truck or bus
 - Overtaking a large truck or bus

Dealing with a Blowout or Flat Tire while Driving

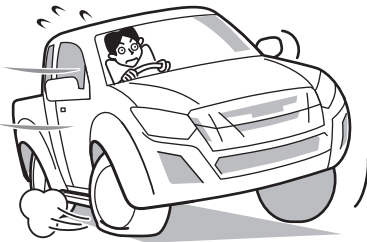

WARNING

- If you feel any abnormality in a tire while driving, immediately stop in a safe place. If you continue to drive on a flat tire, undue force would be applied to the wheel bolts, possibly causing the bolts to break and the wheel to come off.



ADVICE

- If a blowout or flat tire occurs while you are driving, calmly grip the steering wheel and gradually apply the brakes to decelerate. (Hard braking would be dangerous because it could cause the steering wheel to be pulled to one side.) Stop the vehicle in a safe place, and change the tire if the vehicle is the model equipped with the spare tire, or repair the tire if the vehicle is the model equipped with the emergency flat tire repair kit.

Tools → Refer to page 6-7

Spare Tire → Refer to page 6-70

How to Use the Emergency Flat Tire Repair Kit (4WD Crew Cab Models for the Singapore Market)

→ Refer to page 7-14

Handling the Jack → Refer to page 6-74

Changing Tires → Refer to page 6-79

If the Underside of the Vehicle Receives a Hard Bump**ADVICE**

- If the underside of the vehicle receives a hard bump, stop in a safe place where the vehicle will not obstruct traffic and check for brake fluid leakage, fuel leakage and component damage. If any part of the vehicle is damaged or broken, promptly have the vehicle inspected and repaired by the nearest Isuzu Dealer.

If a Warning Light Comes On or Flashes**ADVICE**

- If a warning light comes on or flashes, do not ignore it, and do not keep driving. Be sure to take corrective action referring to the explanation of the meters and warning lights.

**How to Read the Instruments
(Instruments Layout)**

→ Refer to page 4-16

Warning and Indicator Lights Layout

→ Refer to page 4-26

Off-road Driving



During off-road driving, carefully confirm the road condition, incline and other factors, and drive at a reduced speed.

WARNING

- When driving off-road or on extremely uneven road surfaces, drive at a reduced speed. Avoid making jumps, making sharp turns, and striking objects with the vehicle. Failure to observe these cautions may result in loss of control or overturning of the vehicle. In addition, damage to the vehicle may also result.
- Do not place your hands in the steering wheel spokes when driving off-road. If the vehicle's wheels suddenly change direction, the steering wheel may turn, resulting in injury to your hands. Do not place your thumbs inside the rim when gripping the steering wheel.
- On inclined surfaces, drive straight, at right angles to the incline. Driving parallel to the incline (as with other, similar vehicles) may result in overturning of the vehicle.
- After driving in mud, sand or flooded roads, be sure to confirm that the brakes function correctly.

Automatic Transmission Model



On an automatic transmission model, there is no need to use a clutch pedal; you can pull away, change gears and stop the vehicle by only using the selector lever, accelerator pedal, and brake pedal. Be sure to learn the characteristics of the automatic transmission model and how to correctly operate it. When the vehicle is stationary, remember to keep the brake pedal firmly pressed and, if necessary, place the selector lever in "P" or "N" position and apply the parking brake.

Immediately after engine startup, while the air conditioner is running in models with the air conditioning system, the engine speed automatically rises. As this makes creep stronger than it is at other times, be sure to keep the brake pedal firmly pressed.

Model with Automatic Transmission

→ Refer to page 4-143



NOTE

[Creep]

- With the engine running and the selector lever in a position other than "P" or "N" selected, power reaches the wheels even when the accelerator pedal is not pressed, causing the vehicle to tend to move. This phenomenon is called creep. The higher the engine speed, the stronger the creep and the greater the vehicle's tendency to move.

Operate the Brakes with Your Right Foot



ADVICE

- Sit in the correct driving position, and use your right foot to operate the brake and accelerator pedals. To avoid accidentally pressing the wrong pedal, check the pedal positions and practice putting your foot on the desired pedal.
- To ensure reliable brake application, be sure to use your right foot to press the brake pedal.

Pulling Away

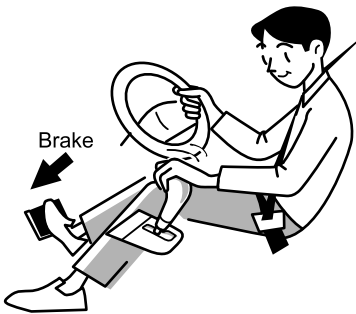

1. Sitting in the correct driving position, firmly depress the brake pedal with your right foot and place the selector lever in the "D" position (auto mode or manual mode) for forward movement or the "R" position for backward movement.
2. Check to be sure that the area around the vehicle is clear and check the selector lever position and shift indicator, and then release the parking brake lever.
3. Take your foot off the brake pedal, then gradually press the accelerator pedal to pull away.

**WARNING**

- When you move the selector lever to a position other than "P" or "N", creep will cause the vehicle to move. When pulling away, be sure to keep the brake pedal pressed as you operate the selector lever.
- When pulling away, be sure to visually check the selector lever position and the shift indicator for safety reasons. If you always operate the selector lever while pressing the push button, it is possible to accidentally shift the lever to the "P" or "R" position in some cases. Get in the habit of shifting the selector lever from the "N" to "D" or "D" to "N" position without pressing the push button.
- Do not operate the selector lever while pressing the accelerator pedal. Doing so is dangerous because the vehicle will suddenly move.
- Immediately after engine startup, while the air conditioner is running in models with an air conditioning system, the engine speed automatically rises, making creep stronger than it is at other times. Keep the brake pedal firmly pressed.

**ADVICE**

[Essential points for safety]

- Even if you plan to drive only a short distance, adopt the correct driving position and make sure you can firmly press the brake and accelerator pedals.
- When backing up the vehicle, you twist to look rearward so pedal operation becomes difficult. Firmly press the brake pedal while twisting your body. Also, get in the habit of immediately returning the selector lever to the "N" position after backing up. When pulling away, visually check the selector lever position and the shift indicator.
- When repeatedly shifting the selector lever between forward and reverse gears for a multiple point turn or a K-turn, firmly press the brake pedal and confirm that the vehicle is completely stopped before shifting the selector lever.

**NOTE**

- After the vehicle has been left for a week or more it may not start at once, even when the accelerator pedal is pressed. In such cases, shift the selector lever to the "P" position and wait for several seconds with the engine idling.

Model with Automatic Transmission

→ Refer to page 4-143

Actions that Can Lead to a Breakdown with an Automatic Transmission Vehicle

Action that can lead to a breakdown	Breakdown symptom
<ul style="list-style-type: none"> • Stopping the vehicle on an uphill road with the selector lever in a position other than "P" or "N", with the engine gunned, and the brakes not applied. • Pressing the accelerator pedal and brake pedal at the same time. 	<ul style="list-style-type: none"> • Automatic transmission fluid overheats.
<ul style="list-style-type: none"> • Operating the selector lever with the engine gunned and the engine speed high. 	<ul style="list-style-type: none"> • The automatic transmission gears or clutch are overloaded.
<ul style="list-style-type: none"> • Operating the selector lever to the "P" position before the wheels are completely stopped. 	<ul style="list-style-type: none"> • The parking mechanism is damaged.
<ul style="list-style-type: none"> • Switching the power mode to "ACC" (models with passive entry and start system) or turning the starter switch to the "ACC" or "LOCK" positions (models without passive entry and start system) while the vehicle is being driven. • Keeping the selector lever in the "N" position on a long downward slope. (This is dangerous due to the lack of engine brake.) 	<ul style="list-style-type: none"> • The automatic transmission is not properly lubricated.

Four Wheel Drive (4WD) Model

Four-wheel drive does not make it possible to drive a vehicle absolutely everywhere. Exercise caution when using the accelerator pedal, steering wheel and brake pedal. Concentrate on driving safely, paying attention to the condition and slope angle of the road surface.

Four Wheel Drive (4WD) Model

→ Refer to page 4-176

Driving on Snow-covered or Icy Roads

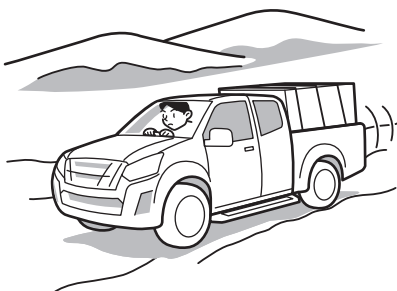

On a snow-covered or icy road, drive at a constant speed and keep your speed low enough to stay completely in control.

When applying the brakes, lightly push the pedal several times rather than giving it one hard push. A single hard push of the pedal would be dangerous because it could cause the vehicle to slip, making the steering wheel useless.



ADVICE

- Use tire chains and winter tires on snow-covered or icy roads.

Winter Tires → Refer to page 2-60

Using Tire Chains → Refer to page 2-72

Driving in Sand or Mud

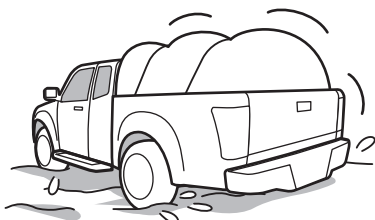

When driving in sand or mud, go as slowly as possible, avoiding hard braking, sudden acceleration and sharp turns of the steering wheel.

It is difficult to ascertain the condition of the road surface when you are driving on sand or mud, so there is a risk of getting stuck. When necessary, get out of the vehicle and check the condition of the road surface.

Driving through Water

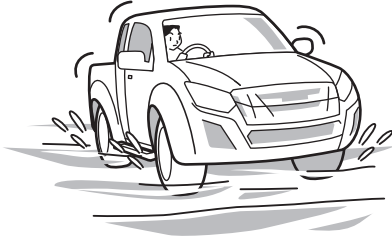

The vehicle is not completely impervious to water. Avoid driving through water.



ADVICE





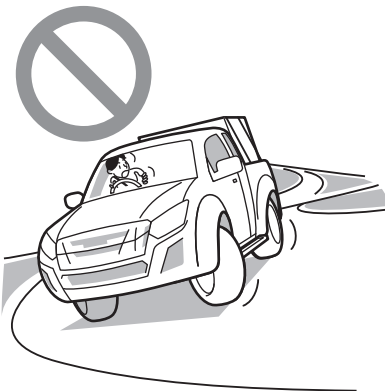

- If you cannot avoid driving through water, first check the depth of the water and then drive through the water at a slow, constant speed. There is a risk that water will get into the engine's cylinders and cause engine damage (water hammering).
- If the vehicle must be driven through water, promptly have your Isuzu Dealer perform a check for the following points:
 - Effectiveness of the brakes
 - Water-ingress, or damage to drum brakes or disc brakes
 - Engine damage due to water-ingress
 - Shorting of electrical components
 - Oil level and degradation (cloudiness) of the engine, transmission, differential and transfer case
 - Greasing of each components (lubrication)

U-turn on Sharp Slopes

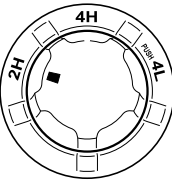
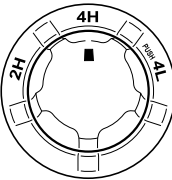
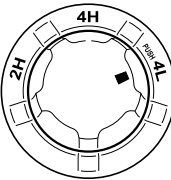

When making a U-turn on a sharp slope, the vehicle is in danger of turning over the moment it crosses the slope. Drive carefully selecting the road surfaces so that the tires on the higher side of the slope may not run on any convex part of the slope surface.

Guidelines for Switching between 2WD (Rear-Wheel Drive) and 4WD (Four-Wheel Drive)

Drive type	2WD		4WD	
	2H	4H (4WD high)	4L (4WD low)	
4WD switch				
Indicator light	OFF			
Models with MID*				
Driving conditions	During normal driving on an ordinary road or highway.	Wet roads, snow-covered roads, icy roads, and other roads where the vehicle needs more traction than 2WD.	Steep slopes, rough roads, sand, mud or deep snow, and other roads where the vehicle needs significant traction.	

*: When the 4WD switch has been operated in each position, it will be displayed on the MID for approximately 3 seconds.



ADVICE

- Do not set the 4WD switch midway between the "2H" and "4H" positions or the "4H" and "4L" positions. Doing so could cause a malfunction.

Stopping and Parking

Parking



ADVICE

- Choose a flat place where stopping and parking are permitted and where the vehicle will not obstruct traffic. Firmly apply the parking brake and make sure the vehicle does not move.
- Avoid parking for long periods with cargo on the vehicle.
- Remove all dirt from the vehicle's light lenses and reflectors to ensure that the vehicle can be seen from other vehicles.

Applying the Parking Brake



ADVICE

- Except in an emergency, do not apply the parking brake until the vehicle has come to a complete stop. Applying the parking brake before the vehicle has stopped can cause a breakdown.

Parking Brake Lever

→ Refer to page 4-137

Parking Safely on a Slope

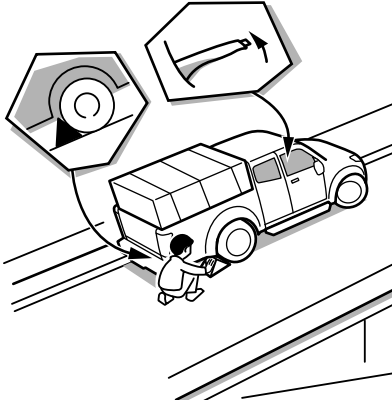
**CAUTION**

- Avoid parking your vehicle on a slope as much as possible and choose a level and flat place. If it is unavoidable to park your vehicle on a slope, be sure to set the parking brake fully, make sure that the vehicle does not move, and block the wheels with chocks for added safety. For a manual transmission model, also leave the vehicle in gear to further ensure that it will not move.
- Leave the steering wheel turned such that the vehicle will be stopped by an obstruction (for example, the curb) in the unlikely event that it moves.

Parking in Cold Regions



When snow collects around the wheels and lights, try to remove it before night falls.

Do not apply the parking brake in cold regions. If you leave the parking brake applied, the wires and brake shoes could freeze up, making it impossible for you to release the parking brake. Be sure to park the vehicle in gear.

For manual transmission models, be sure to park the vehicle by shifting the gearshift lever into the "1 (1st gear)" or "R (reverse)" position when in a flat location. For automatic transmission models, shift the selector lever into the "P" position, check whether "P" is indicated on the shift indicator, park the vehicle in a flat location and then stop the engine.

Be sure to put chocks against the tires.



CAUTION

- If you park in a place where there is a lot of snowfall, snow accumulating around the vehicle could limit ventilation. Running the engine with the vehicle in these conditions could cause exhaust gases to enter the cabin, resulting in carbon-monoxide poisoning. Take preventive action by, for example, clearing the snow around the vehicle.

Napping in the Vehicle

 **WARNING**

- Before taking a nap in the vehicle, be sure to stop the engine and switch the power mode to "OFF" (models with passive entry and start system) or turn the starter switch to the "LOCK" position (models without passive entry and start system). Otherwise, any unintended contact with the gearshift lever/selector lever or accelerator pedal while you are asleep could cause the vehicle to move, resulting in an accident.
 - If you leave the engine running and unintentionally keep the accelerator pedal pressed while asleep, the engine, diesel particulate defuser (DPD), muffler, and exhaust pipe could become abnormally hot, resulting in a fire.
 - If you leave the engine running while taking a nap with the vehicle parked in a place where exhaust gases could get into the cab (for example, a place that is poorly ventilated), you could suffer carbon monoxide poisoning, resulting in death.

Keep Flammable Material Away from the Vehicle

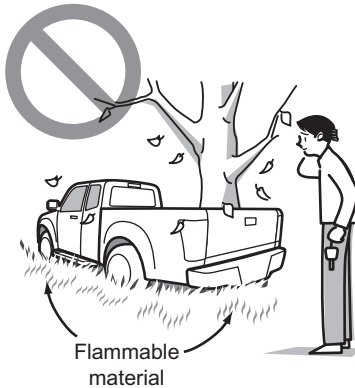

WARNING

- After driving through tall grass, mud, rocks, sand, water, etc., check that there is no grass, branches, paper, rags, stones, sand, etc., adhering to or trapped under the vehicle body. If the vehicle is operated with these materials trapped or adhering to the underbody, a failure or fire could occur. Clear off any such matter from the underbody.
- The diesel particulate defuser (DPD), muffler, and exhaust pipe are extremely hot while the engine is idling, or immediately after vehicle operation. In order to prevent fires, make sure the surrounding area is free of flammable material (for example, grass, waste paper, oil or old tires). Take particular care when parking in a garage.
- Use caution concerning hot exhaust gases while the engine is idling, or immediately after the engine has been stopped. Otherwise, you could be burned.

Stopping and Parking with the Engine Running

WARNING

- When stopping and parking with the engine running: If your vehicle is the manual transmission model, be sure to place the gearshift lever in the "N" position. If your vehicle is the automatic transmission model, be sure to place the selector lever in the "P" position and check that "P" is indicated in the shift indicator. Then, firmly apply the parking brake. Unless you take these steps, any unintended pressure on the accelerator pedal could cause an accident.

Do not Touch the Gearshift Lever/Selector Lever while the Vehicle is Stationary with the Engine Idling

WARNING

- Do not touch the gearshift lever/selector lever while the vehicle is stationary with the engine idling. If you touch the gearshift lever/selector lever at this time, a gear could be selected and the vehicle could move even with the parking brake applied. The risk of knocking against the gearshift lever/selector lever and causing an accident is particularly great when you move in or out of your seat.

Be Sure to Have the Engine Running when the Vehicle is Moving

CAUTION

- When the engine is not running, the power steering system does not work so the steering wheel is hard to turn. Also, the brake booster does not work so there is little braking ability. If you coast down a slope without the engine running, you would not be able to properly control the vehicle and could have an accident.

Look Around before Opening a Door

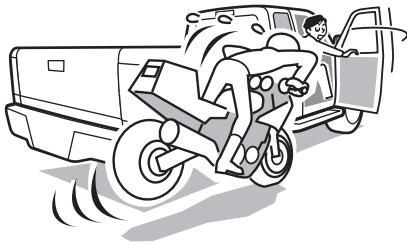

CAUTION

- Before opening a door, check the area around the vehicle by looking forward, rearward and to the sides. If you suddenly open a door without checking the surrounding area, the door could be hit by a vehicle behind you or a pedestrian.

Leaving the Vehicle

 **WARNING**

- When leaving the vehicle, be sure to apply the parking brake, stop the engine and lock the doors. Do not leave valuables where they can be seen from outside the vehicle.
- If you are traveling with a child, do not leave the child alone in the vehicle. If the child touches the controls or equipment, an accident could occur. (For example, the vehicle could move or a fire could start.) Also, the cab inside could become dangerously hot in hot weather.
- Do not leave eyeglasses or a lighter in the vehicle. If the cab inside becomes hot, a lighter left there could explode and plastic eyeglass lenses or frames could deform or crack.
- Do not leave your vehicle unattended with the engine running. If the engine should overheat, you would not be there to react to the engine overheat warning light, engine overheat warning buzzer, or engine coolant temperature gauge. This could result in costly damage to your vehicle and its contents.

Starting to Drive When the Vehicle Has Been Parked

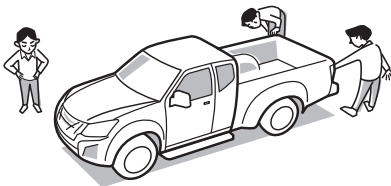

Before pulling away, perform a thorough safety check, making sure there are no children or obstructions around the vehicle.

Reversing

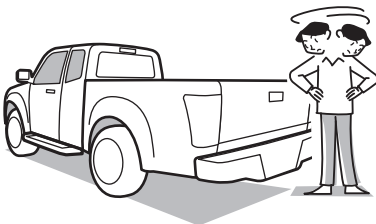

If you cannot see the area behind your vehicle well enough to confirm it is safe to back up, get out of the vehicle and check behind it.

Pulling Away after a Temporary Stop

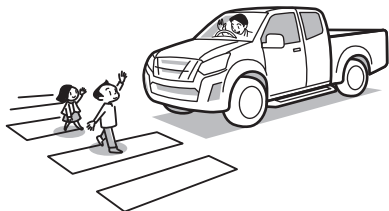
**CAUTION**

- Make it a habit to look around and confirm that it is safe to pull away after a temporary stop (at traffic lights, for example).

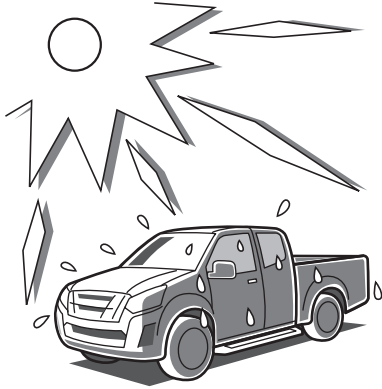
Cautions for Driving in Hot Regions

The engine will be prone to overheating in an environment where the ambient temperature is high. To prevent the engine from overheating, pay attention to the following points:

**CAUTION**

- Do not put well water, river water or other hard water in the engine cooling system. It would hasten the formation of rust and scale.

If foreign matter (insects, mud, etc.) gets stuck in the radiator's air passages, the cooling system's performance will deteriorate. Check the air passages for clogging, and remove any foreign matter using tap water.

Handling the Radiator and Intercooler

→ Refer to page 6-45

**ADVICE**

- When the ambient temperature is high, evaporation of battery fluid will become quicker. Frequently check the battery fluid level and, when necessary, add more fluid.

Checking the Battery Fluid Level

→ Refer to page 6-110

Cautions for Driving in Cold Regions



The following cautions apply to snowbound regions and to mountainous regions, ski resorts and other areas of extreme cold and/or snowfall. Please use them also for reference in winter in other regions.

For the sake of your vehicle, have your Isuzu Dealer make the winter preparations described hereafter. Also have these preparations made before driving to a cold region.

Engine Coolant → Refer to page 6-40

Windshield Washer Fluid

→ Refer to page 6-96

Handling the Battery

→ Refer to page 6-101

Engine Oil → Refer to page 6-20

Using Tire Chains → Refer to page 2-72

Winter Tires → Refer to page 2-60

WARNING

- Snow or obstructions surrounding the vehicle could limit ventilation. Running the engine with the vehicle in such a situation could cause exhaust gases to enter the cab, resulting in carbon monoxide poisoning or death. Take preventive action, for example, by clearing any snow or obstructions around the vehicle.

CAUTION

- Do not cover the front of the radiator with newspapers, cardboard or any other flammable material to raise the engine coolant temperature.
- If you allow the engine to warm up but the engine coolant temperature does not rise, have the nearest Isuzu Dealer inspect the thermostat.

Fuel → Refer to page 2-59

Protection of Engine against Overcooling

Overcooling of the engine not only accelerates wear of the vital engine parts but also deteriorates fuel economy.

Engine Coolant



To prevent the engine damage due to freezing of the engine coolant and to protect the cooling system from corrosion, mix the coolant and water to be an appropriate concentration.

Replace damaged rubber hoses as the engine coolant becomes liable to leak even past minor cracks when the engine coolant solution is used.

Preparing Engine Coolant

→ Refer to page 6-41

Engine Oil

The engine oil tends to harden with lowering temperatures. Use engine oil with a viscosity suited to ambient temperature.

Recommended Fluids, Lubricants and Diesel Fuels → Refer to page 6-130

Engine Oil and Gear Oil Viscosity Charts → Refer to page 6-134

Fuel

If you drive to a cold region in winter while using diesel fuel for warmer regions that freezes at a relatively high temperature, the fuel may freeze. As the ambient temperature decreases, the fuel in the fuel tank and pipes may freeze like slush, making the engine hard to start.



NOTE

- The specifications of diesel fuel differ according to the season and region.

When Ice Prevents You from Putting the Key in the Door or Opening the Door



If you try to force the key into the door, you could bend it. And if you try to pull the door open with undue force, the rubber seal around the door could come unstuck or become damaged. Use warm water to melt the ice, then quickly wipe it away and open the door.

If the wipers, electric door mirrors, or power windows freeze up, also use warm water to melt the ice and then operate the system. Otherwise, you could damage the mechanism and drain the battery. After that, wipe the water away.

Winter Tires

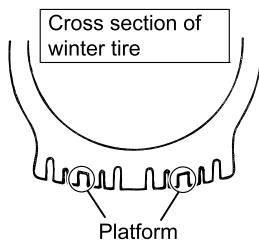

Use winter tires of the same sizes as the standard tires. Also, use wheels of the same size as those with the standard tires.

A winter tire has reached its wear limit when the tread grooves have worn to half of the depth of the new tire. At this time, platforms indicating that the tire can no longer give adequate performance on snow become visible in the grooves. Replace the tire with a new one.



CAUTION

- Avoid sharp turns of the steering wheel and hard braking. Use the engine brake to decelerate. When applying the brakes on snowy or icy road, lightly press the pedal several times rather than giving it one hard press. A single hard press of the pedal would be dangerous because it could cause the vehicle to slip or skid.
- Avoid driving at high speeds on a dry road with winter tires.
- Comply with local legal requirements when using winter tires.

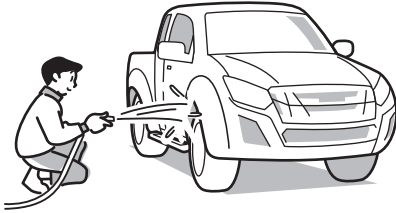
Cleaning the Vehicle after Driving on Snowy Roads**CAUTION**

- Remove snow that has stuck to the inside of the fenders and to the brake hoses. Otherwise, it may damage components. After driving on a salted road, wash the underside of the vehicle as soon as possible to prevent the salt from causing rust. Spraying water under high pressure is an effective way to get the salt off.
- After washing the vehicle, wipe the door openings dry.

**ADVICE**

- The vehicle speed sensors are fitted on the wheels. When removing snow, ice and other incrustation, take great care not to damage the components.
- Do not use a sharp implement to remove snow. Sharp edges could damage rubber parts.

Anti-lock Brake System (ABS)

→ Refer to page 4-158

Staying Safe

When the Engine Coolant is Hot



WARNING

- Do not loosen or remove the radiator cap while the engine coolant is hot. Doing so would be dangerous because steam and hot air would shoot out.

When the Engine Overheats

→ Refer to page 7-32

When the Muffler and Exhaust Pipe are Hot

CAUTION

- The diesel particulate defuser (DPD), muffler, and exhaust pipe are extremely hot while the engine is running, during DPD regeneration, and immediately after vehicle operation. Be careful not to inadvertently touch them. Otherwise, you could be burned.

Do not Allow Your Hands to Become Trapped in the Side Access Panel (Extended Cab Model)



WARNING

- When riding in the cargo bed, do not place your hands near the side access panels since there is a risk of injury when the side access panels close.

After Using the Ashtray



WARNING

- Be sure to close the ashtray lid after using the ashtray. Otherwise, any unextinguished cigarette butt could set fire to other cigarette butts, resulting in a fire.
- Do not allow the ashtray to become overly full of cigarette butts. Also, do not put flammable material in the ashtray.
- Never throw lit cigarette butts out the window. They not only litter the road and around but also can cause a roadside fire.

Ashtray → Refer to page 5-37

Do not Attach Accessories to the Windshield or Windows

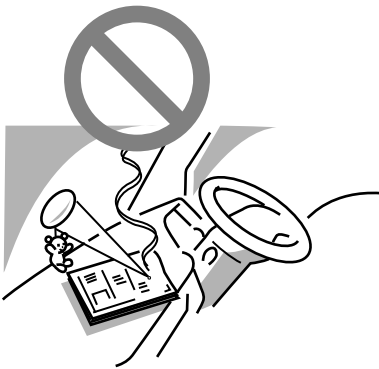

WARNING

- Do not attach ornaments, films or other accessories to the windshield or windows. They would impair visibility. Also, any plastic suction cups used to attach accessories could cause a fire or other accident by acting as lenses.

Do not Use a Mobile Telephone while Driving



CAUTION

- Drivers should never use mobile telephones or car phones in any mode other than hands free while driving. Doing so is dangerous.
- Using a mobile telephone while driving could result in an accident because you would not be paying full attention to your surroundings.
- If you are driving and you wish to use a mobile telephone, first stop the vehicle in a safe place.

Using the Jack

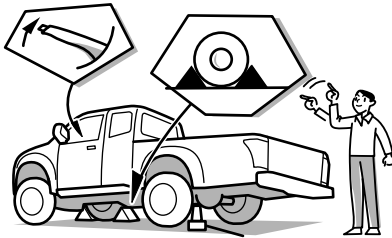

WARNING

- Jacking up a vehicle on slope or soft ground is extremely dangerous. Be sure to jack up the vehicle on a firm, level surface.
- Set the jack in the correct position. Do not forget to first apply the parking brake and place chocks around the wheels.
- When a rear wheel is jacked up, the parking brake has no effect. Failing to first put chocks in the correct places would be dangerous because the vehicle could move.
- It might start moving when the engine power is transmitted to the rear axle even when one of the wheels on the axle is raised clear of the ground. Do not start the engine with any rear wheel in contact with the ground.

WARNING (Continued)



WARNING (Continued)

- Do not get under a vehicle and no person should place any portion of their body under a vehicle that supported by a jack. Failure to observe this precaution could lead to an accident if the jack were to slip.

Tools → Refer to page 6-7
Handling the Jack → Refer to page 6-74

If the Battery Goes Flat

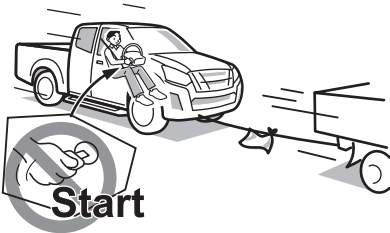

CAUTION

- Do not try to start the engine by pushing or towing the vehicle. You could damage the engine.

When the Battery Goes Flat
 → Refer to page 7-26

Preventing Breakdowns

For Manual Transmission Model, Do not Rest Your Foot on the Clutch Pedal while Driving

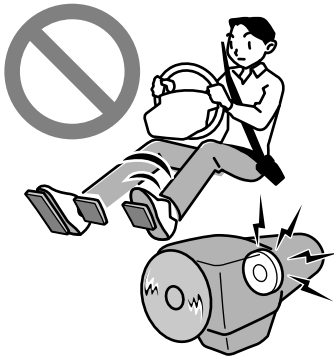

ADVICE

- If you rest your foot on the clutch pedal while driving, the clutch could partially disengage without you realizing it, causing the clutch plates to wear and the clutch to slip. Also, do not slip the clutch as a way to hold the vehicle in position (instead of using the brakes) on, for example, an uphill road.

Do not Ride on the Side Steps while the Vehicle is in Motion



WARNING

- Do not ride on the side steps while the vehicle is in motion.



ADVICE

- Do not jump up and down on the side steps. Doing so may place unnecessary force onto the side steps, resulting in damage.

Is the Engine Oil Dirty?

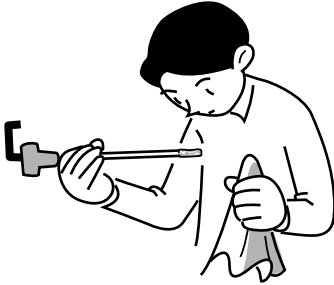

ADVICE

- The engine oil performs the following important functions:
 - It prevents engine parts from becoming worn.
 - It cools engine parts.
 - It cleans engine parts.
 - It seals the combustion chambers and prevents rust.
- Replace the engine oil at regular intervals.

Daily Checks (Preoperational Checks)

→ Refer to page 6-14

Engine Oil

→ Refer to page 6-20

Maintenance Schedule

→ Refer to page 6-122

Do not Leave the Steering Wheel Fully Turned for a Long Time



WARNING

- If you leave the steering wheel fully turned for a long time with the engine running, the fluid in the power steering fluid pump will become extremely hot. This will cause poor lubrication, fluid tank and hose damage and seal deterioration, leading to power steering fluid pump damage, power steering unit damage and power steering hose damage. As a result the steering wheel could become extremely hard to turn and a fire or other accident could occur.

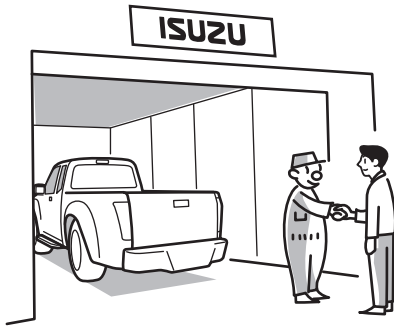
Make Sure the Vehicle is Inspected at Regular Intervals**ADVICE**

- Inspections and maintenance enable you to use the vehicle with peace of mind. They also extend the vehicle's service life.

Daily Checks (Preoperational Checks)

→ Refer to page 6-14

Engine Oil

→ Refer to page 6-20

Maintenance Schedule

→ Refer to page 6-122

When to Visit Your Isuzu Dealer

Do not Modify the Vehicle

⚠ WARNING

- Modification of the suspension/chassis with lift kits, spacers, springs, etc. can cause interference with the steering wheel operation and/or vehicle performance, leading to an accident.

⚠ CAUTION

- Attaching parts that are not suitable for the vehicle's performance and functions could lead to a breakdown or accident. For adjustments (for example, engine adjustments) and equipment installation, consult your Isuzu Dealer.
- If you wish to attach accessories to the vehicle, consult your Isuzu Dealer.



Have Engine Adjustments Made by Your Isuzu Dealer



⚠ CAUTION

- Do not make engine adjustments yourself. Be sure to consult your Isuzu Dealer.

Electric Welding



ADVICE

- Careless electric welding of vehicle parts can cause welding current to flow back through the vehicle's ground circuit and damage electrical and electronic parts so that they do not function normally. Whenever electric welding is necessary, consult your Isuzu Dealer.

Replacing Tires and Wheels



CAUTION

- Consult your Isuzu Dealer before replacing tires or wheels. Never use wheels that are not designed for the vehicle, tires of different types at the same time or tires that are not the specified size. Doing so would impede safe vehicle operation.

Wheels and Tires → Refer to page 6-63

Changing Tires → Refer to page 6-79

Installing Electrical Equipment

**CAUTION**

- Inappropriate installation or removal of audio, radio or other electrical equipment can adversely affect other electrical equipment and cause a breakdown or fire. It can also cause unexpected, dangerous airbag deployment. Be sure to have electrical equipment installed or removed by your Isuzu Dealer.

**ADVICE**

[Installation of radio equipment]

- Do not install any unauthorized radio set, or any radio set or antenna that does not comply with relevant standards. Noise from the radio set could cause electromagnetic interference with the vehicle's electronic equipment and other systems, resulting in a vehicle breakdown or in a malfunction of electronic equipment. Consult your Isuzu Dealer if you wish to install radio equipment.

Using Tire Chains

When handling, installing and uninstalling tire chains, refer to the instruction manual that is supplied with the tire chains and perform (un)installation following the instructions provided by the manufacturer.

Handling the Jack → Refer to page 6-74



CAUTION

- Fit the tire chains securely without looseness. If the vehicle is driven with the loosened tire chains, they may interfere with other components or come off, leading to an unexpected accident.
- Do not exceed 30 km/h (19 MPH) or exceed the tire chain manufacturer's suggested speed limit if it is lower than 30 km/h (19 MPH).
- If an abnormal sound is heard, it may indicate a possibility that a tire chain was cut or came off partially. Immediately pull off to a safe place, and check the fitting condition of the tire chains.
- The diesel particulate defuser (DPD), muffler, and exhaust pipe are extremely hot when the engine is running or immediately after the vehicle is driven, so be careful not to touch them.
- Be careful not to hurt yourself on the edges of the vehicle while working with the tire chains.



ADVICE

- Do not install tire chains on the front tires. Make sure to fit the tire chains suitable for the tire size on the rear wheels.
- If your vehicle has 255/65R17 or 255/60R18 size tires, use tire chains that conform to the following specifications:
 - Radial thickness 13 mm (0.5 in) Max
 - Axial thickness 13 mm (0.5 in) Max
- When purchasing tire chains, fit them on the tires once and, if they are too long, adjust them to suit the tires.
- Retighten chains after driving 0.4 to 0.8 km (0.25 to 0.5 miles).

Diesel Particulate Defuser (DPD)

The DPD purifies diesel exhaust gases of particulate matter (PM). PM is filtered from the exhaust gas and accumulated in the DPD. When PM accumulates to a level predetermined by the engine control module, the DPD automatically burns the PM in a process called regeneration. Regeneration may not be completed under certain driving conditions. If this occurs, the DPD operator regeneration indicator light will flash to prompt for the completion of DPD regeneration.



WARNING

- The DPD, muffler, and exhaust pipe are extremely hot while the engine is running, during DPD regeneration, and immediately after vehicle operation. Be careful not to inadvertently touch them. Otherwise, you could be burned.
- After driving through tall grass, mud, rocks, sand, water, etc., check that there is no grass, branches, paper, rags, stones, sand, etc., adhering to or trapped under the vehicle body. If the vehicle is operated with these materials trapped or adhering to the underbody, a failure or fire could occur. Clear off any such matter from the underbody.
- Before doing maintenance work on the vehicle, shut down the engine and allow it to cool down. Otherwise, you could be burned.



ADVICE

- Always use low ash content engine oil. Also, do not use engine oil additives. Failing to do so could result in DPD failure.
- Be sure to use extra-low-sulfur diesel fuel (containing sulfur of 10 ppm or lower).
- If you fill the vehicle with poor-quality fuel, water-removing additive or other additive, gasoline, kerosene or alcohol-based fuel, it could harm the fuel filter, prevent proper movement of fuel-lubricated parts in the injectors and adversely affect engine components, possibly resulting in a breakdown.
- Do not modify the DPD, muffler, and exhaust pipe. Changing the alignment, length or diameter of the exhaust pipe would adversely affect the exhaust system's exhaust emission reduction function. If any modification is necessary to install a component to the rear of the vehicle, consult your Isuzu Dealer.

ADVICE (Continued)

ADVICE (Continued)

- The DPD performs regeneration automatically when a certain amount of PM accumulates in the DPD. Regeneration occurs during driving and the DPD operator regeneration indicator light does not come on during regeneration. Depending upon driving conditions, however, the regeneration may sometimes not be completed. In this case, the DPD operator regeneration indicator light will flash, so perform operator regeneration as soon as possible according to the "Operator Regeneration Procedure". This operation recovers the function of the DPD. It does not mean that a failure has occurred.
- If the engine idles continuously over an extended period of time, the DPD operator regeneration indicator light may flash. In this case, perform operator regeneration as soon as possible according to the "Operator Regeneration Procedure".

**NOTE**

- During regeneration, white smoke may be temporarily produced from the exhaust pipe. This results from combustion of PM and does not indicate a failure.
- Owing to the exhaust emission reduction function, the exhaust gases emitted by the exhaust pipe smell different from those emitted by the exhaust pipes of earlier diesel vehicles.
- A long continuous idling can cause white smoke to be briefly emitted from the exhaust pipe. The white smoke does not indicate a failure.

Diesel Particulate Defuser (DPD)

→ Refer to page 4-184

Engine Oil

→ Refer to page 6-20

Inspection and Maintenance

Performing regular inspections and maintenance prevents damage. Be sure to perform inspections and maintenance at regular intervals. Also, quickly rectify any fault in the vehicle (even a small fault) to prevent it from becoming more serious.

If a symptom shown in the following table occurs, perform inspections and take corrective action in accordance with the table.

If you are unable to perform a repair, the corrective action shown in the table does not eliminate a symptom or you cannot locate a fault, contact the nearest Isuzu Dealer.

Symptom	Cause	Corrective action	Reference page
White exhaust smoke	Engine not sufficiently warming up	Allow the engine to warm up.	—
	Too much engine oil	Correct the oil level.	6-20
	Engine control system faulty	⊙	—
	Fuel system faulty	⊙	—
	Continuous idling for a long period (more than 2 hours)	With the vehicle stationary in a place where it will not obstruct traffic, hold down the accelerator pedal and check that white smoke is not emitted.	—
Black exhaust smoke	Engine control system faulty	⊙	—
	The air cleaner clogged	Clean or replace the element.	6-50
	Fuel system faulty	⊙	—
	Exhaust system clogged	⊙	—
	DPD faulty	⊙	—



ADVICE

- Any item for which there is a ⊙ in the "Corrective action" column requires repairs and adjustments. Contact the nearest Isuzu Dealer.

Speed Limit Device

Characteristics of the Speed Limit Device

The speed limit device restricts excessive speed to prevent a serious accident.

Set speed
180 km/h (112 MPH)



CAUTION

- The speed limit device does not control braking, so it is possible for the vehicle to exceed the set speed on downhill slopes.



NOTE

- The speed limit device restricts the vehicle's speed by controlling the fuel injection volume. It prevents the speed from exceeding a certain, predetermined level regardless of the pressure on the accelerator pedal.

Front Seat Belt with Pretensioner and SRS Airbag System

The front seat belt with pretensioner and supplemental restraint system (SRS) airbag system is activated in the event of a frontal collision when the impact energy exceeds a certain level to help mitigate the shock to the driver and the passenger by firmly restraining the body of the occupant in the seat with the front seat belt with pretensioner and front airbag. In addition, in models with side airbag and curtain airbag, the front seat belt with pretensioner, side airbag and curtain airbag are activated in the event of a lateral collision when the impact energy exceeds a certain level to help mitigate the shock on the head and chest of the driver and the passenger by firmly restraining the body of the occupant in the seat, and the curtain airbag is activated to mitigate the shock on the head of the occupant sitting in the outboard seats of the models with the rear seat.

Be sure to observe the following instructions to prevent you and your passenger from suffering a serious or fatal injury due to impacts resulting from the front seat belt with pretensioner and airbag operation.

**WARNING**

- Before driving the vehicle, properly adjust your seat for proper driving position and wear the seat belt correctly. Do not sit closer than necessary to the steering wheel and do not lean over it. (Leave a space of 25 cm (10 in) or more between your chest and the center of the steering wheel.) Do not allow the passenger to put his/her hands or feet on the instrument panel and to sit with his/her face or chest close to it. When the airbags are activated, you or the passenger may suffer a burn on or serious injury to the arm or face.
- In models with side airbag and curtain airbag, do not lean against the door and roof side. When the airbags are activated, you may suffer a burn on or serious injury to the arm or face.
- Do not drive the vehicle with something placed between you and airbag or held on your lap. If the airbag inflates, the objects may be thrown and hit your face. Doing so also hinders normal activation of the airbag, which is dangerous.
- Be sure to observe the following precautions when carrying a child in the vehicle. Otherwise the child may be fatally injured by the impact from an inflating airbag.
 - Do not drive with a child standing in front of any of the airbags, or sitting on your lap. Doing so is dangerous as the child would receive a very strong impact due to an inflating airbag.
 - Never use a rearward-facing CRS on a seat protected by an active airbag in front of it, death or serious injury to the child can occur.

Seats → Refer to page 3-48

Seat Belts → Refer to page 3-61

**Front Seat Belt with Pretensioner and
SRS Airbag System**

→ Refer to page 3-80

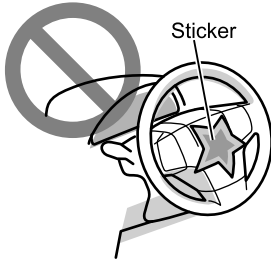

Sticker

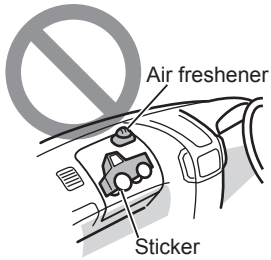

Air freshener

Sticker

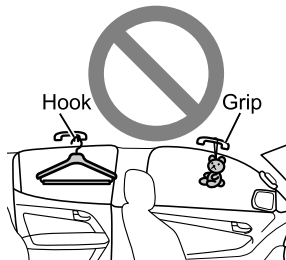

Hook

Grip

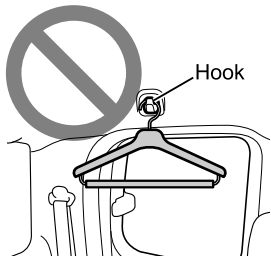

Hook

⚠ WARNING

- If you make unauthorized modifications to the vehicle or install an unauthorized accessory, the front seat belt with pretensioner and airbag may not operate correctly.
- If the steering wheel is changed to a non-standard one or a sticker is attached to the steering wheel pad, there could be a danger of system malfunction or the sticker flying off in the event of system activation. Attaching stickers or placing such things as accessories or air fresheners on the top surface of the instrument panel is also dangerous. They may prevent normal operation of the airbag or could fly off in the event of system activation.
- In models with side airbag and curtain airbag, do not attach seat covers under any circumstances. If a seat cover is attached or objects are placed in the area in which the side airbag inflates, the side airbag will not function correctly. Also, there could be a danger of objects flying off in the event of the system activation. In addition, if hard objects such as hangers or accessories are attached to the grip or coat hook, they may prevent normal operation of the curtain airbag and could fly off in the event of system activation.

WARNING (Continued)

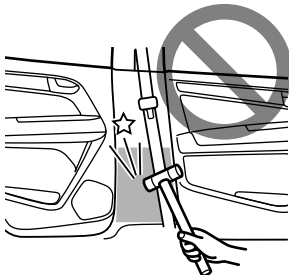
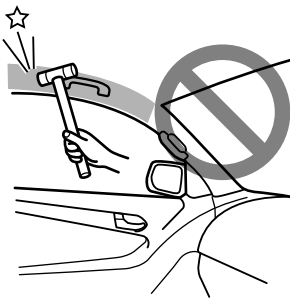
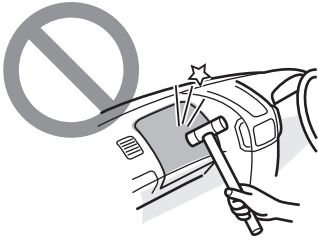

WARNING (Continued)

- Do not apply excessive force to nor strongly hit the airbag installation area or the base of the b-pillar. Doing so may result in erroneous activation of the airbag or the front seat belt with pretensioner.
- Doing any of the following may require special precautions. Be sure to consult your Isuzu Dealer before doing any of the following. Failure to do so may cause the front seat belt with pretensioner and airbag to be unduly activated, causing the seat belt to be unexpectedly retracted or the airbag to be suddenly inflated, causing an injury to the occupant. Doing any of them improperly will adversely affect the operation of the system, causing a malfunction or failure.
 - Repair or replacement of the steering wheel, instrument panel, center console, parts around the accelerator pedal, front seat (in models with side airbag and curtain airbag), parts around the roof side (in models with side airbag and curtain airbag), and parts around the base of the b-pillar.
 - Repair, replacement or disposal of the front seat belt with pretensioner and airbag, or scrapping of a model that has front seat belt with pretensioner and airbag.
 - When audio equipment and accessories are installed or modification such as body mounting is carried out.

WARNING (Continued)

WARNING (Continued)

- Making modifications to the front of the vehicle (bumper, frame, etc.), installing equipment (snow plows, etc.), making modifications to the frame, or making changes to the vehicle's height using unauthorized methods and/or materials.
- Repairing or painting of panels at the front of the vehicle or panels on the cab.

Vehicle Data Collection

Your vehicle, like other modern motor vehicles, has a number of sophisticated computer systems that monitor and control several aspects of the vehicle's performance. Your vehicle uses on-board vehicle computers to monitor emission control components to optimize fuel economy, to monitor conditions for airbag deployment, to provide anti-lock braking and to help the driver control the vehicle in difficult driving situations. Some information may be stored during regular operations to facilitate repair of detected malfunctions.

Isuzu may download and retrieve stored information for the purpose of diagnosing, servicing, or repairing your motor vehicle or improvement to future Isuzu motor vehicles.

Turbocharger

Engine Starting in General

The turbocharged engine should be started in a way which ensures the bearings supporting the rotating parts of the turbocharger are sufficiently lubricated. Do not race a cold engine.

Engine Shut-off in General



ADVICE

- After driving for an extended period of time with a heavy load, it is recommended that you idle the engine for a few minutes to cool it down, and then turn off the engine. This allows the turbocharger to return to idle speed. Engine oil pressure is available for lubrication at this time and will prolong the life of the turbocharger bearings.

PRE-DRIVING OPERATIONS AND ADJUSTMENTS

3

• Key	3-2
• Key with Immobilizer Transponder Chip	3-4
• Passive Entry and Start System/Keyless Entry System (Radio Remote Control Units for Door-lock)	3-7
• Anti-theft System	3-20
• Opening and Closing Doors	3-25
• Child-proof Door Locks (Crew Cab Model)	3-34
• Tailgate	3-35
• Getting In and Out of the Vehicle	3-38
• Power Windows	3-39
• Manually Operated Windows	3-44
• Fuel Tank Filler Cap	3-45
• Seats	3-48
• Tilt Steering	3-58
• Mirrors	3-59
• Seat Belts	3-61
• Child Restraint System (CRS)	3-68
• Front Seat Belt with Pretensioner and SRS Airbag System	3-80

Key

Type 1

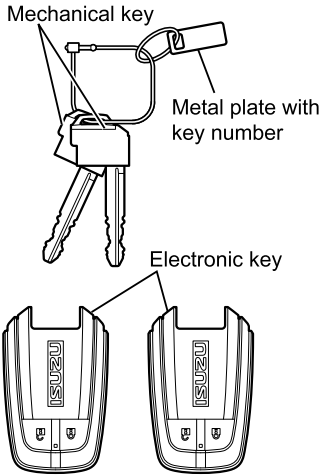

Both sides of the key are identical, so you can insert the key in the key cylinder without worrying about which way you insert it.

The key number is indicated on a separate metal plate in order to prevent it from being acquired by an unauthorized person.



NOTE

- In models with a passive entry and start system, the mechanical key is stored in the electronic key.
- The number of keys and their combinations depend on the model of vehicle.

Type 2

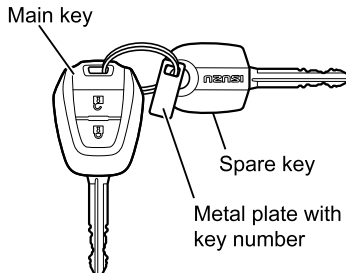

Passive Entry and Start System

→ Refer to page 3-11

Type 3

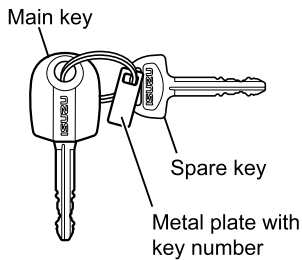

Where Is the Key Used?

Where	For what
Starter switch (models without passive entry and start system)	Starting and stopping the engine
Driver side door	Locking and unlocking the door
Passenger side door (with key cylinder)	Locking and unlocking the door
Tailgate (with key lock)	Locking and unlocking the tailgate
Fuel tank filler cap (with key lock)	Locking and unlocking the filler cap
Glove compartment	Locking and unlocking the glove compartment
Rear door (crew cab model)	Locking and unlocking the child-proof door locks
Rear center seat belt (crew cab model)	Disconnect the anchor buckle and anchor latch plate



ADVICE

- Wipe off the key to remove any dirt or dust, etc. before using it.



NOTE

- To prevent theft, store the metal plate with key number in a safe place other than the vehicle.
- Should you lose the key, please give the key number and all remaining keys supplied with the vehicle to the nearest Isuzu Dealer. The Isuzu Dealer will be able to duplicate your key.
- If you resell the vehicle, be sure to hand over the plate with key number to the new owner together with the vehicle.

Key with Immobilizer Transponder Chip

The immobilizer key and electronic key contain an immobilizer transponder chip. The immobilizer anti-theft system allows the engine to be started only when it receives signals from the transponder of the pre-registered key.

**NOTE**

- In models with passive entry and start system, the electronic key contains a transponder chip, and when the electronic key battery goes flat, the power mode can be changed and the engine can be started through verification of the transponder chip. Refer to "When the Electronic Key Battery Goes Flat" for details.
- In models without passive entry and start system, when the starter switch is turned to the "ON" position, verification of the transponder chip will be performed. If the verification is successful, it will become possible to start the engine. Also, after the starter switch is turned from the "ON" position to the "ACC" or "LOCK" position and a maximum of approximately 30 seconds has passed, it will be necessary to perform verification again in order to start the engine.

Engine Start/Stop Button (Models with Passive Entry and Start System)

→ Refer to page 4-116

Starter Switch (Models without Passive Entry and Start System)

→ Refer to page 4-119

When the Electronic Key Battery Goes Flat

→ Refer to page 7-7

However, even when using the pre-registered key, you might not be able to start the engine in the cases listed below. If the engine fails to start due to a metal key holder, remove the key holder and then try again.

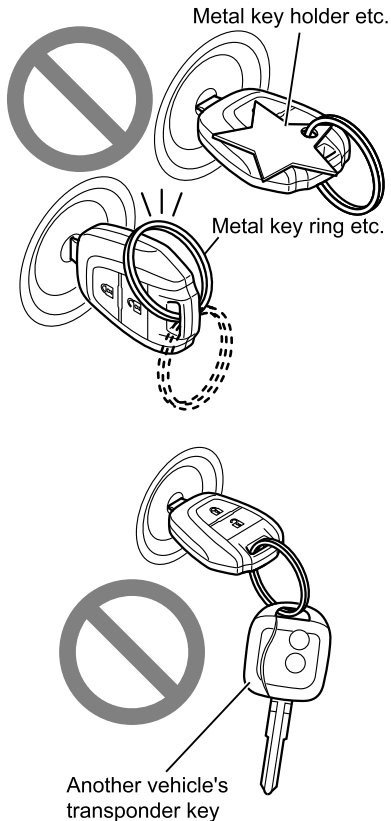

- There is a facility nearby that is emitting strong radio waves.
- A metallic object is touching or covering the handle of the key.
- Placing items which interfere with the immobilizer signal onto the key grip. (Ex. key ring, key number plate, metal items, magnetic items)

- Another vehicle's transponder key is near your key (includes an Isuzu spare key and other keys).

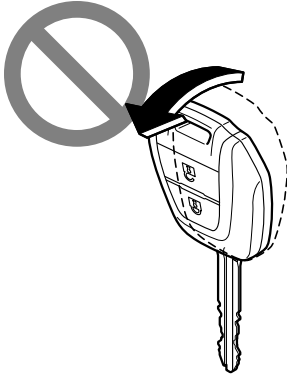
**ADVICE**

- Should you lose your transponder key, contact the nearest Isuzu Dealer.
- Do not leave the transponder key on the dashboard or any other surface where the key might be exposed to high temperatures (exceeding 60°C /140°F).
- Do not place a magnetic object close to the transponder key.
- No alterations or additions should be made to the immobilizer system, as such alterations or additions would automatically invalidate the certificate of installation.
- For starting the engine, use only the Isuzu immobilizer keys which are registered to the immobilizer system in your vehicle. Do not use copied keys or any other keys.
- Do not break the key.
- Do not try to open the key grip (except replacing the battery in remote control unit).
- Do not dip the key into water or any other liquid.
- Do not wash the key with an ultrasonic cleaner.

**NOTE**

- The immobilizer system does not lock the doors, so please do not forget to lock the doors when you get out of the vehicle.
- If the starter will not turn even though key usage is correct and the condition of the battery is normal, there may be a failure of the immobilizer system. If this occurs, contact the nearest Isuzu Dealer.

Passive Entry and Start System/Keyless Entry System (Radio Remote Control Units for Door-lock)



WARNING

- No alterations or additions should be made to the passive entry and start system or keyless entry system (radio remote control units for door-lock), as such alterations or additions would automatically invalidate the certificate of installation.



NOTE

- Passive entry and start system (EMU470003) consists of TX (EMU470102), RF unit (EMU370502), push switch (EMU470601), and passive entry and start system ECU (EMU47071).
- Keyless entry system (EMU370001/radio remote control units for door-lock) consists of TX (EMU370101), RF unit (EMU370501), and BCM (EMU370851).

Locking and Unlocking the Doors Using the Remote Control Unit

Remote control operating range

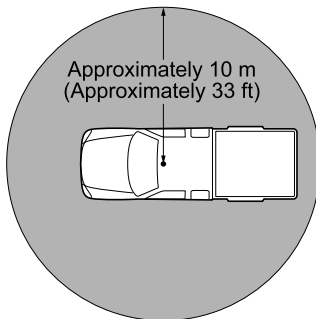

The passive entry and start system and keyless entry system (radio remote control units for door-lock) allow you to lock/unlock the doors by simply pressing the button on the remote control unit without inserting the key into the lock.

The remote control unit works within approximately 10 m (approximately 33 ft) radius of the vehicle center as indicated in the figure.

Remote control unit (electronic key)

Lock button Unlock button

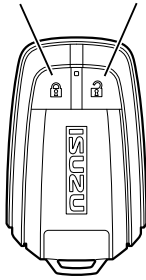
**Remote control unit (keyless entry key)**

Lock button Unlock button

**Locking**

Press the lock button on the remote control unit for 0.4 seconds or longer. When the vehicle receives the signal, the hazard warning flasher will flash once and all the doors will lock. At this time, in models with passive entry and start system, the answerback buzzer will sound once. If the dome light or map light is on with the switch in the door position, the lights go out.

Unlocking

Press the unlock button on the remote control unit for 0.4 seconds or longer. When the vehicle receives the signal, the hazard warning flasher will flash twice and all the doors will unlock. At this time, in models with passive entry and start system, the answerback buzzer will sound twice. If the doors are unlocked with the dome light or map light switch in the door position, the lights come on for about 30 seconds.

**ADVICE**

- Should you lose the remote control unit, please contact your Isuzu Dealer.
- After locking the doors using the remote control unit, be sure to check that they are locked by pulling the door handles.
- Avoid getting water on the remote control unit, dropping it, hitting it against another object, or stepping on it; otherwise, the remote control unit could malfunction.
- The remote control unit is comprised of precision components. Do not disassemble or subject the remote control unit to electrical shock.
- Do not leave the remote control unit on the dashboard or any other surface where the unit might be exposed to high temperatures (exceeding 60°C/140°F). Doing so may result in shorter battery life or malfunction of the remote control unit.
- Repeatedly locking and unlocking the doors using the remote control unit in succession may trigger the protection circuit in the system, preventing the unit from working. If this happens, wait for a while. The system will then work normally.
- If the function fails to operate normally, lock and unlock the doors using the key and have the system inspected by your Isuzu Dealer.

**NOTE**

- After unlocking the doors using the remote control unit, the door will automatically relock in the following cases:
 - The door is not opened within 30 seconds.
 - The engine start/stop button is not pushed within 30 seconds in models with passive entry and start system.
 - The key is not inserted into the starter switch within 30 seconds in models with keyless entry system (radio remote control units for door-lock).
- In areas near a TV tower, electric power plant, radio station, etc. or under any conditions involving strong electrical disturbances, the remote control operating range might change or the function might not work.
- The function does not operate in the following cases:
 - One of the doors is open.
 - The power mode is in a mode other than "OFF" in models with passive entry and start system.
 - The key is inserted in the starter switch in models with keyless entry system (radio remote control units for door-lock).

Passive Entry and Start System

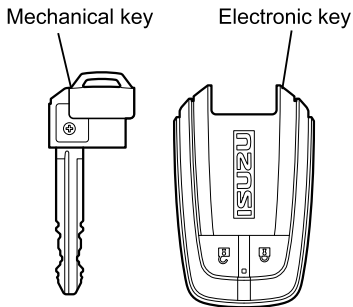
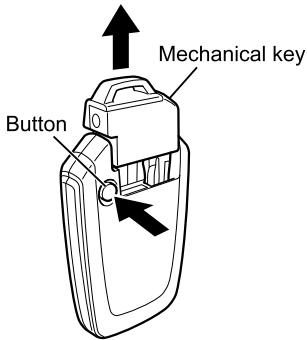

The passive entry and start system is a system that enables doors to be locked and unlocked and for the engine to be started remotely just by carrying the electronic key in your pocket.

Use the mechanical key to lock/unlock the doors when either the battery for the electronic key or that of the vehicle goes flat.

Pull out the mechanical key while pressing the button on the electronic key.

When storing the mechanical key in the electronic key, insert until a clicking sound is heard.



NOTE

- Keep the mechanical key stored in the electronic key for use in such cases as when electronic key battery goes flat or is broken.
- When the vehicle battery is weak or the voltage is low, the passive entry and start system function may not be possible. In this case, use the mechanical key to unlock the doors, and check the battery of the vehicle.
- The electronic key conforms to the stipulations of the radio law. Please refrain from doing the following:
 - Do not open the electronic key except for when replacing the battery.
 - Do not use electronic keys that have been modified.

Locking and Unlocking the Front Doors
→ Refer to page 3-26

When the Electronic Key Battery Goes Flat
→ Refer to page 7-7

Handling the Battery
→ Refer to page 6-101

Weak Radio Waves Emitted from Passive Entry and Start System

External (driver side door handle) antenna
In-vehicle (rear inner panel) antenna (crew cab model)

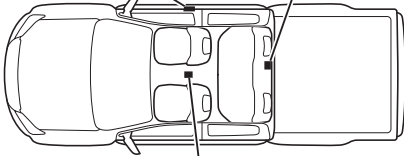

In-vehicle (center console) antenna

External (driver side door handle) antenna
In-vehicle (rear inner panel) antenna (crew cab model)

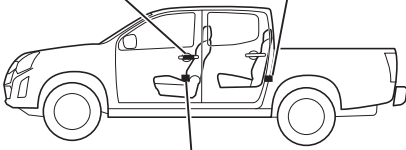

In-vehicle (center console) antenna

When using the passive entry and start system to lock/unlock the doors or to start the engine, radio waves will be transmitted from the vehicle's antenna in order to perform electronic verification.

Because of that, the passive entry and start system may not operate properly or consistently due to the following causes:

- When there is a facility nearby that is emitting strong radio waves.
- When communication devices such as mobile phones, two-way radios, or laptops are within the vicinity of the electronic key.
- When other metallic objects are touching or covering the electronic key.



CAUTION

- Individuals with implanted cardiac pacemakers or implanted defibrillators should keep a distance of at least 22 cm (8.7 in) from any antennas installed to the vehicle. Radio waves emitted from passive entry and start system may affect the operation of such devices. Individuals using electronic medical devices should consult with the manufacturer of the device or with their doctor before use.
- When taking the electronic key on airplanes, do not press the key buttons while in the cabin of the plane. Also, when storing the key in bags, etc., store so that the key buttons are not easily pressed. Radio waves will be emitted should the buttons be pressed, possibly interfering with the operation of the plane.

Locking and Unlocking the Doors Using the Passive Entry and Start System

Operating range for locking and unlocking the doors

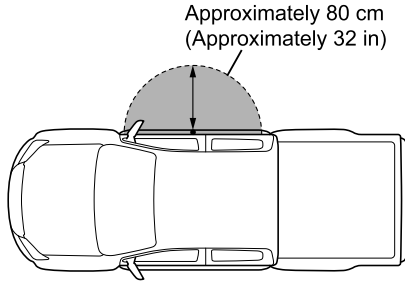

By carrying the electronic key, it is possible to lock or unlock the doors by operating the lock button or door handle on the driver side door. The key must be within approximately 80 cm (32 in) of the driver side door handle, in order to lock or unlock the doors.

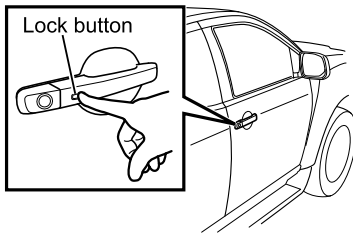

Locking

Press the lock button on the driver side door handle. The answerback buzzer will sound once and the hazard warning flasher will flash once, locking all of the doors. If the dome light or map light is on with the switch in the door position, the lights go out.

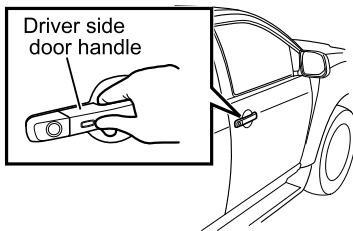

Unlocking

Grip the driver side door handle. The answerback buzzer will sound twice and the hazard warning flasher will flash twice, unlocking all of the doors. If the doors are unlocked with the dome light or map light switch in the door position, the lights come on for about 30 seconds.

**NOTE**

- If snow, ice, mud, etc., becomes attached to the sensor portion on the inside of the door handle, it may not be possible to unlock the doors even by gripping the door handle. In such cases, unlock the doors by removing the obstruction and gripping the handle again, or by pressing the lock button on the door handle for at least 2 seconds. The setting of door unlocking by pressing the lock button can also be changed. To change the setting, please contact your Isuzu Dealer.
- The driver should keep the electronic key with them and avoid leaving the key in the vehicle.
- If the person with the electronic key is within operating range for locking and unlocking the doors, other people may also lock or unlock the doors by operating the lock button or door handle.
- When wearing leather or thick gloves, the door handle unlocking function may not operate properly or consistently.
- When the electronic key is within operating range for locking and unlocking the doors, the doors may unlock due to large amounts of water flowing over the driver side door handle in a strong rain or when the car is washed.
- Within approximately 2 seconds after locking, it will not be possible to unlock the doors even by gripping the door handle. Be sure to check that the doors are locked by pulling the door handle.
- It may sometimes not be possible to open the door by pulling the door handle immediately after gripping it. Pull on the door handle only after gripping the door handle and confirming the unlock answerback buzzer. If the door does not open, grip the door handle again within 10 seconds or press the unlock button on the remote control unit (electronic key), and pull on the door handle after confirming that the door is unlocked.
- Even when the electronic key is within approximately 80 cm (32 in) of the door handle on the driver side door, it may not operate if it is too close to the ground or high in the air.
- The electronic key may not operate if it is too close to the door or glass.
- The passive entry and start system will not lock the doors in the following cases:
 - The power mode is other than "OFF".
 - The electronic key is within operating range for starting the engine.
 - One of the doors is open.

Regarding Customizing Functions

It is possible to turn off or adjust the volume of the answerback buzzer that sounds when locking and unlocking. For further details, please contact your Isuzu Dealer.

Item	Setting
Answerback buzzer volume	Max* Middle Low
Answerback buzzer operation	On* Off

*Factory default settings

Lockout Prevention Buzzer

Models with Passive Entry and Start System

If door locking is attempted by pressing the lock button on the driver side door handle when the electronic key is within operating range for starting the engine, the warning buzzer will sound.



NOTE

- Even when the electronic key is within the operating range for starting the engine, the warning buzzer may not sound due to radio wave conditions.
- Even when the electronic key is within the operating range for starting the engine, the warning buzzer may not sound if the electronic key battery voltage is low.
- The warning buzzer may not sound due to radio wave conditions when the electronic key is placed on the instrument panel and dashboard, in storage areas such as the glove box or door pocket, or when under the seat or on the floor in front of the driver and passenger seats, etc.

Warning Buzzer → Refer to page 4-111

No Electronic Key Warning Buzzer

Models with Passive Entry and Start System

The warning buzzer will sound in the following cases:

- If the electronic key is carried outside the vehicle and then the doors are closed with the power mode in "ACC" or "ON".
- If the power mode is "OFF" and the engine start/stop button is pushed with the electronic key not within operating range for starting the engine.
- If locking of an unlocked door is attempted with the electronic key not within operating range for locking and unlocking the doors.

At this time, the multi-information display (MID) will display "NO ELECTRONIC KEY".

**NOTE**

- Even when the electronic key is within the operating range for locking and unlocking the doors or the operating range for starting the engine, the warning buzzer may sound due to radio wave conditions. In this case, change the location of the electronic key.
- When the vehicle battery is weak or the voltage is low, the warning buzzer may sound when pressing the lock button on the driver side door handle, or when pushing the engine start/stop button. In this case, check the battery of the vehicle.
- If the electronic key is passed through an open window and carried outside of the vehicle, the buzzer will not sound.
- The warning buzzer may sound due to radio wave conditions when the electronic key is placed on the instrument panel and dashboard, in storage areas such as the glove box or door pocket, or when under the seat or on the floor in front of the driver and passenger seats, etc.
- If the power mode is "OFF" when the electronic key is carried outside of the vehicle, engine start/stop button operation will not be possible. When operating the engine start/stop button, ensure that you are carrying the electronic key.
- Even if the electronic key is within operating range for starting the engine, a warning buzzer may sound due to the surrounding environment or radio wave conditions. As this is not a malfunction, ensure that you are carrying the electronic key.

No Electronic Key Warning Light

→ Refer to page 4-91

Warning Buzzer → Refer to page 4-111**Handling the Battery**

→ Refer to page 6-101

Low Battery Electronic Key Warning Buzzer**Models with Passive Entry and Start System**

If the power mode is switched from "ON" to "OFF" (or "ACC") when the battery voltage of the electronic key is low, the warning buzzer will sound and "LOW BATTERY ELECTRONIC KEY" will be displayed in the multi-information display (MID).

Low Battery Electronic Key Warning Light

→ Refer to page 4-96

Warning Buzzer → Refer to page 4-111**Replacing the Battery in the Remote****Control Unit** → Refer to page 3-17

Replacing the Battery in the Remote Control Unit

Replace the battery as soon as the range of the remote control starts to become reduced.



CAUTION

- When changing the battery, use only a battery of the same type as the original battery, or an equivalent. Otherwise, there is a risk of explosion.
- Do not place the battery in direct sunlight, or near a fire or other sources of heat.
- Be sure to install the battery with the "+" side and the "-" sides correctly oriented. Incorrect installation will result in leakage of chemicals from inside the battery or other operational problems.



NOTE

- The battery life varies depending on how the remote control unit is used. As a guide, in models with passive entry and start system, battery life is approximately 1 to 2 years. Also, significant wasting may occur if strong radio waves are continually received. Do not place the remote control unit near appliances such as televisions or computers.
- The battery has reached its end of life when the remote control unit works intermittently or does not work at all. Replace the battery as soon as this happens.
- Please comply with the collection system available in your country for the disposal of old batteries. In addition, take special care to prevent any danger to children.

This symbol [crossed-out wheeled bin] provided in Directive 2006/66/EC of the European Parliament and of the Council indicates separate collection of waste batteries in the European Union countries.



Electronic Key

Battery used	Number of batteries
Lithium battery Model number: CR2032 Voltage: DC3V	1

1. Pull out the mechanical key while pressing the button on the electronic key.

Passive Entry and Start System

→ Refer to page 3-11

2. Pry open the cover by inserting a flat-head screwdriver. Wrap a piece of cloth or tape around the tip of the screwdriver so as not to damage the cover.
3. Remove the battery.
4. Insert a new battery and close the cover.

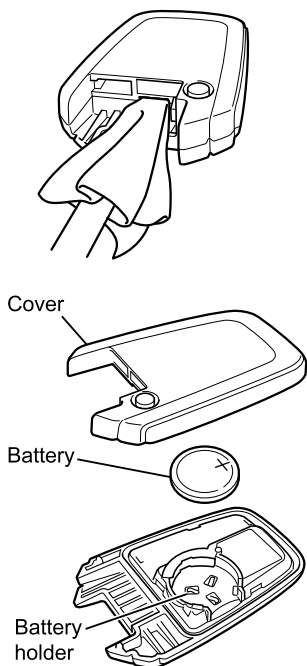
**ADVICE**

- Be careful not to bend the electrode when placing a new battery.
- When closing the cover, check that there is no dust or hair or anything else caught underneath it. A poorly sealed remote control unit could become deteriorated.

5. Store the mechanical key in the electronic key.

Keyless Entry Key

Battery used	Number of batteries
Lithium battery Model number: CR1620 Voltage: DC3V	1

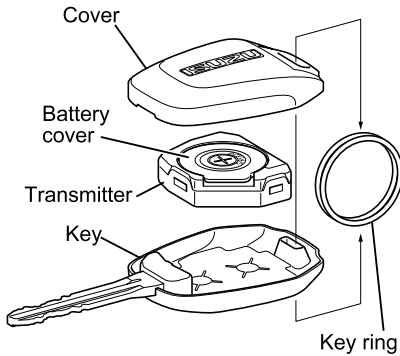

1. Remove the key ring and pry open the cover by inserting a flat-head screwdriver. Wrap a piece of cloth or tape around the tip of the screwdriver so as not to damage the cover. Remove the transmitter.

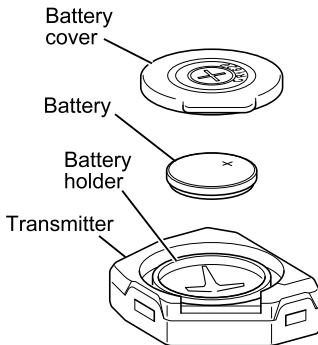

2. Open the battery cover and remove the battery.
3. Insert a new battery and close the battery cover.



ADVICE

- Be careful not to bend the electrode when placing a new battery.
- When closing the battery cover and key cover, check that there is no dust, hair or anything else caught underneath it. A poorly sealed remote control unit could become deteriorated.

4. Place the transmitter in the key and close the cover.

Anti-theft System

WARNING

- No alterations or additions should be made to the anti-theft system, as such alterations or additions would automatically invalidate the certificate of installation.

When the vehicle doors and engine hood are locked, the anti-theft system is designed to protect your vehicle and valuables from theft.

Any attempt to forcibly open any door or the engine hood without using the passive entry and start system or keyless entry system (radio remote control units for door-lock) will cause the hazard warning flasher to flash on and off and the horn to sound intermittently. After the system activates, the hazard warning flasher will shut off automatically after 5 minutes, and the horn will shut off after 30 minutes.

Please lock the door with the passive entry and start system or keyless entry system (radio remote control units for door-lock) after closing all the doors and engine hood to arm the alarm system.

Activating the Anti-theft System

1. In models with passive entry and start system, switch the power mode to "OFF". In models with keyless entry system (radio remote control units for door-lock), turn the starter switch to the "LOCK" position and remove the key.
2. Closing all the doors and the engine hood then locking all of the doors with the passive entry and start system or keyless entry system (radio remote control units for door-lock) will cause the indicator light to come on.
3. After approximately 10 seconds, the indicator light will flash. The anti-theft system is now in operation. (In models with super lock, the super lock system will be activated immediately after it is initiated.)

Super Lock (Mechanical Anti-theft Locking System) → Refer to page 3-23

Indicator Light

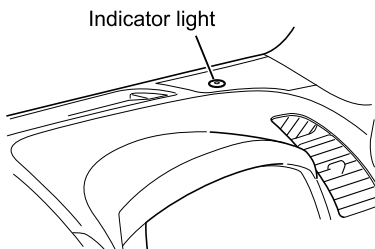

During the first 10 seconds	
Lights up	System in preparation
Flashes	Door, engine hood open or system fault

After approximately 10 seconds	
Flashes	System on
Goes off	System off

**CAUTION**

- If a door is not closed completely, the map light or dome light will remain on. The anti-theft system is not engaged at this time.

Anti-theft System Alarm Operating Conditions

When the anti-theft system is engaged, the alarm will operate under the following conditions:

1. When someone forcibly attempts to open the door or engine hood without using the passive entry and start system or keyless entry system (radio remote control units for door-lock).
2. When a key or other tool is inserted into the door key cylinder and a door is unlocked.
3. When someone unlocks a door with the door lock knob or power door lock (central door lock) switch.
4. When the engine hood release lever is operated.

**NOTE**

- A person sitting in the vehicle or reaching into the vehicle through an open window can cause the alarm to sound by inadvertently operating one of the controls (Items 3 and 4 in "Anti-theft System Alarm Operating Conditions").

Deactivating the Anti-theft System and Alarm

When the door is unlocked using the passive entry and start system or keyless entry system (radio remote control units for door-lock), the anti-theft system and alarm will be deactivated.



CAUTION

- If the indicator light is not functioning, have Isuzu Dealer correct the problem as soon as possible.



NOTE

- If the key is inserted into the key cylinder and the doors are unlocked, the horn will sound and the hazard warning flasher will flash on and off. To stop the horn and hazard warning flasher, perform either of the following operations:
 - Push the engine start/stop button to switch the power mode to "ON" (models with passive entry and start system).
 - Insert the key into the starter switch and turn it to the "ON" position in models with keyless entry system (radio remote control units for door-lock).
 - Operate the remote control unit.
- In models with passive entry and start system, when the electronic key cannot be used due to its battery being discharged, touch the button with the electronic key after pushing the engine start/stop button, then push the button and switch the power mode to "ON" to stop the alarm.

When the Electronic Key Battery Goes Flat → Refer to page 7-7

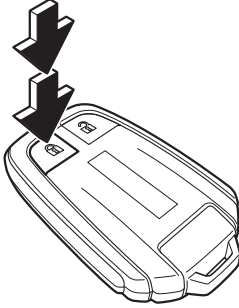
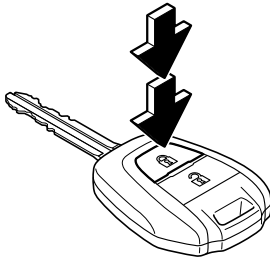
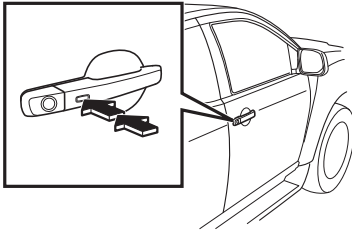
Super Lock (Mechanical Anti-theft Locking System)**Remote control unit (electronic key)****Remote control unit (keyless entry key)****Driver side door handle (passive entry and start system)****Locking**

All doors must be closed. Press the lock button on the remote control unit again within 10 seconds after locking. The hazard warning flasher will flash twice only when the super lock is activated. At this time, in models with passive entry and start system, the answerback buzzer will sound twice. Lock buttons on all doors are positioned such that doors cannot be opened.

In models with passive entry and start system, after pressing the lock button on the driver side door handle once to lock the door, pressing the lock button again within 10 seconds while in possession of the electronic key also activates the super lock.

**WARNING**

- Do not use the system if there are people in the vehicle. The doors cannot be unlocked from inside.

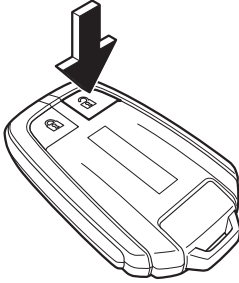
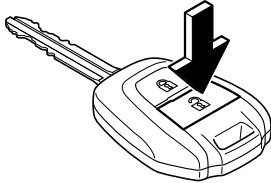
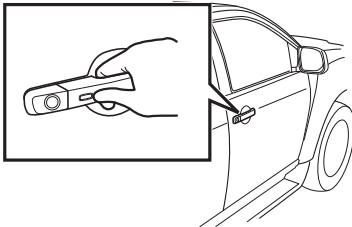
Remote control unit (electronic key)**Remote control unit (keyless entry key)****Driver side door handle (passive entry and start system)****Unlocking**

Press the unlock button on the remote control unit. When the super lock is deactivated, the hazard warning flasher will flash once. At this time, in models with passive entry and start system, the answerback buzzer will sound once.

In models with passive entry and start system, gripping the driver side door handle while in possession of the electronic key also deactivates the super lock.

**CAUTION**

- Unlocking is not possible in any other way, so keep the remote control unit to hand in a safe place.

**NOTE**

- If you use the key to open the vehicle door, the horn will sound and the hazard warning flasher will flash on and off.
To stop the horn and hazard warning flasher, perform any of the following operations:
 - Push the engine start/stop button to switch the power mode to "ON" (models with passive entry and start system).
 - Insert the key into the starter switch and turn it to the "ON" position in models with keyless entry system (radio remote control units for door-lock).
 - Grip the driver side door handle while in possession of the electronic key (models with passive entry and start system).
 - Press the unlock button on the remote control unit.

Opening and Closing Doors



CAUTION

- Be sure to do the following whenever you leave the vehicle: 1) Fully engage the parking brake. 2) Stop the engine. 3) Lock the doors.
- When you close the door after sitting behind the steering wheel, check that the door is fully closed. If the door is not properly closed, it may open while the vehicle is in motion.
- Before opening the door when climbing into or out of the cab, carefully check all areas around the vehicle for safety, especially the area at the rear of the vehicle. If you abruptly open the door, it may be struck by a vehicle, etc. coming from behind.
- Never leave the key in the vehicle.



NOTE

[Impact sensing auto door-unlocking function]

- Models with a passive entry and start system or keyless entry system (radio remote control units for door-lock) also feature an impact sensing auto door-unlocking function that automatically unlocks all the doors when the vehicle is subjected to a strong impact from the front, left, or right side with the power mode in "ON" (models with passive entry and start system) or the starter switch in the "ON" position (models with keyless entry system).
- When the impact-sensing auto door-unlocking function activates, the hazard warning flasher will flash to alert the driver of an abnormality at the same time. In order to stop the hazard warning flasher, switch the power mode to "OFF" once before switching the power mode back to "ON" (models with passive entry and start system), or turn the starter switch to the "LOCK" position once before turning the starter switch back to the "ON" position (models with keyless entry system).
- However, depending on the manner in which the impact is applied, this function may not activate.

Locking and Unlocking the Front Doors

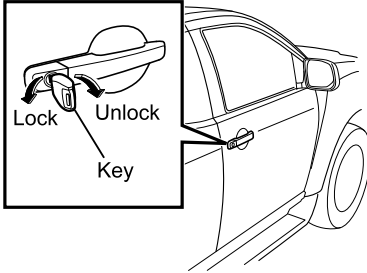

Locking and Unlocking the Door from Outside Using the Key

Turn the key toward the rear of the vehicle to lock the door and turn it toward the front of the vehicle to unlock it.



NOTE

- In models with a passive entry and start system, use the mechanical key stored in the electronic key.
- In models with a power door lock (central door lock) system, all the doors will lock/unlock when the key is used to lock/unlock the doors. However, even in models with a power door lock (central door lock) system, only the driver side door will lock/unlock in the case of models with a passive entry and start system and models with keyless entry system (radio remote control units for door-lock).
- When leaving the vehicle, be sure to check that the doors are locked.

Passive Entry and Start System

→ Refer to page 3-11

Locking and Unlocking the Door from Inside

Push the lock knob forward until the red mark can no longer be seen for lock and pull the lock knob backward for unlock.

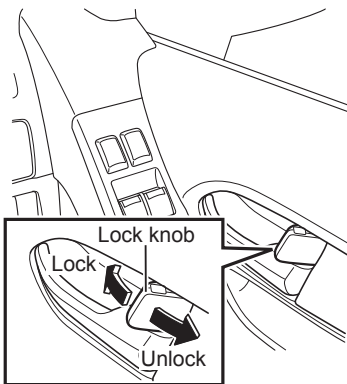

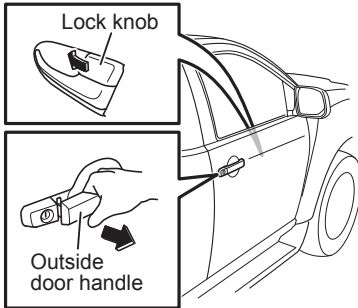

Locking the Door from Outside without Using the Key

First, push the lock knob forward until the red mark can no longer be seen, then close the door while keeping the outside door handle raised.



NOTE

- Before closing the door, be sure to check that you have the key with you.

Locking and Unlocking the Rear Doors (Crew Cab Model)

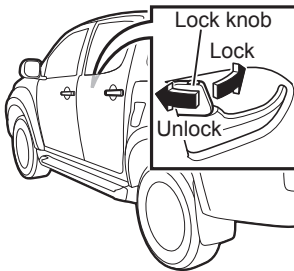

Locking and Unlocking the Door from Inside

Push the lock knob forward until the red mark can no longer be seen for lock and pull the lock knob backward for unlock.

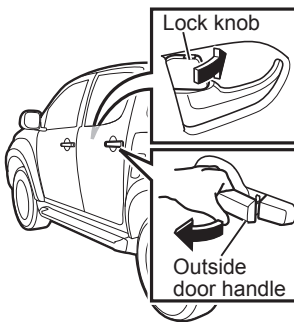

Locking the Door from Outside

First, push the lock knob forward until the red mark can no longer be seen, then close the door while keeping the outside door handle raised.

ACC Mode Reminder Buzzer

Models with Passive Entry and Start System

If the driver's door is opened when the power mode is "ACC", a buzzer will sound to warn that the power mode is not switched to "OFF". When the power mode is switched to "OFF", the warning buzzer will stop sounding.

Warning Buzzer → Refer to page 4-111

Key Reminder Buzzer

Models without Passive Entry and Start System

If the driver's door is opened when the starter switch is in the "ACC" or "LOCK" position, a buzzer will sound to warn that the key has not been removed. When the key is removed, the warning buzzer will stop sounding.

Warning Buzzer → Refer to page 4-111

Power Door Lock (Central Door Lock)

Power door lock switch

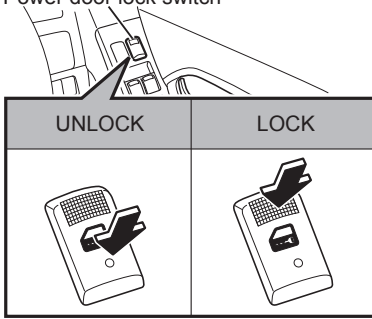

Switch-operated Type

When the power door lock switch on the driver's door is operated, the power door lock system will automatically lock or unlock all doors simultaneously.

Lock knob

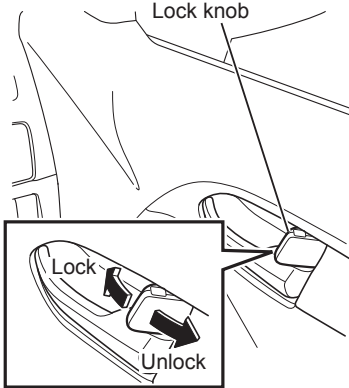

Knob-operated Type

When the lock knob on the driver's door is operated, the power door lock system will automatically lock or unlock all the doors simultaneously.

Power Mode Linked Door Unlocking

Models with Passive Entry and Start System

This function will unlock all the doors in the following cases:

- When the power mode is switched from "ON" to "OFF".
- When the power mode is left in "ACC" for 60 minutes.



NOTE

- Please be aware that all the doors will be unlocked after the power mode has been left in "ACC" for 60 minutes.
- The setting for power mode linked door unlocking can be changed. To change the setting, please contact your Isuzu Dealer.

Engine Start/Stop Button (Models with Passive Entry and Start System)

→ Refer to page 4-116

Key Linked Door Unlocking

Models with Keyless Entry System (Radio Remote Control Units for Door-lock)

When the key is removed from the starter switch, all the doors will be unlocked.



NOTE

- The key linked door unlocking setting can also be changed so that all the doors are unlocked when the starter switch is turned from the "ON" to "LOCK" position. To change the setting, please contact your Isuzu Dealer.

Opening and Closing the Front Doors

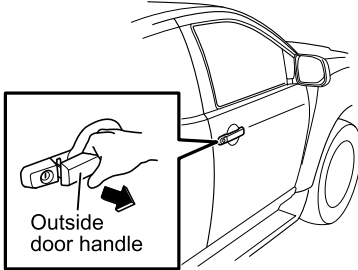

From Outside the Vehicle

To open the door, pull the outside door handle.

To close the door, push the outside door handle.

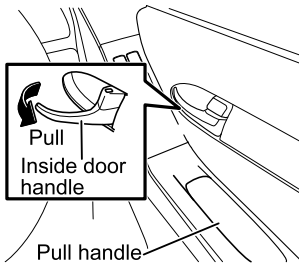

From Inside the Vehicle

To open the door, pull the inside door handle.

To close the door, pull the pull handle.



ADVICE

- Before leaving the vehicle, be sure to stop the engine and lock the doors. Never leave the key behind the door.

Opening and Closing the Side Access Panel (Extended Cab Model)



CAUTION

- Before opening the side access panel, check that the passenger in the front seat has removed his/her seat belt. If the side access panel is opened while the seat belt is worn, the seat belt will lock and it will not be possible to pull it out. The passenger in the front seat may become trapped and could be injured.
- Because it will not be possible to close the front door securely when the side access panel is half-open, it may open while the vehicle is in motion.



ADVICE

- Do not open or close the side access panel while the front door is not completely open. Otherwise, the side access panel may contact the front door and could be damaged.
- Do not open or close the front door and side access panel at the same time. Otherwise, the side access panel may contact the front door and could be damaged.
- After closing the front door, do not close the side access panel. Otherwise, the side access panel may contact the front door and could be damaged. Always close the front door after first closing the side access panel.



NOTE

- The side access panel cannot be opened when the front door is closed.

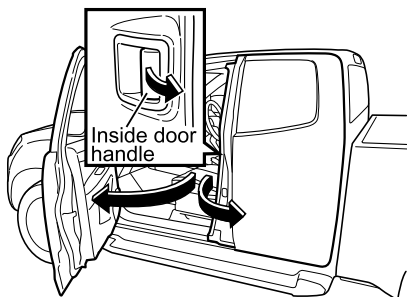

From Outside the Vehicle

To open the door, after first opening the front door, pull the inside door handle and open the side access panel.

To close the door, after closing the side access panel, push the outside door handle of the front door and close the door.

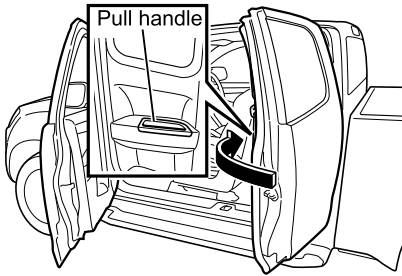

From Inside the Vehicle

To open the door, push the inside door handle while the front door is open.

To close the door, pull the pull handle while the front door is open.

Opening and Closing the Rear Doors (Crew Cab Model)

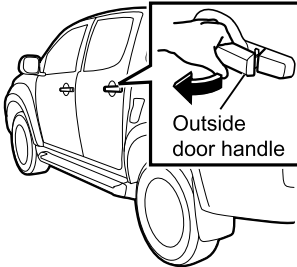

From Outside the Vehicle

To open the door, pull the outside door handle.

To close the door, push the outside door handle.

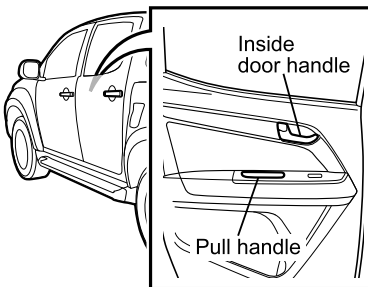

From Inside the Vehicle

To open the door, pull the inside door handle.

To close the door, pull the pull handle.

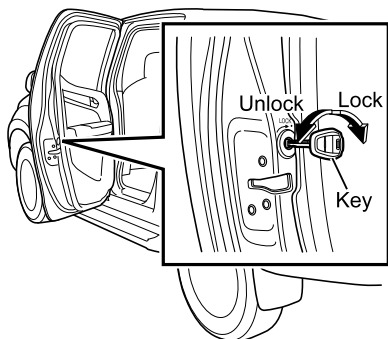
Child-proof Door Locks (Crew Cab Model)

Use the locks if you are traveling with a child in the vehicle. Use the key for the child-proof function of the opening of the rear door. Regardless of the position of the lock knob, it will no longer be possible to open the rear door from inside the vehicle.

When opening the rear door, check that the lock knob is in the lock release position and use the outside door handle to open the door.

**NOTE**

- In models with a passive entry and start system, use the mechanical key stored in the electronic key.

Passive Entry and Start System

→ Refer to page 3-11

Tailgate



CAUTION

- Do not drive the vehicle with the tailgate open.

Tailgate Latch

Center handle model

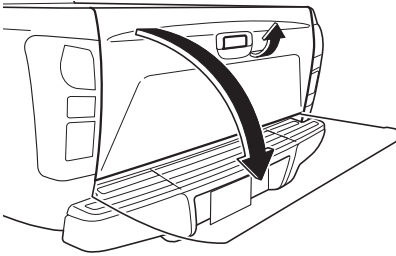

To Open

Pull the handle in the center of the tailgate and release the lock. Open the tailgate slowly.



NOTE

- The support stays will hold the tailgate open level.

Side handle model

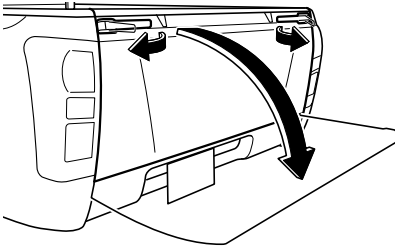

Pull the handle on both sides of the tailgate and release the lock. Open the tailgate slowly.



NOTE

- The support stays will hold the tailgate open level.

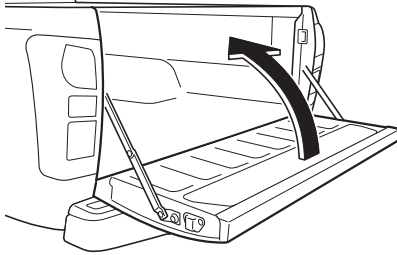
Center handle model**To Close**

Close the tailgate.

Move the tailgate back and forth to check that it is securely locked.

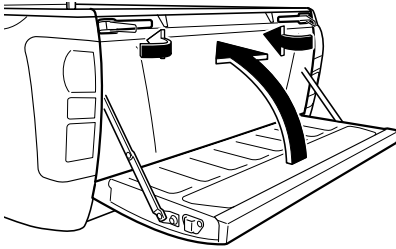
Side handle model

To close the tailgate, use the opening procedure in reverse.

Check that the lock is applied securely.

Tailgate Lock (with Key Lock)

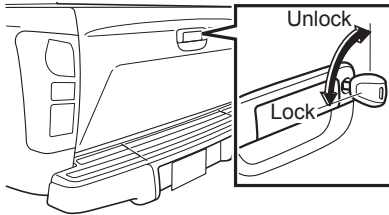

Firmly insert the key.

Turn it to the left to lock the tailgate. Turn it to the right to unlock the tailgate.

Rear Step Bumper

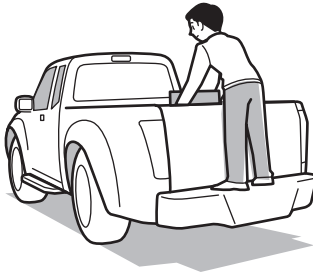

In models with a rear step bumper, use the rear step bumper for easy loading and unloading of cargo.

WARNING

- Do not allow more than one person at a time to step on the rear step bumper. The rear step bumper may be damaged.
- Do not move the vehicle when there is a person on the rear step bumper.
- Do not stand on the rear step bumper when the vehicle is moving.

Guard Frame Stopper

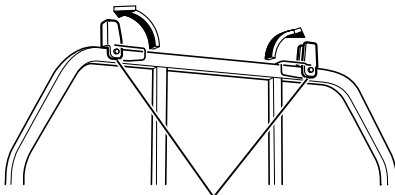

Guard frame stopper

When securing cargo to the guard frame, use the guard frame stopper to prevent these cargo from shifting. When using the guard frame stopper, lift it up to the outside of the vehicle.

CAUTION

- When securing cargo using the guard frame, do not apply excessive force.

Getting In and Out of the Vehicle

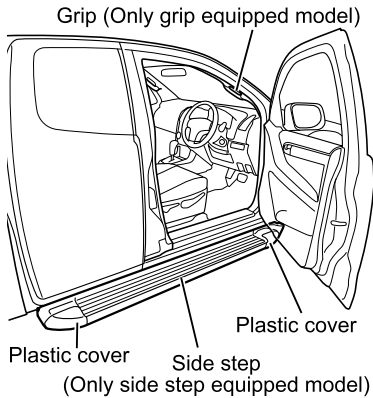

Carefully check that the area around the vehicle is safe, hold the grip if the vehicle model is equipped with grips, and when getting in or out of a side step equipped model, place your foot on the side step.



CAUTION

- When getting in or out of the vehicle, make sure you use the grip and step, etc. to always support yourself from at least 3 points. Furthermore, do not try to jump in or out of the vehicle, as doing so could cause unexpected accidents or injuries.
- In models with a side step, to avoid slipping over, do not step on the cover area (plastic cover).
- Getting in or out of the vehicle with oily or greasy hands or shoes could cause you to slip. Always thoroughly clean grease etc. from your hands and shoes before getting in or out of the vehicle.
- In models with a side step, rain and snow can cause the side step to become very slippery. Therefore, always remove snow and ice from your shoes and the side step, and be careful not to slip when getting in and out of the vehicle.
- Exercise caution when opening or closing doors, as strong winds or steep slopes may cause doors to open or close suddenly.



ADVICE

- Do not hold parts other than the grip when getting in or out of the vehicle. Doing so may cause damage to the vehicle or injuries to yourself or others.

Power Windows

The power windows operate only when the power mode is "ON" (models with passive entry and start system) or when the starter switch is in the "ON" position (models without passive entry and start system). Open each door window by pressing the power window switch; close each one by raising the switch.

WARNING

- Before closing the windows, make sure that there is no risk of a hand, head or anything else being trapped in the moving window. Failure to do so could result in serious injury. This is especially true when a child is with you.
- Do not allow children to operate the power window. A child may become trapped or stuck in the window and this could result in serious injury.

CAUTION

- When opening or closing the window, do not operate the driver side window switch and the window switch of another door in the opposite direction at the same time.
- After the window is fully open or closed, do not continue to operate the window switch in the same direction.

NOTE

- When the battery has been reconnected, perform the following initialization settings in order to operate the driver's power window properly.
 - Open the driver's window halfway. Pull up the driver's window switch to fully close the driver's window and then keep the switch in this position for 2 seconds.

Window Switches on Driver's Door



NOTE

- In models with an automatic close window function and passive entry and start system, or an automatic close window function and keyless entry system (radio remote control units for door-lock), the driver's window can be opened or closed using the window switches on the driver's door for approximately 40 seconds after the power mode is switched to a mode other than "ON" (models with passive entry and start system) or the starter switch is turned to a position other than the "ON" position (models without passive entry and start system). However, if the driver's door or passenger's door is opened, the window cannot be opened or closed, even within this 40-second period.

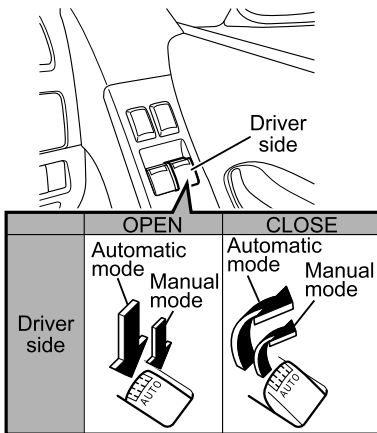

To Open the Driver's Window

Lightly pressing the driver side window switch will lower the driver's window until the switch is released (manual mode). When the switch is firmly pressed, the window will lower completely without the need to press the switch continuously (automatic mode). If you want to stop the automatic movement of the window before it lowers completely, raise the switch lightly.

To Close the Driver's Window



NOTE

- When a window is closed with automatic mode, if any foreign object is inserted between the window frame and the window, a jam protection function is equipped that will stop operation and open the window slightly to prevent objects becoming trapped.

Lightly raising the driver side window switch will cause the driver's window to move up until the switch is released (manual mode). When the switch is fully raised, the window will automatically rise to the completely closed position without the need to keep the switch continuously raised (automatic mode). If you want to stop the automatic movement of the window before it moves up completely, press the switch lightly.

WARNING

- Do not attempt to insert hand or place your head between the window and the window frame in order to ensure that the jam protection function operates properly. Failure to do so could result in serious injury.
- This function may not operate if an object becomes trapped just before the window fully closes. Also, the function will not operate if the window switch is continuously raised. Pay attention that your fingers do not become trapped. Failure to do so could result in serious injury.

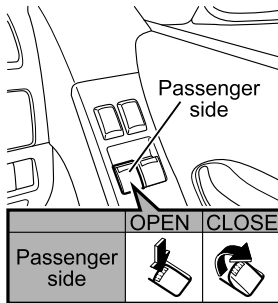
**To Open the Passenger's Window**

The passenger's window continues to lower while the passenger side switch on the driver's door is being pressed.

To Close the Passenger's Window

The passenger's window continues to move up while the passenger side switch on the driver's door is being raised.

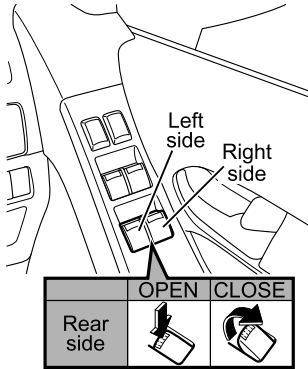

To Open a Rear Window (Crew Cab Model)

The rear window continues to lower while the rear side switch on the driver's door is being pressed.

To Close a Rear Window (Crew Cab Model)

The rear window continues to move up while the rear side switch on the driver's door is being raised.

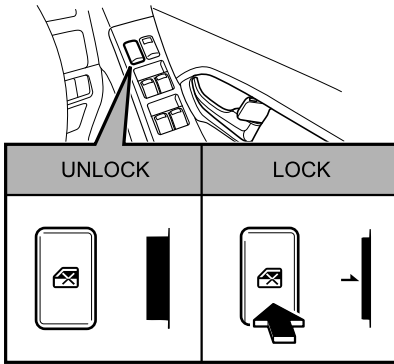

To Lock Passenger's Window and Rear Power Windows

If you push the power window lock switch, only the driver's window will be operable. To cancel the passenger's window and rear power windows (crew cab model) lock, push the switch again.

CAUTION

- Use the power window lock switch to lock the passenger's window and rear power windows (crew cab model) when carrying a child in the vehicle. By doing so, you can prevent the child from operating the passenger's window and rear power windows (crew cab model) and causing an accident.

Window Switches on Passenger's Door and Rear Doors

Passenger side

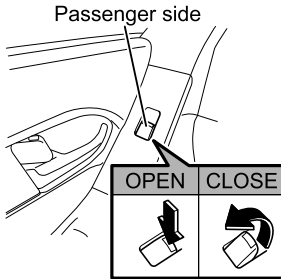

Window switch on rear doors (Crew cab model)

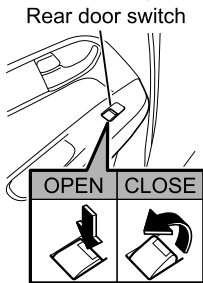

CAUTION

- Be sure to warn passengers, especially in the case of a child, not to let any part of the body become trapped or caught in a moving window.

The window continues to lower while the window switch is being pressed and continues to rise while the switch is being raised. It will stop moving at any position when the switch is released.

NOTE

- When the power window lock switch is in the "LOCK" position, it is not possible to open and close the passenger's window and rear windows.

Window Switches on Center of Instrument Panel

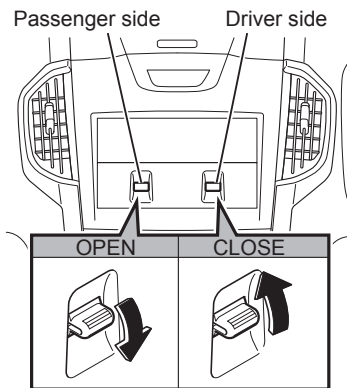

CAUTION

- Be sure to warn passengers, especially in the case of a child, not to let any part of the body become trapped or caught in a moving window.

The window continues to lower while the window switch is being pressed and continues to rise while the switch is being raised. It will stop moving at any position when the switch is released.

Manually Operated Windows



CAUTION

- Be sure that you and the passenger are at no risk of having any part of the body become trapped in the window. You should be especially careful if a child is with you.

Window Regulator Handle

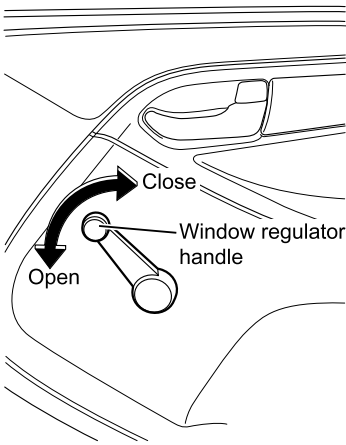

Turn the window regulator handle to open or close the window.

Quarter Window Opener (Extended Cab Model)

Quarter window opener

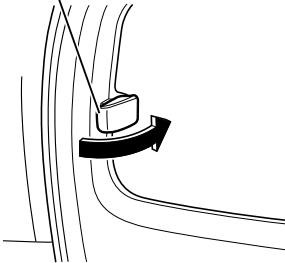

The quarter window on each side can be opened and closed by operating the quarter window opener.

Fuel Tank Filler Cap

WARNING

- Be sure to switch the power mode to "ACC" or "OFF" (models with passive entry and start system) or to turn the starter switch to the "ACC" or "LOCK" position (models without passive entry and start system) to stop the engine before refueling the vehicle. Refueling while the engine is running could cause a fire in your vehicle.
- Open the fuel tank filler cap slowly. If you open it quickly, the fuel tank pressure may cause fuel to spurt out.
- When refueling, never smoke or place any ignition source nearby. There is a risk of fire.
- After refueling, make sure that the fuel tank filler cap is tightly closed.
- Do not use any fuel tank filler cap that is not an Isuzu genuine part.
The use of an improper fuel tank filler cap could cause fuel spillage in the event of an accident. The use of an improper fuel tank filler cap could also affect the fuel system and the emission control system.
- Be sure to wipe off the fuel that is spilled at refueling.

CAUTION

- Be sure to use extra-low-sulfur diesel fuel (containing sulfur of 10 ppm or lower).
- The use of a poor-quality diesel fuel, mixing such an additive as water remover to the fuel in the tank, or filling the tank with gasoline, kerosene or an alcohol-based fuel or its mixture with a diesel fuel will badly affect the fuel filter and result in lubrication problems in fuel-lubricated components of the injectors. In addition, this practice can also impair the operation of the engine and the diesel particulate defuser (DPD), the exhaust emission cleaning system, possibly leading to breakdown of the engine-related systems. If an incorrect fuel should accidentally be added, drain all fuel from the system. Failure to observe this precaution can result in a fire or permanent damage when the engine is started.
- The use of any fuel other than an extra-low-sulfur diesel fuel may violate the relevant regulations enforced in certain countries or regions.

Using Self-service Filling Stations

→ Refer to page 2-5

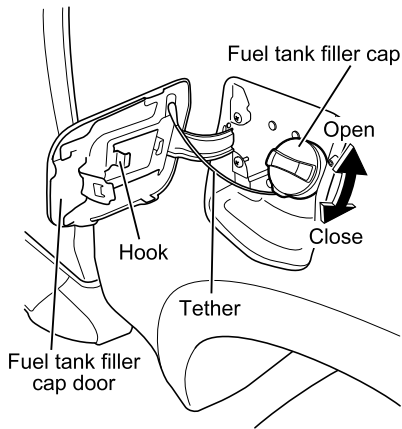
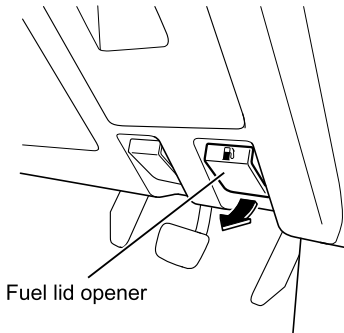

Opening and Closing the Fuel Tank Filler Cap (without Key Lock)

1. To open the fuel tank filler cap door on the cargo side, pull the fuel lid opener toward you.
2. Eliminate static electricity from your body before opening the fuel tank filler cap.
3. Slowly turn the cap counterclockwise to open it.
4. After removing the fuel tank filler cap, hang it on the hook.
5. Refuel the tank.
6. Turn the fuel tank filler cap clockwise until it clicks more than 3 times to install it securely.
7. Close the fuel tank filler cap door on the cargo side.



ADVICE

- If the fuel tank filler cap is not hung on the hook, the fuel tank filler cap may hit the body panel and the remaining fuel on the fuel tank filler cap may damage the body paint.
- Closing the fuel tank filler cap door while the tether is twisted abnormally may cause the tether to be damaged.



NOTE

- Allowable fuel type ("DIESEL") is shown at the fuel tank filler cap.

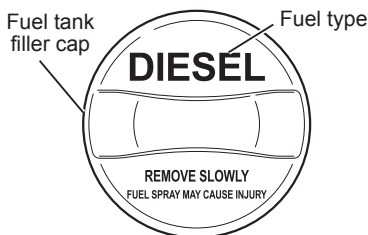

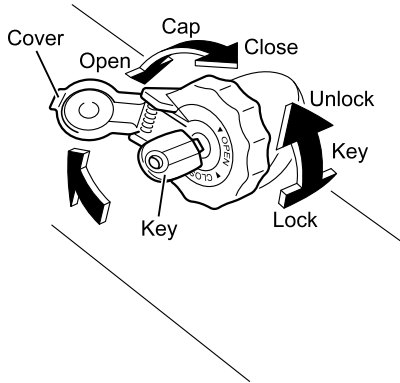

Opening and Closing the Fuel Tank Filler Cap (with Key Lock)

1. Eliminate static electricity from your body before opening the fuel tank filler cap.
2. Open the cover, then firmly insert the key and turn it to the "OPEN" position.
3. Slowly turn the cap counterclockwise to open it.
4. Refuel the tank.
5. Securely screw the fuel tank filler cap onto the fuel filler neck.
6. Turn the key to the "CLOSE" position to lock the fuel tank filler cap.
7. Pull the key out, then make sure the fuel tank filler cap is securely closed.

WARNING

- If the fuel tank filler cap is not tightly closed, leaking fuel could start a fire while driving.

ADVICE

- When opening or closing the fuel tank filler cap, be sure to grasp the fuel tank filler cap itself, not the key. If you try to turn the fuel tank filler cap using the key, you could damage the key.
- Wipe off the key to remove any dirt or dust, etc. after pulling it out.

NOTE

- Allowable fuel type ("DIESEL") is shown at the fuel tank filler cap.

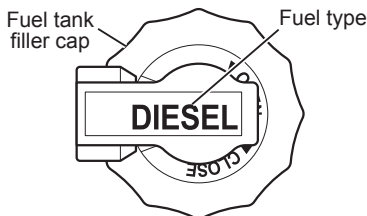

Seats

The driver's seat must be adjusted so that when you sit well back in the seat, you can fully depress the pedals without moving your back from the seatback, and you can operate the steering wheel easily and freely. After making adjustments, check that the seat is completely locked.

Adjusting the seat for a correct driving posture is a fundamental part of safe driving.

Make sure you can turn the steering wheel easily.



Make sure you can adequately press the pedals.



WARNING

- Use caution when adjusting the seat, as failure to do so could cause injury.
- Never allow children to adjust their seats themselves; an adult should adjust the seat for occupants who are children.
- Adjust the seat only before you start driving. Adjusting the seat while the vehicle is in motion must be avoided not only because the unlocked seat will move back and forth unstably, preventing you from taking the correct position, but might also cause you to lose control of the vehicle, possibly resulting in an accident.
- Try to move the seat without unlatching it after making adjustments to check that it is completely locked. A loosely locked seat may move unexpectedly and your position might then become unstable; this could lead to an accident. Take the vehicle to your Isuzu Dealer for service if you find that your seat adjusters do not latch. In addition, the seat belt will not operate properly if the seatback is not completely locked.
- Driving with the seat excessively reclined could be very dangerous in a collision or sudden stop. Raise the seatback, and wear the seat belt correctly while sitting well back and straight up in the seat.
- Do not place a cushion or similar object between your back and the seatback. Doing so not only affects the stability of your driving position but also prevents the seat belt from working effectively in the event of a collision.

WARNING (Continued)

WARNING (Continued)

- Do not place any objects under the seat. If there are any objects under the seat, the seat could be locked in an improper position.
- Before making adjustments, check that the seat rails are free of anything that could obstruct the locking of the seat. Be careful that hands and feet do not become trapped in the seat or rails when adjusting the seat and that the seat does not hit any objects or passengers while it is being adjusted.
- When you adjust the seat, be careful that the seat does not hit passengers or objects. Doing so could cause injury to passengers, or damage objects.

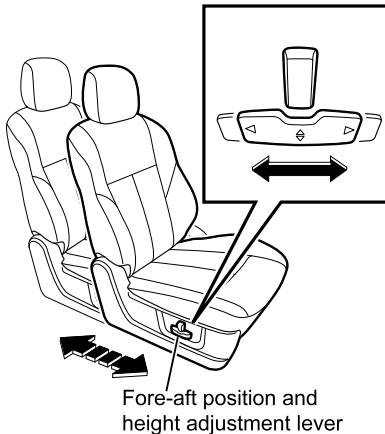
Driver's Seat**Forward/Backward Adjustment (Power Seat Model)**

When the lever is pushed forward, the seat will move forward. When it is pushed backward, the seat will move backward.

**ADVICE**

- The seat can be adjusted regardless of the power mode (models with passive entry and start system) or the position of the starter switch (models without passive entry and start system). However, adjusting it consumes a lot of electricity and could discharge the battery completely.

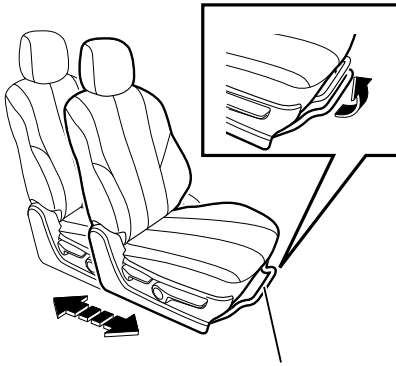

Fore-aft position adjustment lever

Forward/Backward Adjustment (Manual Seat Model)

While raising the lever, move the seat forward or backward. Release the lever when the seat is in the desired position. After making adjustments, try to move the seat back and forth to check that it is fully locked.

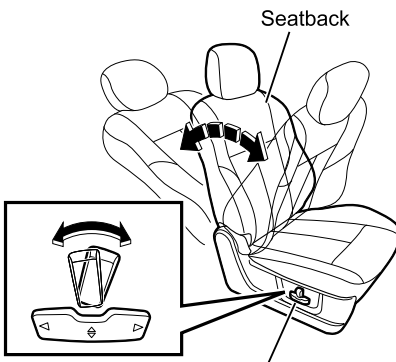

Seatback tilt lever

Reclining Adjustment (Power Seat Model)

When the seatback tilt lever is pushed forward, the seatback will tilt forward. When it is pushed backward, the seatback will tilt backward.



ADVICE

- The seat can be adjusted regardless of the power mode (models with passive entry and start system) or the position of the starter switch (models without passive entry and start system). However, adjusting it consumes a lot of electricity and could discharge the battery completely.

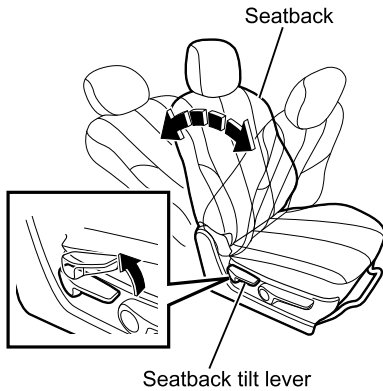

Reclining Adjustment (Manual Seat Model)

WARNING

- When reclining the seatback, hold the seatback with your hand while raising the seatback tilt lever. The seatback may suddenly move forward if it is not held with your hand, causing an injury. Once the seatback has returned to its original position, check that the seatback is fully locked by trying to rock it forward and backward.

To recline the seatback, raise the seatback tilt lever and gently lean back to the desired position.

To move the seatback forward, lean forward with your back slightly clear of the seatback and raise the lever. After making adjustments, check that the seatback is fully locked.



Height Adjustment (Power Seat Model)

When the rear side of the lever is pulled up, the seat will move up diagonally forward. When it is pushed down, the seat will move down diagonally backward.

ADVICE

- The seat can be adjusted regardless of the power mode (models with passive entry and start system) or the position of the starter switch (models without passive entry and start system). However, adjusting it consumes a lot of electricity and could discharge the battery completely.



Height Adjustment (Manual Seat Model)

When the height adjustment lever is repeatedly pulled up, the seat will move up diagonally forward. When it is repeatedly pushed down, the seat will move down diagonally backward. After making adjustments, check that the seat is fully locked.

Passenger Seat

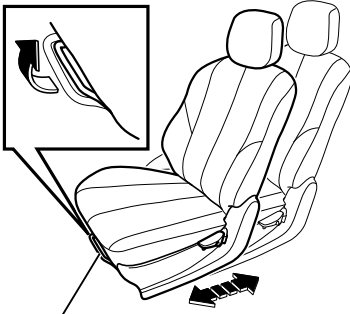

Fore-aft position adjustment lever

Forward/Backward Adjustment

While raising the lever, move the seat forward or backward. Release the lever when the seat is in the desired position. After making adjustments, try to move the seat back and forth to check that it is fully locked.

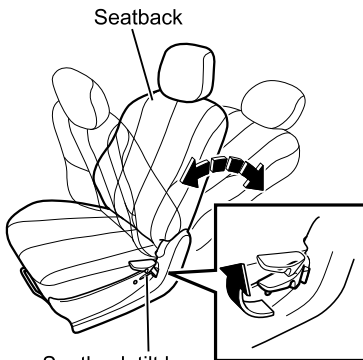

Seatback

Seatback tilt lever

Reclining Adjustment

WARNING

- When reclining the seatback, hold the seatback with your hand while raising the seatback tilt lever. The seatback may suddenly move forward if it is not held with your hand, causing an injury. Once the seatback has returned to its original position, check that the seatback is fully locked by trying to rock it forward and backward.

To recline the seatback, raise the seatback tilt lever and gently lean back to the desired position.

To move the seatback forward, lean forward with your back slightly clear of the seatback and raise the lever. After making adjustments, check that the seatback is fully locked.

Rear Seat

⚠ WARNING

- Do not place cargo higher than the seatback. Doing so may block the rear view and cargo may fly forward when suddenly applying the brakes.

Extended Cab Model**⚠ WARNING**

- Do not tip up the seat cushion while driving.
- When you tip up the seat cushion, tip up the seat cushion slowly.
- When you tip up the seat cushion or return it to the original position, be careful not to trap a hand or foot.

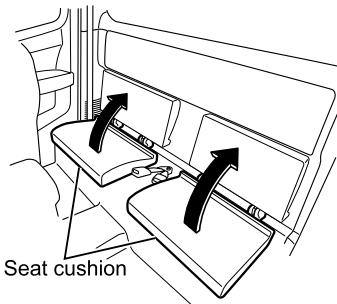

It is possible to tip up the seat cushion.

Crew Cab Model**⚠ WARNING**

- Do not move the seatback forward while driving.
- Do not sit on a folded seatback or place objects on it while driving.
- When folding the seatback forward, hold the seatback with your hand while pulling the strap up. The seatback may suddenly move forward if it is not held with your hand, causing an injury.
- When you fold the seatback forward, fold the seatback slowly while holding the seatback.
- When you fold the seatback forward, be careful that the seatback does not hit passengers or objects.
- When you return the seatback to the original position, try to move the seatback to check that it is completely locked. In addition, the seat belt will not operate properly if the seatback is not completely locked.
- When you fold the seatback forward or return it to the original position, be careful not to trap a hand or foot.

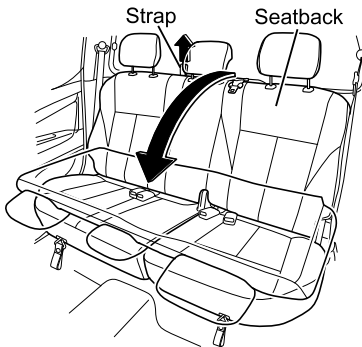

It is possible to fold the seatback forward by pulling the strap.

Before folding the seatback forward, retract the rear center seat belt.

After returning the seatback to the original position, connect the rear center seat belt.

**ADVICE**

- When you return the seatback to the original position, be careful not to trap the latch plate of the rear center seat belt between the rear seat and the panel behind the rear seats.

Rear Center Seat Belt

→ Refer to page 3-66

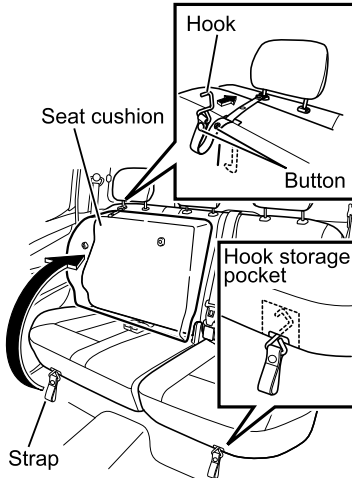

Pull the strap forward to raise the seat cushion. Remove the hook of the strap edge from the strap button and secure the hook to the headrest stay.

WARNING

- Do not raise the seat cushion while driving.
- When raising the seat cushion, the hook of seat cushion strap must be secured to the headrest stay to keep the seat cushion locked safely in the storage position.
- When returning the seat cushion to its original position, hold the seat cushion and slowly lay it down. Finally, try to move the seat cushion to check that it is completely locked.
- After returning the seat cushion to its original position, do not forget to return the hook to the hook storage pocket.
- When returning the seat cushion to its original position, make sure the seat belt does not get trapped. In addition, make sure the seat belt lays on top of the seat cushion after returning the seat cushion to its original position.

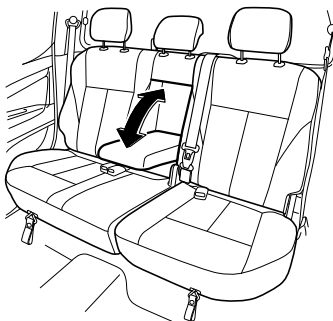

Center Armrest

In models with a center armrest, pull the armrest out from the seatback, then push it forward to use.

WARNING

- Before using the center armrest, fasten your seat belt.
- Do not sit on the center armrest or place heavy objects on it.

Headrest

WARNING

- Do not drive with a headrest removed. There is a chance that impacts to the head area would not be prevented and this could result in serious injury.
- Be sure to adjust the headrest before driving. If you adjust the headrest while the vehicle is in motion, you will be unable to maintain the correct driving posture. This may cause an accident.
- After making adjustments, try to move the headrest to check that it is completely locked.
- Use the appropriate headrest for each seat.

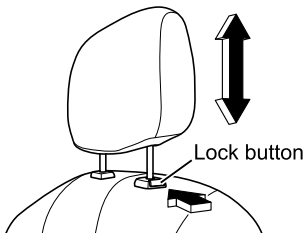

Driver and Passenger Seat

The driver and passenger seats have 4 adjustment levels. Make adjustments that align the center of your head to the center of the headrest. When raising it, lift it up in this position. When lowering it, push the lock button while pushing the headrest down.

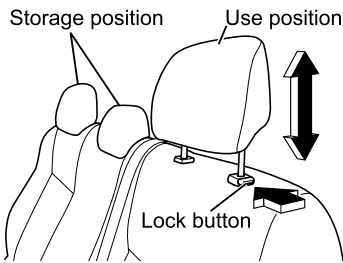

Rear Seat (Crew Cab Model)

The rear seat can only be changed between the use position and storage position. Always select the use position when riding in the vehicle. When selecting the use position, move the headrest to the securely locked position in which a clicking sound can be heard. When selecting the storage position, push the lock button while pushing the headrest down.

Installation and Removal

When pulling out or inserting a headrest, press the lock button.

Tilt Steering

The steering wheel is adjustable up and down.

WARNING

- When you have adjusted the steering wheel, try pulling the steering wheel up and down to check that it is securely locked in position before driving.
- Adjust the position of the steering wheel before you start driving. Adjusting the position of the steering wheel while driving would be extremely dangerous because the steering wheel would rattle up and down, preventing precise steering.

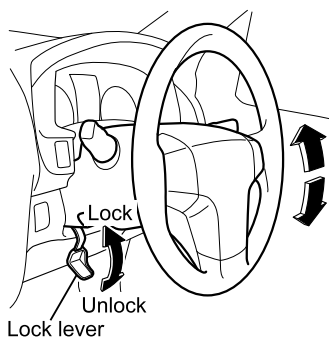

Adjustment

1. Lower the lock lever downward to unlock the steering column.
2. Sit in the correct driving position, and then move the steering wheel up and down to select the optimum steering wheel position.
3. Firmly lock the steering wheel at the selected position by moving the lock lever to the lock position.

Mirrors

Sit in the correct driving position on the properly adjusted seat, and then check each mirror to ensure that it provides a proper view of the rear, the sides, the area just in front of the vehicle, and the area directly opposite to the driver's seat. Make adjustments if necessary and clean any dirty mirrors.

Inside Rearview Mirror

WARNING

- Adjust the mirror when the vehicle is stationary, not while the vehicle is in motion.

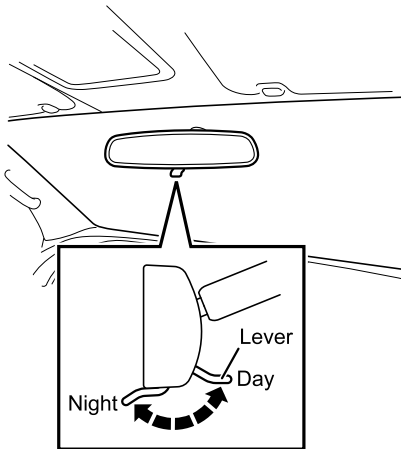

Normally, with the lever pushed toward the front of the vehicle, move the mirror to adjust to a position where it provides a proper rear view. When the headlights of vehicles behind you are reflected brightly when driving at night, pull the lever toward you. By doing this you can reduce the reflection.

WARNING

- Do not clean the rearview mirror glass with a cleaner containing ammonia or acetic acid. Doing so may result in damage to the mirror's coating.

Outside Rearview Mirrors

After properly adjusting your seat for proper driving position, adjust the mirrors indicated below so that they provide adequate views for checking the rear, the side and the areas just in front and immediately to the side of the vehicle by moving each of the mirrors.

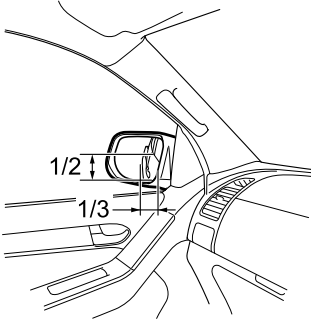

Lateral-direction: Adjust the mirror so that you can see the vehicle's side including the inner one-third of the mirror.

Vertical-direction: Adjust the mirror so that you see the rear bottom corner of the vehicle halfway up the height of the mirror.



WARNING

- Adjust the mirrors when the vehicle is stationary, not while the vehicle is in motion.
- Do not drive with the mirrors folded.



CAUTION

- When checking the rear of the vehicle with mirrors, be careful that this does not distract your attention from the traffic ahead.
- Rearview mirrors may make the vehicle behind you appear farther away than it really is. Use these mirrors very carefully until you are able to correctly determine distances from the images.
- Keep the mirrors in mind when passing another vehicle on a narrow road, moving the vehicle into a garage or driving near pedestrians.

Remote Control Mirror Switch

→ Refer to page 4-129

Seat Belts



The protection provided by seat belts might be significantly reduced if they are not fastened properly; in certain cases, improperly fastened seat belts can even play a role in causing injury to the wearer. Seat belts must be worn not only by the driver but also by the passenger(s) before the vehicle starts moving. You should be fully acquainted with the proper use of seat belts and important points to be respected as described in the following pages. Familiarizing yourself with the correct use of seat belts is essential for your safety.

WARNING

- Seat belts must always be fastened before starting to drive.
- Seat belts provide full protection only when the driver and passenger(s) fasten them while sitting upright and fully back on the seat.
- Wearing a seat belt with the seatback excessively reclined could be very dangerous in a collision or sudden stop since the occupant may slide under the belt and be seriously injured. Seat belts work best only when the occupant is sitting well back and straight up in the seat.
- Be sure to insert the latch plate into the buckle until a click is heard. An incompletely inserted latch plate is dangerous in the event of a collision or sudden stop.
- Do not run the seat belt over your face, chin or neck.
- Wear the seat belt as low as possible around the hips, not around the waist. A seat belt running over the waist would press the abdomen with a strong force and could increase the likelihood of injuries in a collision or sudden stop.
- Do not use a seat belt for a small child if the belt is on or very close to the child's neck or chin. Also, do not use a seat belt if it does not fit snugly over the child's hips because restraining the child under those conditions could be dangerous in the event of a collision or sudden stop. Instead, use an appropriate child restraint system (CRS) available on the market. For further details, please contact your Isuzu Dealer.
- Use a CRS that fits the size of the infant or child. Install the system according to the manufacturer's instructions.

WARNING (Continued)

WARNING (Continued)

- Remove any twists in the seat belt before fastening it. A seat belt with twists will not provide full protection because it cannot disperse shocks efficiently in the event of a collision or sudden stop.
- Too much slack could increase the amount of injury because the belt would not be able to properly restrain you in an accident.
- Expecting mothers or people suffering from chest or abdominal conditions should check with their doctor for specific recommendations about wearing seat belts.
- Do not use one seat belt for more than one person. If worn by more than one person, the seat belt would not work effectively in a collision or sudden stop.
- Have seat belts inspected and, if necessary, replaced by the nearest Isuzu Dealer when the webbing becomes frayed or worn and/or when the buckle or other mechanical parts fail to work properly.
- Do not disassemble the seat belts or modify the system.
- If your vehicle has been involved in a collision, the seat belts worn at the time may have lost their original strength due to impact even if they appear intact. These seat belts must be inspected and, if necessary, replaced by the nearest Isuzu Dealer.
- Be careful to keep the buckles and retractors free of dust and foreign matter.
- Wearing seat belts is a legal requirement. The driver is responsible not only for wearing a seat belt himself/herself but also for prompting all passengers to wear their seat belts. It is necessary, however, to check with a doctor about the appropriateness of a seat belt for an expecting mother or a passenger with a chest/abdominal condition.
- Regularly inspect to see if the seat belts, buckles, latch plates, retractors, and anchors function properly.
- Do not place objects near the seat belts if the objects could damage the seat belts.

Seats → Refer to page 3-48

Seat Belt Warning Light (Driver Seat)

→ Refer to page 4-70

Seat Belt Warning Light (Front Passenger Seat)

→ Refer to page 4-71

Seat Belt Care

→ Refer to page 6-119

Three-Point Seat Belts (ELR)

The seat belt extends or retracts freely if the wearer moves slowly, but it locks and restrains the occupant during forward force caused by the occupant's body following a strong shock. Adjust the driver's and passenger's shoulder belts for proper position by means of the shoulder anchor.

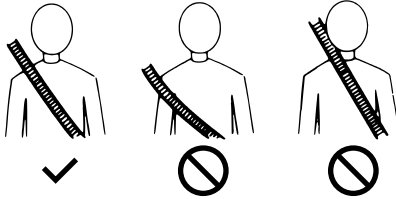

WARNING

- The shoulder belt should be adequately positioned on your shoulder but should not touch your neck and/or face. The shoulder belt could harm you in a collision or sudden stop if it is in contact with your neck and/or face.

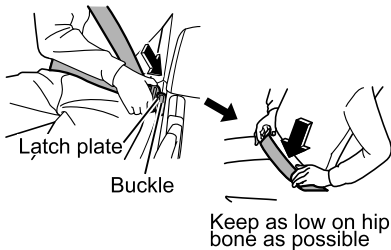

To Fasten

1. Sit on the seat in the correct driving position.
2. Pull out the seat belt holding the latch plate. After checking that there are no twists in the belt, insert the latch plate into the buckle until it clicks.
3. To reduce the risk of sliding under the belt during a collision, position the belt across your lap as low on your hips as possible and adjust it to a snug fit by pulling the shoulder portion upward through the latch plate.

The lap-shoulder belt is designed to lock during a sudden stop or impact. At other times it should move freely.

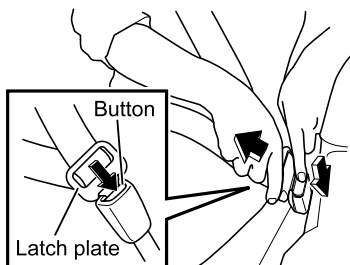

To Unfasten

Push the button on the buckle. As the belt automatically retracts, let it be taken up slowly by holding on to the latch plate until the belt is fully retracted.

CAUTION

- If you repair any components around the steering wheel, instrument panel, center console and brake/clutch pedal or the driver's and passenger's seat belts, or if you install an audio system or other equipment, the seat belt system with pretensioner and airbag system may be adversely affected, possibly causing the seat belt to suddenly retract or the airbag to suddenly deploy, which could result in injury. Be sure to have any repair or installation done by your Isuzu Dealer.

ADVICE

- While being automatically retracted, the seat belt could damage a nearby window or interior trim unless the latch plate is properly held. Hold the latch plate to ensure that the belt is taken up slowly.
- Before closing the door, check that the retracted seat belt is taut. A slack belt could become trapped in the door or seat rail.
- When the seat belt is fully taken up (or not pulled out), check that the stopper is holding the belt in a fully taut state.

**NOTE**

- For vehicles equipped with an airbag system, the driver's seat belt and the passenger's seat belt feature pretensioner and load limiter functions.
- The three-point seat belts are provided with an emergency locking retractor (ELR) function.

[ELR function]

- The ELR normally allows the seat belt to move in and out freely as the occupant moves. However, it locks the seat belt to restrain the occupant when a forward force resulting from a collision or sudden stop acts on the occupant.
- The ELR also locks the seat belt when the belt is pulled out quickly. If this happens, allow it to retract once and then pull it out slowly.

[Load limiter function]

- The load limiter allows the seat belt to extend while maintaining the load working on the belt at a constant level. This helps alleviate the shock applied on the occupant's chest.

Front Seat Belt with Pretensioner and SRS Airbag System

→ Refer to page 3-80

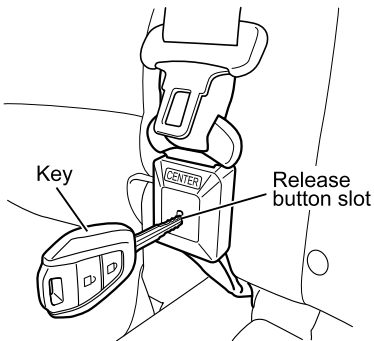
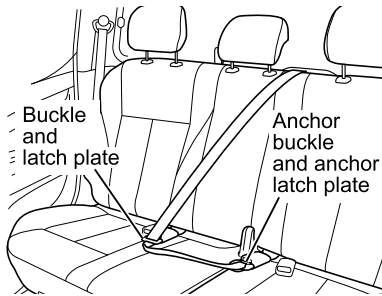

Rear Center Seat Belt

When using the rear center seat belt, make sure that each latch plate and buckle are securely locked.

When not using the rear center seat belt, connect the anchor buckle and anchor latch plate. (Do not retract the seat belt.)

When you fold the seatback forward, retract the seat belt.

To retract the rear center seat belt, insert the key into the release button slot on the anchor buckle and disconnect the anchor buckle and anchor latch plate. As the belt automatically retracts, let it be taken up slowly by holding on to the anchor latch plate until the belt is fully retracted.



ADVICE

- While being automatically retracted, the seat belt could damage a nearby window or interior trim unless the latch plate is properly held. Hold the latch plate to ensure that the belt is taken up slowly.

To connect the rear center seat belt, pull out the seat belt holding the anchor latch plate. After checking that there are no twists in the belt, insert the anchor latch plate into the anchor buckle until it clicks.

**NOTE**

- In models with a passive entry and start system, use the mechanical key stored in the electronic key.

[Rear center seat belt design to prevent incorrect fastening]

- The rear center seat belt is designed so that it cannot be connected with any of the window-side seat belts.

In addition, the buckle of the rear center seat belt is identified by a "CENTER" mark to prevent incorrect fastening of the rear center seat belt.

Passive Entry and Start System

→ Refer to page 3-11

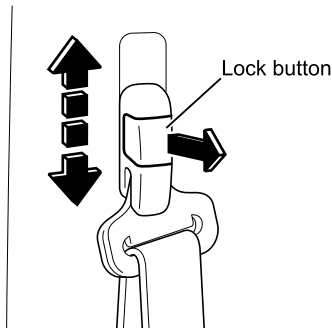
Shoulder Anchor (Front Seat Belt)**Adjustment**

Adjust the height of the shoulder anchor on the driver's door side and passenger's door side according to your body size. There are 4 adjustment positions.

To adjust the anchor height, move the shoulder anchor up or down with the lock button pulled toward you. When the desired height is achieved, release the lock button to lock it.

**CAUTION**

- Never adjust the shoulder anchor height while the vehicle is in motion. Doing this is very dangerous.
- The effectiveness of the seat belt will be reduced if it is not properly fastened. The shoulder anchor should be adjusted to a position as high as possible where the belt fits right on the shoulder but does not come in contact with your neck or face.
- After making adjustments, check that the shoulder anchor is completely locked.

Child Restraint System (CRS)

If you are travelling with children in the vehicle, CRS are required.

Tips for Selecting a CRS

Children should be restrained at all times and fitted with a CRS appropriate to their size when travelling in a vehicle. Following are some guidelines about selecting the appropriate restraint for your child.

WARNING

- Carefully follow the instructions in the CRS manufacturer's instruction manual to install the CRS.
- Make sure that installation is performed in compliance with all installation instructions provided by the CRS manufacturer and make sure that the system is secured properly. Improper installation may result in death or serious injuries to the child in event of sudden stopping or accidents.
- It is not recommended to use a CRS with tether strap for the vehicles without the top tether anchorage. When using the CRS with the tether strap, be sure to fix a tether strap to the top tether anchorage.

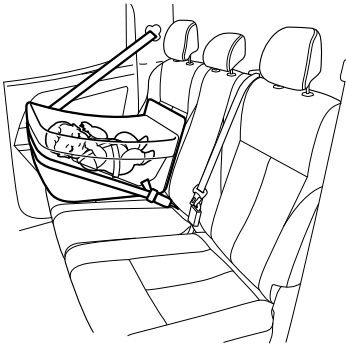

Infants

This type of CRS is designed so that in the event of a collision, impact forces will be evenly spread over the baby's back, with minimal jarring to the vulnerable head and neck area.

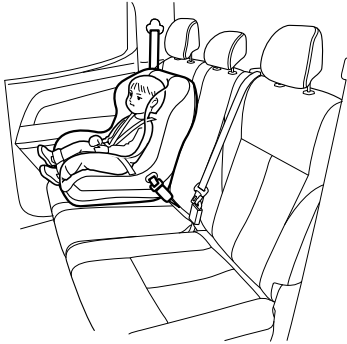

Young Children

This type of CRS is designed for use when the child is able to sit and easily hold his or her head upright. It is also possible to purchase convertible seats which can be used as a rear-facing infant restraint or converted to a front-facing CRS.



Use this type of restraint system when children outgrow a typical front-facing CRS but they are still too small for lap/sash seat belts. A booster seat raises the child so that the knees bend comfortably, the lap /sash seat belt is correctly positioned and the child can see out the window. A rigid booster seat with a back, side wings and sash guide gives the best protection. In assessing the range of children who would benefit from booster seats, height is a better indicator than age or weight.

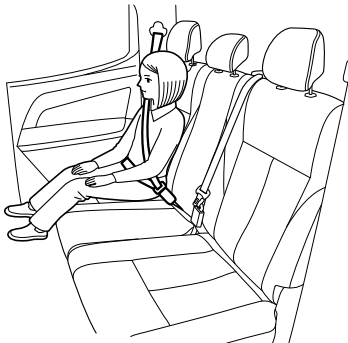

Older Children

A child should use a normal lap/sash seat belt only when:

- He/she can sit against the back of the rear seat with knees bent comfortably at the edge of the seat,
- Lap belt rests low and snug across the hips - not across the stomach,
- Sash belt is centered on shoulder and chest,
- He/she is able to stay seated like this for the entire trip.

**WARNING**

- Never insert coins, clips or other foreign objects into the buckle of your child's seat belt since this may cause improper latching of the latch plate and buckle.
- Do not use a defective seat belt. Immediately contact your Isuzu Dealer and repair the seat belt that does not function normally. You, your passengers and especially your child are at risk of death or serious injury when using a seat with a defective seat belt.
- Following the insertion of the latch plate into the buckle, make sure the latch plate and buckle are surely locked together, and that there is not twisting of the lap and shoulder portions of the seat belt.
- The seat belt cannot protect your child from death or serious injuries when it is defective. Immediately contact your Isuzu Dealer and repair the seat belt that does not function normally. Never use the CRS with the defective seat belt until it is fixed.
- For your child's safety, never place your child's armpit over the shoulder belt.

Children should be restrained at all times when travelling in a vehicle.

If a child cannot see out of the window, do not raise the child by means of an ordinary cushion. The cushion will not stay in place in the event of a crash, and the child would slip out of the straps and become entangled. Ensure that the seat belt fits firmly around the CRS.

WARNING

- Never use a rearward-facing CRS on a seat protected by an active airbag in front of it, death or serious injury to the child can occur.
- CRS anchorages are designed to withstand only those loads imposed by correctly fitted CRS. Under no circumstances are they to be used for adult seat belts, harnesses or for attaching other items or equipment to the vehicle.
- If using an ISO-FIX anchorage (lower anchorage and top tether anchorage), check whether your ISO-FIX CRS is a product that has received UN R44 (ECE R44) certification. Carefully follow the instructions in the CRS manufacturer's instruction manual to install the CRS.
- Where legally allowable, you may install a forward-facing CRS in the front seat, but always move the passenger's seat as far back as it will go.
- Make sure that the CRS is secured by pushing and pulling it in different directions. Install the system according to all installation instructions provided by its manufacturer.
- If the seat headrest interferes with the CRS, either remove the headrest or adjust it to a position where it does not interfere with the CRS.
- When CRS is not in use:
 - Make sure that the CRS is properly secured to the seat when it is not in use. Do not simply place a CRS on the seat without it being secured to the seat.

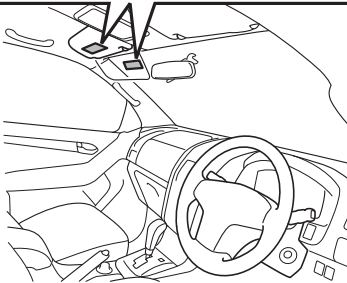
**NOTE**

- Models for the European and Turkey markets have a label on the passenger side sun visor that shows warning pictograms. Details of the label are shown in the figure.

Suitability for CRS

Regular Cab Model

Mass group		Seating position	
		Front passenger	
		With SRS airbag	
0	Up to 10 kg (22 lb)	X	
0+	Up to 13 kg (29 lb)	X	
I	9 to 18 kg (20 to 40 lb)	UF	
II	15 to 25 kg (33 to 55 lb)	UF	
III	22 to 36 kg (49 to 79 lb)	UF	

UF: Suitable for "Forward-facing universal" category restraints approved for use in this mass group.

X: Seat position not suitable for children in this mass group.

Extended Cab Model

Mass group		Seating position	
		Front passenger	Rear outboard
		With SRS airbag	
0	Up to 10 kg (22 lb)	X	X
0+	Up to 13 kg (29 lb)	X	X
I	9 to 18 kg (20 to 40 lb)	UF	X
II	15 to 25 kg (33 to 55 lb)	UF	X
III	22 to 36 kg (49 to 79 lb)	UF	X

UF: Suitable for "Forward-facing universal" category restraints approved for use in this mass group.

X: Seat position not suitable for children in this mass group.

Crew Cab Model

Mass group		Seating position		
		Front passenger	Rear outboard	Rear center
		With SRS airbag		
0	Up to 10 kg (22 lb)	X	U	U
0+	Up to 13 kg (29 lb)	X	U	U
I	9 to 18 kg (20 to 40 lb)	UF	U	U
II	15 to 25 kg (33 to 55 lb)	UF	U	U
III	22 to 36 kg (49 to 79 lb)	UF	U	U

U: Suitable for "Universal" category restraints approved for use in this mass group.

UF: Suitable for "Forward-facing universal" category restraints approved for use in this mass group.

X: Seat position not suitable for children in this mass group.

Suitability for ISO-FIX CRS

Body style	Mass group kg/lb	Size class	Fixture	ISO-FIX position	
					Rear out board
Crew cab	Carry-cot	F	ISO/L1		X
		G	ISO/L2		X
	0 - up to 10 kg / 22.1 lb	E	ISO/R1		IL
		E	ISO/R1		IL
	0+ - up to 13 kg / 28.7 lb	D	ISO/R2		IL
		C	ISO/R3		IL *1
		D	ISO/R2		IL
	I - 9 to 18 kg / 19.8 to 39.7 lb	C	ISO/R3		IL *1
		B	ISO/F2		IUF
		B1	ISO/F2X		IUF
		A	ISO/F3		IUF, IL *2
	II - 15 to 25 kg / 33.1 to 55.1 lb	—	(1)		X
	III - 22 to 36 kg / 48.5 to 79.4 lb	—	(1)		X

(1): For the CRS which do not carry the size class identification (A to G), please contact to the CRS manufacturer or dealer for handling the ISO-FIX CRS.

IUF: Suitable for ISO-FIX forward CRS of universal category approved for use in the mass group.

IL: Suitable for particular ISO-FIX CRS given in the attached list. These ISO-FIX CRS are those of the "specific vehicle", "restricted" or "semi-universal" categories.

X: ISO-FIX position not suitable for ISO-FIX CRS in this mass group and / or this size class.

*1: Fair G 0/1 S with ISO-FIX platform type D RWF (Rearward-facing)

*2: Fair G 0/1 S with ISO-FIX platform type D FWF (Forward-facing)

CRS Lower and Top Tether Anchorages

Except front seat and rear center seat are equipped with anchorages for securing the ISO-FIX CRS.



WARNING

- Child restraint anchorages are designed to withstand only those loads imposed by correctly fitted child restraints. Under no circumstances are they to be used for adult seat belts, harnesses, or for attaching other items or equipment to the vehicle.



NOTE

- When you buy an ISO-FIX CRS, contact your Isuzu Dealer and to get recommendation.
- Carefully follow the instructions in the CRS manufacturer's instruction manual to install the CRS.

To assist you in locating the lower anchorages for CRS, each seating position with the anchorage has a button on the seatback at each lower anchorage location.

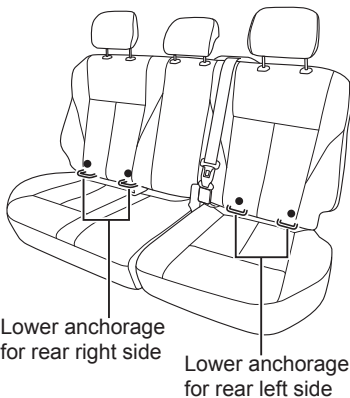

CRS lower anchorages are installed to the outboard seating positions.

Top tether anchorage

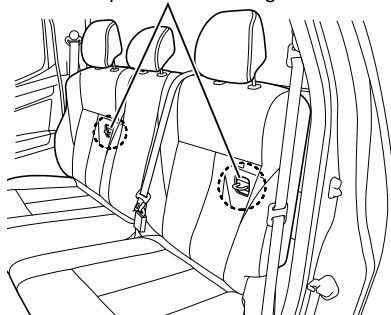

Top tether anchorages are installed on the panel behind the rear seats.

**NOTE**

- Top tether anchorages are not equipped on models for the Hong Kong market.

Installation Procedure

Top tether equipped CRS

Procedure No. 1) → 8)

Top tether not equipped CRS

Procedure No. 7)

1. Retract the rear center seat belt.
2. Adjust the head restraint to the use position.
3. Release the lock of seatback by pulling the strap and tilt the seatback forward.

Headrest Strap

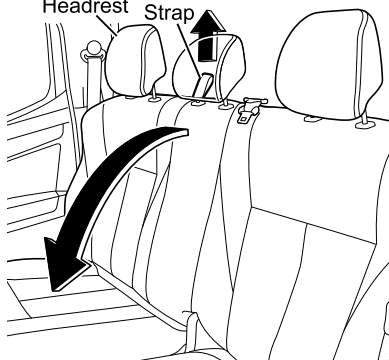

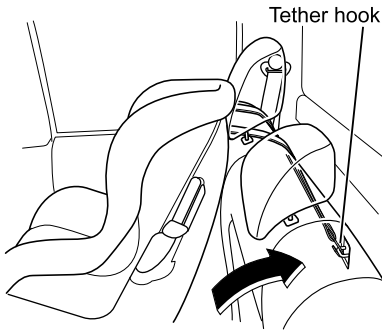

4. Attach the tether hook to the top tether anchorage.

WARNING

- When installing the CRS, if the headrest interferes with the top tether, remove the headrest.

Headrest → Refer to page 3-57

5. Return the seatback to the original position.

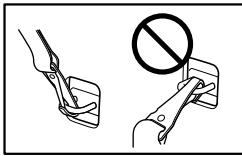

NOTE

- The seatback must be locked firmly to the back panel. Keep the tether strap and hook in an upwards direction.

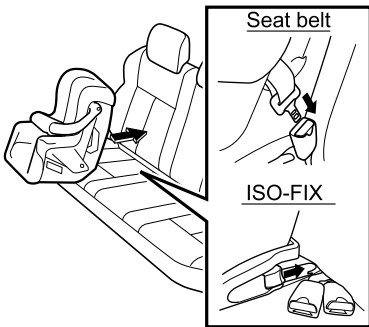
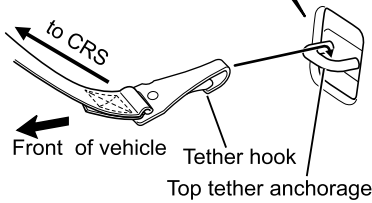

6. Connect the rear center seat belt.
7. Attach the CRS to the seat belt or both the ISO-FIX anchorages. Refer to the instruction manual of the CRS.

NOTE

- CRS must firmly attached and locked with seat belt or ISO-FIX anchorages.

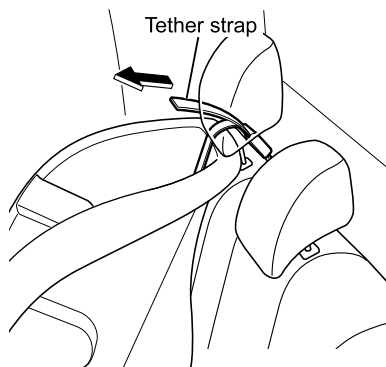

8. Adjust the tether strap length until it is attached tightly with the seat structure.

Uninstallation Procedure

Top tether equipped CRS

Procedure No. 1) → 8)

Top tether not equipped CRS

Procedure No. 1)

1. Release the CRS lock for the seat belt or the ISO-FIX anchorages.
2. Retract the rear center seat belt.

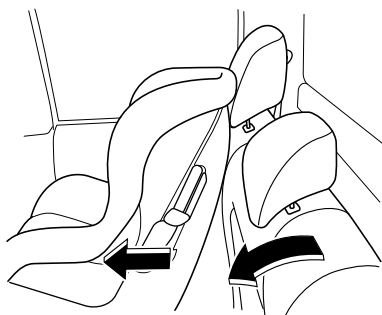
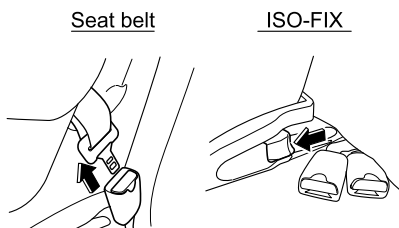

3. Release the lock of the seatback.
4. Tilt the seatback while moving the CRS forward.

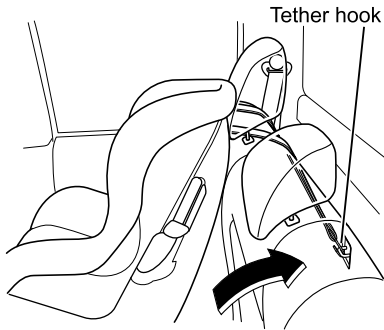

5. Loosen the CRS tether strap.
6. Remove the tether hook from the top tether anchorage.
7. Push and lock the seatback to the original position.
8. Connect the rear center seat belt.

**NOTE**

- The seatback must be locked firmly to the back panel.

Front Seat Belt with Pretensioner and SRS Airbag System

The front seat belt with pretensioner and supplemental restraint system (SRS) airbag system is activated in the event of a frontal collision when the impact energy exceeds a certain level to help mitigate the shock on the head of the driver and the passenger by firmly restraining the body of the occupant in the seat with the front seat belt with pretensioner and front airbag. In addition, in models with side airbag and curtain airbag, the front seat belt with pretensioner, side airbag and curtain airbag are activated in the event of a lateral collision when the impact energy exceeds a certain level to help mitigate the shock on the head and chest of the driver and the passenger by firmly restraining the body of the occupant in the seat, and the curtain airbag is activated to mitigate the shock on the head of the occupant sitting in the outboard seats of the models with the rear seat.

Be sure to observe the following instructions to prevent you and your passenger from suffering a serious or fatal injury due to impacts resulting from the front seat belt with pretensioner and airbag operation.

Operation Check

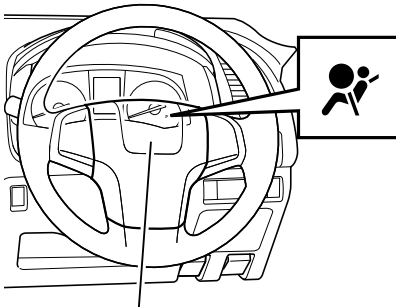

Airbag assembly for driver seat

The SRS airbag warning light checks and alerts the conditions of the SRS airbag system.

The SRS airbag warning light should flash seven times when the power mode is switched to "ON" (models with passive entry and start system) or when the starter switch is turned to the "ON" position (models without passive entry and start system), and should then go out.

If the SRS airbag warning light stays on, the airbag(s) may not function properly when needed. Drive the vehicle after the warning light goes out.

 **WARNING**

- If you encounter any of the following conditions, errors have occurred. Have your vehicle inspected/serviced at your Isuzu Dealer as soon as possible.
[System error]
 - If the SRS airbag warning light does not flash seven times when the power mode is switched to "ON" (models with passive entry and start system) or when the starter switch is turned to the "ON" position (models without passive entry and start system).
 - If the SRS airbag warning light does not go out.
 - If the SRS airbag warning light comes on while driving the vehicle.
- If you make unauthorized modifications to the vehicle or install an unauthorized accessory, the front seat belt with pretensioner and airbag may not operate correctly.
- If the steering wheel is changed to a non-standard one or a sticker is attached to the steering wheel pad, there could be a danger of system malfunction or the sticker flying off in the event of system activation. Attaching stickers or placing such things as accessories or air fresheners on the top surface of the instrument panel is also dangerous. They may prevent normal operation of the airbag or could fly off in the event of system activation.
- In models with side airbag and curtain airbag, do not attach seat covers under any circumstances. If a seat cover is attached or objects are placed in the area in which the side airbag inflates, the side airbag will not function correctly. Also, there could be a danger of objects flying off in the event of the system activation. In addition, if hard objects such as hangers or accessories are attached to the grip or coat hook, they may prevent normal operation of the curtain airbag and could fly off in the event of system activation.
- Do not apply excessive force to nor strongly hit the airbag installation area or the base of the b-pillar. Doing so may result in erroneous activation of the airbag or the front seat belt with pretensioner.

WARNING (Continued)

WARNING (Continued)

- Doing any of the following may require special precautions. Be sure to consult your Isuzu Dealer before doing any of the following. Failure to do so may cause the front seat belt with pretensioner and airbag to be unduly activated, causing the seat belt to be unexpectedly retracted or the airbag to be suddenly inflated, causing an injury to the occupant. Doing any of them improperly will adversely affect the operation of the system, causing a malfunction or failure.
 - Repair or replacement of the steering wheel, instrument panel, center console, parts around the accelerator pedal, front seat (in models with side airbag and curtain airbag), parts around the roof side (in models with side airbag and curtain airbag), and parts around the base of the b-pillar.
 - Repair, replacement or disposal of the front seat belt with pretensioner and airbag, or scrapping of a model that has front seat belt with pretensioner and airbag.
 - When audio equipment and accessories are installed or modification such as body mounting is carried out.
 - Making modifications to the front of the vehicle (bumper, frame, etc.), installing equipment (snow plows, etc.), making modifications to the frame, or making changes to the vehicle's height using unauthorized methods and/or materials.
 - Repairing or painting of panels at the front of the vehicle or panels on the cab.

**CAUTION**

Have your vehicle inspected at the nearest Isuzu Dealer promptly if you encounter any of the following conditions.

- The SRS airbag warning light shows an abnormality.
- The front seat belt with pretensioner and airbag are activated by an impact. (The SRS airbag warning light comes on.)
- Your vehicle has received a certain level of frontal impact, or lateral impact (in models with side airbag and curtain airbag), even when the impact has not activated the front seat belt with pretensioner and airbag.
- The seat belt is frayed or worn out.
- The steering pad surface and instrument panel surface is cracked or otherwise damaged, or it receives an impact.
- In models with side airbag and curtain airbag, when the surface of the airbag storage of the front seat or surface of the airbag storage of the roof side is cracked or otherwise damaged, or it receives an impact.

SRS Airbag Warning Light

→ Refer to page 4-72

Front Seat Belt with Pretensioner

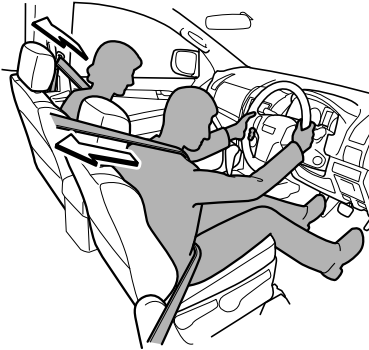

When the vehicle receives an impact exceeding a certain level during a frontal collision, or lateral collision (in models with side airbag and curtain airbag), the fastened seat belt is retracted instantly and removes the slack in the seat belt to securely restrain the driver and the passenger in the seat, thus enhancing the seat belt's restraining effect.

Seat Belts → Refer to page 3-61

WARNING

- The front seat belt with pretensioner helps reduce the risk of a serious injury to the driver and the passenger should the vehicle receive a frontal impact, or lateral impact (in models with side airbag and curtain airbag), exceeding a certain level. The maximum effect is achieved only if the seat belt is correctly worn.
- The front seat belt with pretensioner takes up the slack in the seat belt instantly to help reduce the risk of a serious injury. If the front seat belt with pretensioner activates, you may suffer scratches or a slight bruise or burn due to heat generated by rubbing.

CAUTION

- Do not remove or disassemble the seat belt. Accidental activation of the system may cause parts to fly off, causing an injury to you; or causing malfunction.

ADVICE

- Once activated during a collision, the front seat belt with pretensioner cannot be reused. The seat belt must be replaced immediately at the nearest Isuzu Dealer.

**NOTE**

- Even if the pretensioner function fails, the seat belt still operate as a regular seat belt (with ELR) and the seat belt function is ensured.
- The pretensioner generates a sound at the moment it retracts the seat belt.
- When the front seat belt with pretensioner and airbag system are activated by an impact, the SRS airbag warning light comes on.

Supplemental Restraint System (SRS) Airbag

Front SRS Airbag

The front SRS airbag inflates in the event of a frontal collision with the impact exceeding a certain level and helps to disperse and reduce the impact on the body of the driver and the passenger as a supplement to the front seat belt with pretensioner.

WARNING

- The front airbag supplements the occupant protection effect of the seat belt by being activated together with the front seat belt with pretensioner to reduce severity of injury to the driver and the passenger should the vehicle receive a frontal impact exceeding a certain level. The maximum effect is achieved only if the seat belt is correctly worn.
- The front airbag does not replace the seat belt. Be sure to wear the seat belt.
- The front airbag is instantly inflated with considerable force to reduce serious injury. If the airbag inflates, you may suffer scratches or a slight bruise or burn due to heat generated by rubbing.
- When the vehicle receives an impact exceeding a certain level, resulting in front airbag deployment, deformation of the vehicle may cause the windshield to break.
- Activation of the passenger SRS airbag may cause damage to the windshield.
- The front airbag cannot be reused once it is inflated. Immediately replace it at the nearest Isuzu Dealer.

ADVICE

- When the front airbag is inflated, a sound and white smoke are produced but this is not the result of a fire. This white smoke is not detrimental your health. However, if residue (gas and so on) adheres to your eyes and skin, rinse them with water as soon as possible. Although it is rare, a person with delicate skin may suffer from irritation.
- Immediately after the front airbag is inflated, the metal portion that inflates the airbag gets hot. Do not touch it.

**NOTE**

- The front airbag is quickly deflated after deployment and does not hinder visibility.
- When the front seat belt with pretensioner and front airbag are activated by an impact, the SRS airbag warning light comes on.
- In models with side airbag and curtain airbag, the front airbag is activated independently from the side airbag and curtain airbag. When the front airbag is activated, the front seat belt with the pretensioner is also activated at the same time.

Side SRS Airbag and Curtain SRS Airbag

The side SRS airbag and curtain SRS airbag inflate in the event of a lateral collision with the impact exceeding a certain level and helps to disperse and reduce the impact on the body of the driver and the passenger (and the occupant sitting in the outboard rear seats of the models with the rear seat as a supplement) to the front seat belt with pretensioner.

**WARNING**

- The side airbag and curtain airbag supplement the occupant protection effect of the seat belt by being activated together with the front seat belt with pretensioner to reduce severity of injury to the driver and the passenger and the occupant sitting in the outboard rear seats of the models with the rear seat should the vehicle receive a lateral impact exceeding a certain level. The maximum effect is achieved only if the seat belt is correctly worn.
- The side airbag and curtain airbag do not replace the seat belt. Be sure to wear the seat belt.
- The side airbag and curtain airbag are instantly inflated with considerable force to reduce serious injury. If the airbag inflates, you may suffer scratches or a slight bruise or burn due to heat generated by rubbing.
- When the vehicle receives an impact exceeding a certain level, resulting in side airbag and curtain airbag deployment, deformation of the vehicle may cause the windshield to break.
- The side airbag and curtain airbag cannot be reused once it is inflated. Immediately replace it at the nearest Isuzu Dealer.

**ADVICE**

- When the side airbag and curtain airbag are inflated, a sound and white smoke are produced but this is not the result of a fire. This white smoke is not detrimental your health. However, if residue (gas and so on) adheres to your eyes and skin, rinse them with water as soon as possible. Although it is rare, a person with delicate skin may suffer from irritation.
- Immediately after the side airbag and curtain airbag are inflated, the metal portion that inflates the airbag gets hot. Do not touch it.

**NOTE**

- When the front seat belt with pretensioner, side airbag and curtain airbag are activated by an impact, the SRS airbag warning light comes on.
- The side airbag and curtain airbag are activated independently from the front airbag. When the side airbag and curtain airbag are activated, the front seat belt with the pretensioner is also activated at the same time.

When and How the Front Seat Belt with Pretensioner and SRS Airbag System Operates

The front seat belt with pretensioner and airbag system are activated when the vehicle receives an impact exceeding a certain level in the event of a frontal collision, or lateral collision (in models with side airbag and curtain airbag). Because the vehicle body absorbs part of impact energy, the system may not be activated due to reduction in the force of the impact or the intensity or direction of the impact received. However, even if the front of the vehicle is largely deformed by the collision, in some cases the impact on the seat is not severe. Therefore, the severity of deformation of and damage to the vehicle do not necessarily coincide with the activation of the airbag.

When are the Front Seat Belt with Pretensioner and Front SRS Airbag System Activated?

When the vehicle collides head-on against a parked/stopped vehicle or a moving vehicle with an impact of a certain level or higher



When the vehicle collides head-on against a solid wall with an impact of a certain level or higher



WARNING

- Immediately after the front airbag is inflated, the metal portion that inflates the airbag gets hot. Do not touch it. Doing so may cause a serious injury such as a burn.

NOTE

- The passenger side front SRS airbag may activate even if a passenger is not present.

When the vehicle is hit from the side with an impact of a certain level or higher

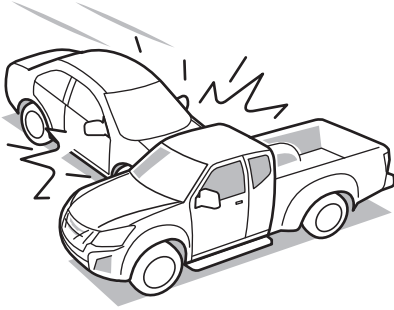

When are the Front Seat Belt with Pretensioner, Side SRS Airbag and Curtain SRS Airbag System Activated?

 **WARNING**

- Immediately after the side airbag and curtain airbag are inflated, the metal portion that inflates the airbag gets hot. Do not touch it. Doing so may cause a serious injury such as a burn.

 **NOTE**

- The passenger side side SRS airbag and curtain SRS airbag may activate even if a passenger is not present.

When are the Front Seat Belt with Pretensioner and Front SRS Airbag System not Likely to Be Activated?

In the following cases, the front seat belt with pretensioner and front SRS airbag system are less likely to be activated even if they are working properly.

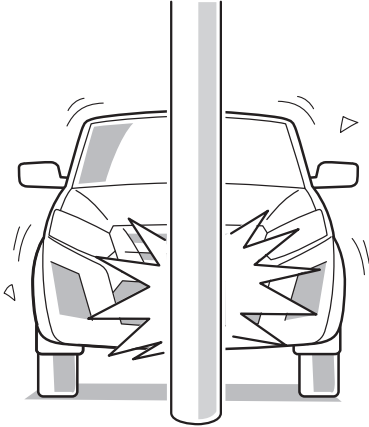
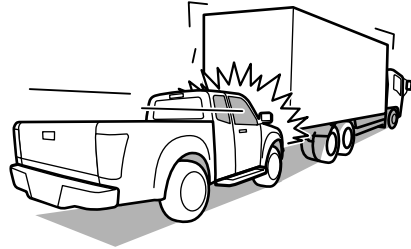
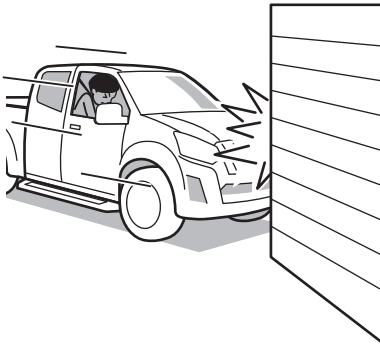
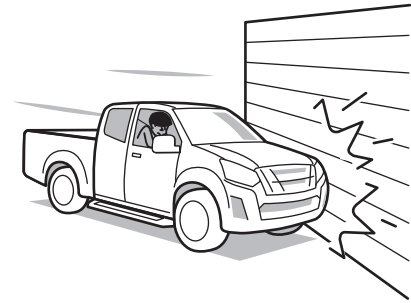
When the vehicle collides against a utility pole or standing tree**When the vehicle gets under a vehicle or obstacle****When the vehicle has an offset collision (one-sided collision)****When the vehicle has a frontal angle collision**

When are the Front Seat Belt with Pretensioner, Side SRS Airbag and Curtain SRS Airbag System Not Likely to Be Activated?

In the following cases, the front seat belt with pretensioner, side SRS airbag and curtain SRS airbag system are less likely to be activated even if they are working properly.

When the vehicle collides against a utility pole or standing tree from the side

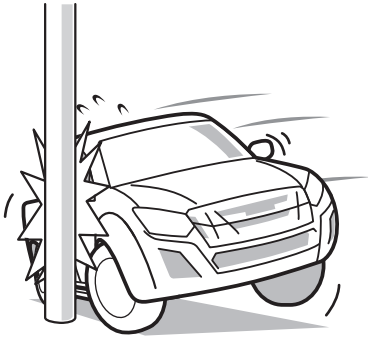

When the vehicle is hit at the engine compartment or cargo bed from the side

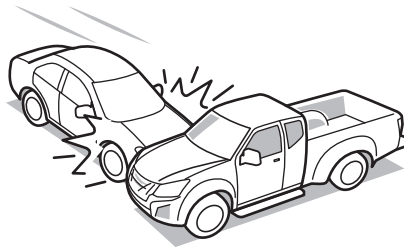

When the vehicle is hit to the side from a frontal angle



When the vehicle has a frontal angle collision

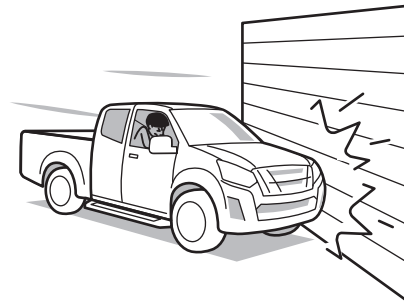



When are the Front Seat Belt with Pretensioner and Front SRS Airbag System Activated Other than in a Collision?

- When the vehicle falls into a pothole or groove in the road
- When the vehicle strongly collides against an obstacle such as a protruding object on the road
- When the vehicle collides against a curb at high speed
- When the vehicle becomes airborne and hits the ground, receiving a strong impact on the bottom of the vehicle

WARNING

- Immediately after the front airbag is inflated, the metal portion that inflates the airbag gets hot. Do not touch it. Doing so may cause a serious injury such as a burn.

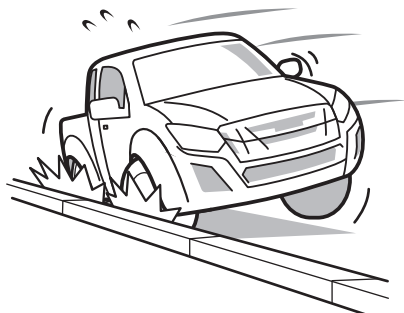

When are the Front Seat Belt with Pretensioner, Side SRS Airbag and Curtain SRS Airbag System Activated Other than in a Collision?

- When the vehicle skids and collides against a curb

WARNING

- Immediately after the side airbag and curtain airbag are inflated, the metal portion that inflates the airbag gets hot. Do not touch it. Doing so may cause a serious injury such as a burn.

When are the Front Seat Belt with Pretensioner and Front SRS Airbag System not Activated?

In the following cases, the front seat belt with pretensioner and front SRS airbag system are not activated even if they are working properly.

When the vehicle is hit from the rear

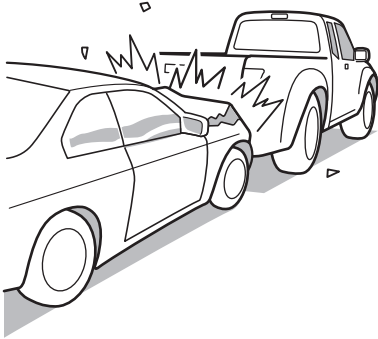

When the vehicle is hit from the side

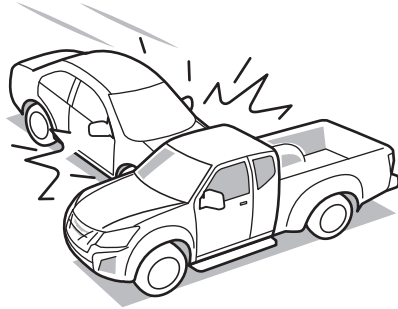

When the vehicle rolls onto its side or upside down

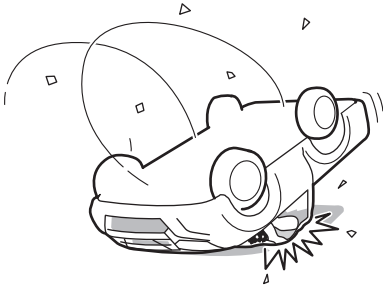

When are the Front Seat Belt with Pretensioner, Side SRS Airbag and Curtain SRS Airbag System not Activated?

In the following cases, the front seat belt with pretensioner, side SRS airbag and curtain SRS airbag system are not activated even if they are working properly.

When the vehicle collides head-on against a parked/stopped vehicle or a moving vehicle with an impact of a certain level or higher



When the vehicle is hit from the rear



When the vehicle rolls onto its side or upside down

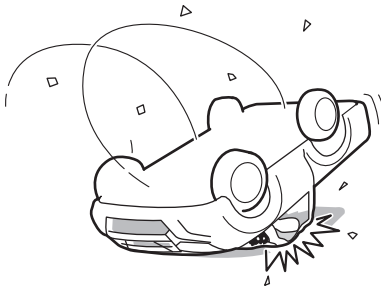

 **WARNING**

- Repainting of the cab panels, repair around the side panel, steering wheel, instrument panel, center console, roof side (in models with side airbag and curtain airbag) and the front seat (in models with side airbag and curtain airbag), installation of accessories such as audio equipment and repair around the dashboard may adversely affect the SRS airbag system or cause a fatal or serious injury due to the impact of the airbag when it unexpectedly inflates. Never make these repairs by yourself, but be sure to consult your Isuzu Dealer.
- If you make modifications to the front of the vehicle (bumper, frame, etc.), install equipment (snow plow, for example), make modifications to the frame, or make a change to the vehicle's height using unauthorized methods and/or materials, the SRS airbag system may fail to operate normally. Be sure to consult your Isuzu Dealer.
- Special treatment is required when an airbag is disposed of. When discarding a vehicle equipped with an SRS airbag system, consult your Isuzu Dealer.

 **CAUTION**

Have your vehicle inspected at the nearest Isuzu Dealer at once in the following cases.

- When the SRS airbag warning light does not go out or comes on during driving.
- When the airbag is inflated.
- When the front airbag was not inflated although the vehicle received a certain level of impact at the front.
- In models with side airbag and curtain airbag, when the side airbag and curtain airbag were not inflated although the vehicle received a certain level of impact at the side.
- When the steering pad surface or instrument panel surface is cracked or otherwise damaged or it receives an impact.
- In models with side airbag and curtain airbag, when the surface of the airbag storage of the front seat or surface of the airbag storage of the roof side is cracked or otherwise damaged, or it receives an impact.

**NOTE**

- When the airbag is inflated, gases like white smoke are produced but this is not a fire. This white smoke is not detrimental to your health. However, if residue (gas and so on) adheres to your eyes and skin, rinse them with water as soon as possible. Although it is rare, a person with delicate skin may suffer from irritation.
- The airbag cannot be reused once it is inflated. Replace it at your Isuzu Dealer.

Deployment of SRS Airbag System

When the vehicle receives an impact exceeding a certain level during a frontal collision, or lateral collision (in models with side airbag and curtain airbag), the SRS airbag system is activated and airbag instantly inflates.

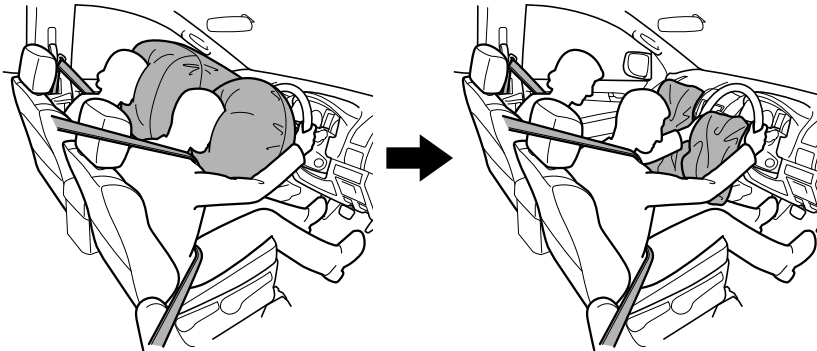
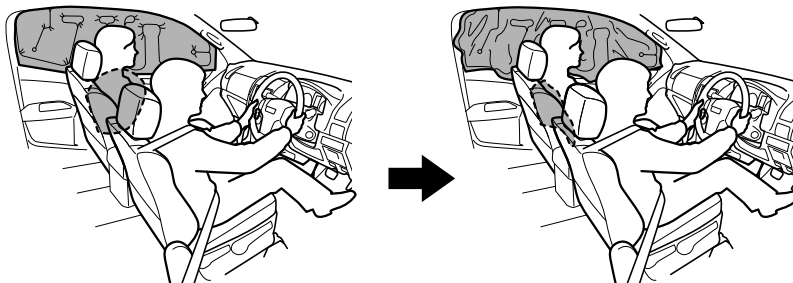
Deployment of front airbag**Deployment of side airbag and curtain airbag**

When Does An SRS Airbag System Develop Its Full Effect?

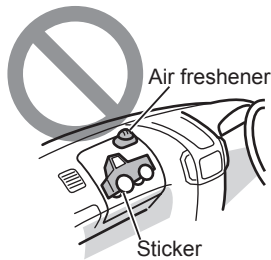
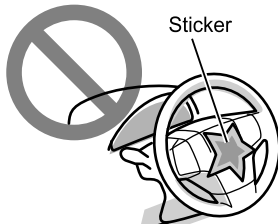
 **WARNING**

- Before driving the vehicle, properly adjust your seat for proper driving position and wear the seat belt correctly. Do not sit closer than necessary to the steering wheel and do not lean over it. (Leave a space of 25 cm (10 in) or more between your chest and the center of the steering wheel.) Do not allow the passenger to put his/her hands or feet on the instrument panel and to sit with his/her face or chest close to it. When the airbags are activated, you or the passenger may suffer a burn on or serious injury to the arm or face.
- In models with side airbag and curtain airbag, do not lean against the door and roof side. When the airbags are activated, you may suffer a burn on or serious injury to the arm or face.
- If the steering wheel is changed to a non-standard one or a sticker is attached to the steering wheel pad, there could be a danger of system malfunction or the sticker flying off in the event of system activation. Attaching stickers or placing such things as accessories or air fresheners on the top surface of the instrument panel is also dangerous. They may prevent normal operation of the airbag or could fly off in the event of system activation.

WARNING (Continued)

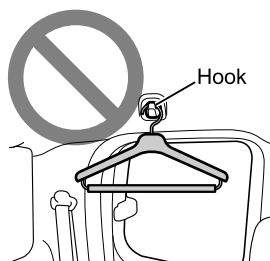
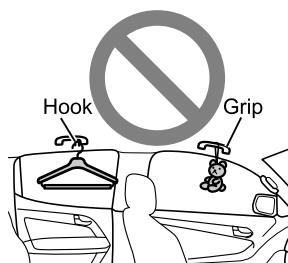
**WARNING (Continued)**

- In models with side airbag and curtain airbag, do not attach seat covers under any circumstances. If a seat cover is attached or objects are placed in the area in which the side airbag inflates, the side airbag will not function correctly. Also, there could be a danger of objects flying off in the event of the system activation. In addition, if hard objects such as hangers or accessories are attached to the grip or coat hook, they may prevent normal operation of the curtain airbag and could fly off in the event of system activation.

When Carrying a Child in the Vehicle



WARNING

- Be sure to observe the following precautions when carrying a child in the vehicle. Otherwise the child may be fatally injured by the impact from an inflating airbag.
 - Do not drive with a child standing in front of any of the airbags, or sitting on your lap. Doing so is dangerous because the child would receive a very strong impact by an inflating airbag.
 - Never use a rearward-facing CRS on a seat protected by an active airbag in front of it, death or serious injury to the child can occur.
- For safety, place children in the back seat.

Handling of SRS Airbag System

⚠ WARNING

- Do not remove or disassemble the airbag. Doing so may cause a malfunction or inadvertent activation.
- Do not place anything near the airbag. You may suffer an injury when an object is thrown by the inflation force of the airbag.
- Do not take a rest using the steering wheel as a pillow or with your arms or legs resting on it. If the vehicle is stopped with the power mode in "ON" (models with passive entry and start system) or the starter switch in the "ON" position (models without passive entry and start system) and an impact exceeding a certain level occurs to the front of the vehicle, the airbag will inflate and may injure you due to the strong impact.
- Do not drive the vehicle with something placed between you and airbag or held on your lap. If the airbag inflates, the objects may be thrown and hit your face. Doing so also hinders normal activation of the airbag, which is dangerous.
- Do not wet the airbag sensor with water or subject it to an impact. The system may malfunction; this is very dangerous.



CONTROLS AND INSTRUMENTS

4

STARTING AND STOPPING THE ENGINE

4-3

**INSTRUMENTS, WARNING LIGHTS AND
INDICATOR LIGHTS**

4-15

SWITCHES

4-115

DRIVING CONTROLS

4-135

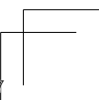
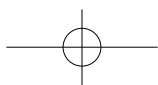
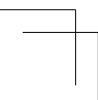
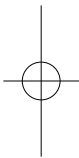
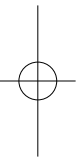
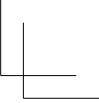
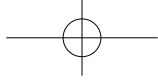

STARTING AND STOPPING THE ENGINE

• Starting the Engine	4-4
• Warm-up System	4-11
• Stopping the Engine	4-12

Starting the Engine

Make sure that the switches, including those for the windshield wiper, light control and air conditioner, are in the off position.

Switch the power mode to "ON" (models with passive entry and start system) or turn the starter switch to the "ON" position (models without passive entry and start system) to check that the warning and indicator lights turn on normally and the fuel level is proper.



ADVICE

- Using a dirty or dusty key may possibly damage the starter switch. Make sure to wipe off any dirt or dust, etc., before inserting the key (models without passive entry and start system).
- Do not use starting aids such as ether in the air intake system. Such aids can cause immediate engine damage.
- When the engine does not start, wait for 1 minute or more before pushing the engine start/stop button (models with passive entry and start system) or turning the starter switch (models without passive entry and start system) again.
- Do not rev the engine when it is still cold immediately after having been started.

Engine Start/Stop Button (Models with Passive Entry and Start System)

→ Refer to page 4-116

Starter Switch (Models without Passive Entry and Start System)

→ Refer to page 4-119

Starting the Engine



WARNING

- Do not keep the starter switch in the "START" position for more than approximately 10 seconds (models without passive entry and start system). Operating the starter for too long might cause battery failure or might result in overheating and even a fire.

**CAUTION**

- In manual transmission models, firmly engage the parking brake when you sit in the driver's seat before starting the engine. Also, be sure to start the engine while pressing the clutch pedal and after making sure that the gearshift lever is in the "N" position.
- In automatic transmission models, firmly engage the parking brake when you sit in the driver's seat, check that the selector lever is in the "P" position, and firmly press the brake pedal before starting the engine.
- In manual transmission models, if you start the engine from outside the vehicle when the gearshift lever is in a position other than "N", the vehicle may start moving. This is very dangerous. Never start the engine from outside the vehicle.

**ADVICE**

- Do not depress the accelerator pedal before starting. When the accelerator pedal is depressed before the power mode is switched to "ON" (models with passive entry and start system) or the starter switch is turned to "ON" (models without passive entry and start system), the start fuel enrich system may not function correctly. Accordingly, starting becomes substantially more difficult.
- At low ambient temperatures, a cold engine may emit more smoke (white smoke) than usual.

**NOTE**

[Preheating]

- Diesel engines are compression ignited, which makes them difficult to start when they are cold because the compression alone cannot create a temperature high enough for fuel to ignite. "Preheating" means warming the compressed air inside the combustion chambers to facilitate engine starting. Be sure to start the engine after the glow plug indicator light has gone out.

Engine Start/Stop Button (Models with Passive Entry and Start System)

→ Refer to page 4-116

Starter Switch (Models without Passive Entry and Start System)

→ Refer to page 4-119

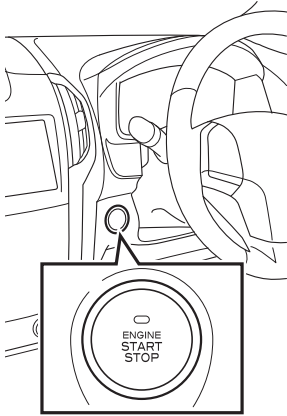
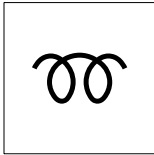
**Glow plug indicator light****Models with Passive Entry and Start System**

1. Make sure that the parking brake lever is fully pulled.
If your vehicle is a manual transmission model, make sure that the gearshift lever is in the "N" position and then depress the clutch pedal and brake pedal fully.
In an automatic transmission model, make sure that the selector lever is in the "P" position and then depress the brake pedal fully.
2. With the pedal(s) depressed, push the engine start/stop button. When the engine start/stop button is pushed, the glow plug indicator light comes on and will then go out in approximately 0.5 seconds if the engine is warm.
If the engine is cold, it will go out after remaining on for a maximum of approximately 7 seconds.
3. The starter will then automatically start the engine.

Operating range for starting the engine

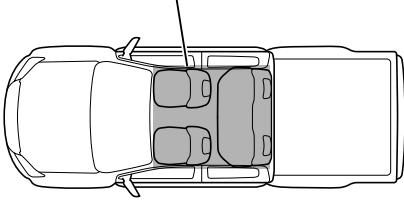

NOTE

- By using the passive entry and start system to verify the electronic key, the engine can be started and the power mode can be switched.
- The engine can be started in power modes "OFF", "ACC", and "ON".
- When the engine is cold and glow plug warming is necessary, the accessory power will turn off and the audio system will remain off while the engine is waiting to be started.
- To stop the engine from starting during operation, push the engine start/stop button and switch the power mode "ACC" or "OFF".
- When attempting to start the engine, the starter will crank for a maximum of 20 seconds.
- The power mode will switch to "ON" when the engine starts.
- The operating range for starting the engine is within the vehicle, excluding above the instrument panel, in storage areas such as the glove box or door pocket, as well as under the seat or on the floor in front of the driver and passenger seats.
- It may still be possible to start the engine when the electronic key is outside the vehicle and near to the doors or windows.

NOTE (Continued)

NOTE (Continued)

[Engine starting is delayed]

- When attempting to start the engine, the glow plug indicator light will come on if the engine is cold. In such cases, engine starting will be delayed until the glow plugs have sufficiently warmed. Continue depressing the clutch pedal (manual transmission models) or the brake pedal (automatic transmission models) until the engine starts.

[The engine will not start]

- If your vehicle is a manual transmission model, the engine cannot be started unless the gearshift lever is in the "N" position and the clutch pedal is depressed. If your vehicle is an automatic transmission model, the engine cannot be started unless the selector lever is in the "P" or "N" position and the brake pedal is depressed.
- When the engine does not start, check that the gearshift lever is in the "N" position (manual transmission models) or that the selector lever is in the "P" position (automatic transmission models), then switch the power mode to "OFF". Then attempt to start the engine using the correct procedure.
- The engine may not start or stop if the engine start/stop button is only pushed for a brief moment.

NOTE (Continued)

NOTE (Continued)

- The engine may not be able to be started immediately after it has been repeatedly started and stopped within a short period of time. In such a case, wait approximately 10 seconds or more before attempting to start the engine again.
- When the engine start/stop button indicator light flashes in green after an attempt to start the engine has been made, the engine will not be able to be started due to the steering wheel lock not being unlocked. Try starting the engine again while turning the steering wheel to the right and left. The steering wheel lock will not unlock if the vehicle battery has gone flat.
- In order to prevent the battery from becoming discharged, starting operations may be terminated during operation.
- If the engine cannot be started, please refer to "Emergency Engine Starting (Models with Passive Entry and Start System)". It may be possible to start the engine using the procedure shown on that page.

Engine Start/Stop Button (Models with Passive Entry and Start System)

→ Refer to page 4-116

Emergency Engine Starting (Models with Passive Entry and Start System)

→ Refer to page 7-11

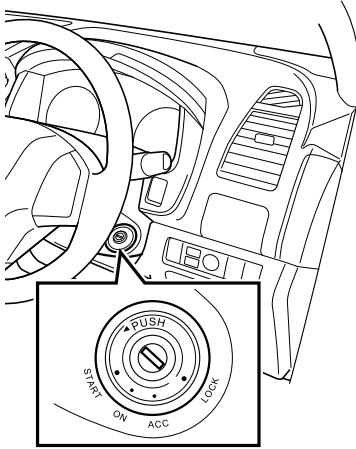

Glow plug indicator light

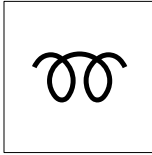

Models without Passive Entry and Start System

1. Make sure that the parking brake lever is fully pulled.
If your vehicle is a manual transmission model, depress the clutch pedal and brake pedal fully. In an automatic transmission model, make sure that the selector lever is in the "P" position and then depress the brake pedal fully.
2. When the starter switch is turned to the "ON" position, the glow plug indicator light comes on and will then go out in approximately 0.5 seconds if the engine is warm. If the engine is cold, it will go out after remaining on for a maximum of approximately 7 seconds.
3. After confirming that the glow plug indicator light has gone out, turn the starter switch to the "START" position to start the engine.

Warm-up System

This vehicle is equipped with a warm-up system. The warm-up system is a system that automatically increases the idling speed to warm the engine and improve heater operation when the engine is started in cold weather (outside temperature of approximately 5°C (41°F) or below). When the warm-up system is operated, the engine idle speed will increase to approximately 1,400 r/min. This does not indicate a failure. The warm-up system will automatically turn off when the outside air temperature increases (to approximately 10°C (50°F)) or when the engine is warmed. Also, the warm-up system will stop if any of the following occur during its operation.

- The brake pedal is depressed
- The clutch pedal is depressed (manual transmission models)
- The gearshift lever is placed in any position other than "N" (manual transmission models)
- The selector lever is placed in any position other than "P" or "N" (automatic transmission models)



NOTE

- The engine idling speed is slowly decreased when the warm-up system is stopped by the operation of the brake pedal or clutch pedal.
- The engine idling speed is immediately decreased when the warm-up system is stopped by the operation of the gearshift lever or selector lever.

Stopping the Engine

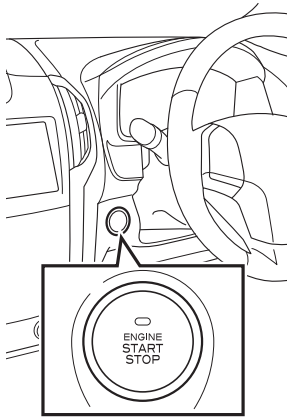

Models with Passive Entry and Start System

1. Bring the vehicle to a complete stop and firmly apply the parking brake. In manual transmission models, place the shift lever in the "N" position. In automatic transmission models, place the selector lever in the "P" position.
2. Push the engine start/stop button once and the engine will stop.



WARNING

- In the case of an emergency, the engine can be stopped while the vehicle is in motion by performing the following:
 - Continue pushing the engine start/stop button for 3 seconds or more.
 - Push the engine start/stop button 3 times or more within 2 seconds.
- For details on stopping the engine in the case of an emergency, please refer to "Emergency Engine Stopping (Models with Passive Entry and Start System)".



ADVICE

- The power mode will switch to "OFF" when the engine stops. In automatic transmission models, the power mode will switch to "ACC" when the selector lever is placed in any position other than "P". To prevent the battery from going flat, switch the power mode to "OFF" after stopping the engine.

Engine Start/Stop Button (Models with Passive Entry and Start System)

→ Refer to page 4-116

Emergency Engine Stopping (Models with Passive Entry and Start System)

→ Refer to page 7-10

Models without Passive Entry and Start System

Firmly apply the parking brake.

With the accelerator pedal released, turn the starter switch to the "ACC" or "LOCK" position.

**ADVICE**

- To prevent the battery from going flat, turn the starter switch to the "ACC" or "LOCK" position after stopping the engine. If you leave the vehicle for an extended period of time, place the starter switch in the "LOCK" position.



INSTRUMENTS, WARNING LIGHTS AND INDICATOR LIGHTS

• How to Read the Instruments (Instruments Layout)	4-16
• Speedometer	4-18
• Odometer and Trip Meter	4-18
• Tachometer	4-21
• Engine Coolant Temperature Gauge	4-22
• Fuel Gauge	4-23
• Calendar Display	4-25
• Clock Display	4-25
• Warning and Indicator Lights Layout	4-26
• Illumination of Center Display	4-28
• Multi-Information Display (MID)	4-30
• Liquid Crystal Display (LCD)	4-62
• Warning and Indicator Lights	4-70
• Warning Buzzer	4-111

How to Read the Instruments (Instruments Layout)

Models with MID

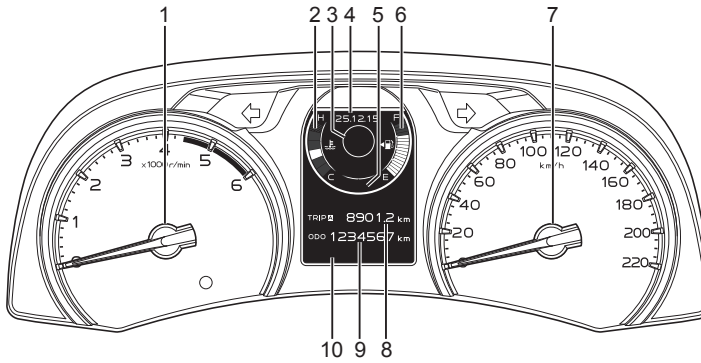

Models with LCD

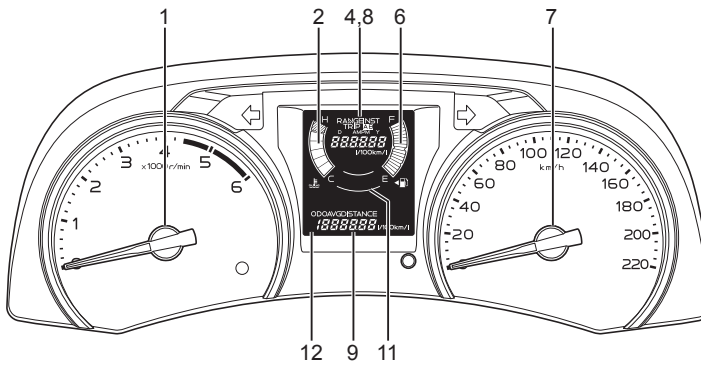

No.	Name	Reference page	No.	Name	Reference page
1	Tachometer	4-21	6	Fuel gauge	4-23
2	Engine coolant temperature gauge	4-22	7	Speedometer	4-18
3	Outside temperature display (manual transmission model)	4-61	8	Trip meter	4-19
	Shift indicator (automatic transmission model)	4-142	9	Odometer	4-18
4	Calendar/clock	4-25	10	Multi-information display (MID)	4-30
5	Gear shift indicator (GSI) (manual transmission model)	4-139	11	Gear shift indicator (GSI) (manual transmission model)	4-139
	Outside temperature display (automatic transmission model)	4-61		Shift indicator (automatic transmission model)	4-142
			12	Liquid crystal display (LCD)	4-62

Speedometer

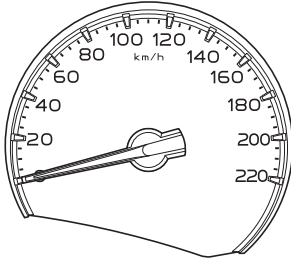

The speedometer indicates the vehicle speed in km/h or MPH.

Odometer and Trip Meter

Odometer

The total distance traveled by your vehicle is indicated in km if the speedometer is graduated in kilometer units. The total distance traveled by your vehicle is indicated in miles if the speedometer is graduated in both mile and kilometer units. The unit on the display cannot be switched.

TRIP Δ 890.2 km
ODO 1234567 km

ODO
1234567 km

Models with MID

If you select the odometer display when the power mode is "ON" (models with passive entry and start system) or when the starter switch is in the "ON" position (models without passive entry and start system), the odometer ("ODO") will be displayed on the MID.

Multi-Information Display (MID)

→ Refer to page 4-30

MID Main Routine → Refer to page 4-37

Models with LCD

If you select the odometer display when the starter switch is in the "ON" position, the odometer ("ODO") will be displayed on the LCD.

Liquid Crystal Display (LCD)

→ Refer to page 4-62

LCD Main Routine → Refer to page 4-63

Trip Meter

Use the trip meter to learn the distance between the specific points or the distance traveled during a specific period of time. In the case of a speedometer graduated in kilometers, the value to the right of the decimal point indicates 100-m units, whereas in the case of a speedometer graduated in both miles and kilometers, this value indicates 0.1-mile units.

- : MID mode R switch - press once
- ▶ : MID mode L switch - press once

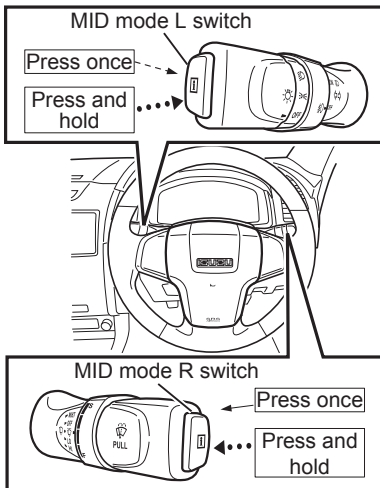
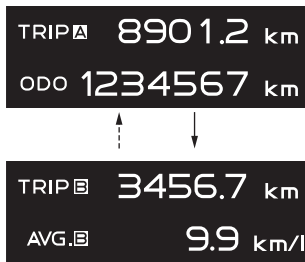

Models with MID

If you select the trip meter display when the power mode is "ON" (models with passive entry and start system) or when the starter switch is in the "ON" position (models without passive entry and start system), this will be displayed on the MID. In addition, two separate distances can be associated with trip meter A ("TRIP A") and trip meter B ("TRIP B"). Switch the trip meter by pressing the MID mode R switch or MID mode L switch. When resetting, display the trip meter and press and hold the MID mode R switch or MID mode L switch.



NOTE

- Trip meter B ("TRIP B") and the trip meter B section average fuel economy ("AVG. B") are interrelated. The trip meter B section average fuel economy ("AVG. B") is reset when trip meter B ("TRIP B") is reset.

Multi-Information Display (MID)

→ Refer to page 4-30

MID Main Routine → Refer to page 4-37

Trip Meter B Section Average Fuel Economy → Refer to page 4-39

→ : Trip knob - press once

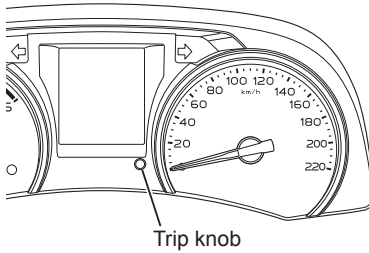
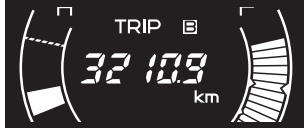
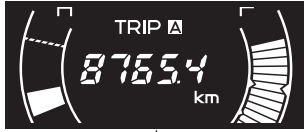

Models with LCD

If you select the trip meter display when the starter switch is in the "ON" position, this will be displayed on the LCD. In addition, two separate distances can be associated with trip meter A ("TRIP A") and trip meter B ("TRIP B"). Switch the trip meter by pressing the trip knob. When resetting, display the trip meter and press and hold the trip knob.

Liquid Crystal Display (LCD)

→ Refer to page 4-62

LCD Main Routine → Refer to page 4-63

Tachometer

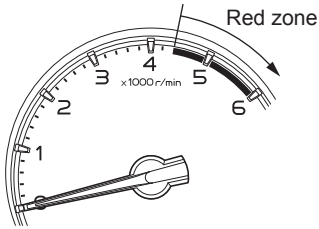

The tachometer indicates the engine speed in revolutions per minute (r/min). (Graduation "1" on the scale indicates 1,000 r/min.) The red zone indicates a range of dangerous engine speeds beyond permissible levels.

Do not drive your vehicle with the pointer of the tachometer in the red zone.

The graduation and the red zone of tachometer are various depending on the models fitted.



ADVICE

- Exercise extreme caution when shifting down on a steep downslope. The engine speed may easily exceed the critical speed, which can seriously damage the engine.

Appropriate Gearshifts

→ Refer to page 2-28

Gearshift Lever → Refer to page 4-138

Engine Coolant Temperature Gauge

Models with MID

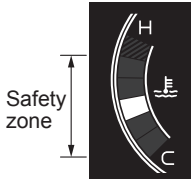

Models with LCD

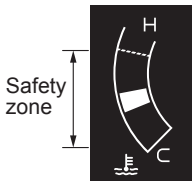

Engine overheat warning light (models with MID)



Engine overheat warning light (models with LCD)

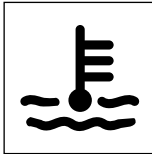

With the power mode in "ON" (models with passive entry and start system) or the starter switch in the "ON" position (models without passive entry and start system), this gauge indicates the temperature of the engine coolant. "C" means cold while "H" means hot. If the engine overheats, the engine coolant temperature gauge will indicate "H" zone and flash, the engine overheat warning light will come on, and the engine overheat warning buzzer will sound. During operation, the gauge should normally indicate within the safety zone.



ADVICE

- If the gauge goes up above the upper limit of the safety zone and enters the "H" zone while you are driving, the engine is likely to overheat. Immediately pull safely off the road out of the way of any traffic and take necessary actions to deal with engine overheating.
- If the gauge is near the "H" zone but is still in the safety zone, this is not a malfunction. However, check the coolant level in the reserve tank. Add coolant as required.
- The engine can seize up if it is stopped immediately after driving. Take appropriate actions for engine overheating.

Warning Buzzer → Refer to page 4-111

Engine Coolant → Refer to page 6-40

When the Engine Overheats

→ Refer to page 7-32

Fuel Gauge

Models with MID



Models with LCD



With the power mode in "ON" (models with passive entry and start system) or the starter switch in the "ON" position (models without passive entry and start system), this gauge indicates the quantity of fuel remaining in the fuel tank. "F" means the tank is full while "E" means the tank is almost empty.



NOTE

- When the remaining fuel level has become low, the gauge will reach the bottom level and will flash.
- After filling up the fuel tank, it takes a while for the gauge to stabilize after the power mode is switched to "ON" (models with passive entry and start system) or the starter switch is turned to the "ON" position (models without passive entry and start system).
- If the fuel tank is filled with the engine off, but the power mode in "ON" (models with passive entry and start system) or the starter switch in the "ON" position (models without passive entry and start system), the fuel gauge takes a while to show the correct reading. In such a case, switch the power mode to "OFF" or "ACC" and then to "ON" (models with passive entry and start system), or turn the starter switch to the "LOCK" or "ACC" positions and then to "ON" again (models without passive entry and start system).

Low fuel warning light**Warning message (models with MID)**

In models with an MID, when the vehicle is running out of fuel, the low fuel warning light comes on after the warning message is displayed on the MID for approximately 3 seconds and then goes out.

In models with an LCD, when the vehicle is running out of fuel, the low fuel warning light comes on.

**ADVICE**

- If your vehicle has run out of fuel, air bleeding procedure must be performed.

Low Fuel Warning Light

→ Refer to page 4-89

When the Fuel Runs Out

→ Refer to page 7-28

Calendar Display

Models with MID

In vehicles with a factory-equipped audio system, the calendar can be displayed on the MID. It is also possible to change the display so the calendar does not show. Under "CALENDAR" in the "SELECT MODE", the calendar display on/off and date can be set.

Select Mode → Refer to page 4-45

Models with LCD

In vehicles with a factory-equipped audio system, the calendar can be displayed on the LCD. The trip knob can be used to set the date.

Liquid Crystal Display (LCD)

→ Refer to page 4-62

Clock Display

Models with MID

In vehicles without a factory-equipped audio system, the clock can be displayed on the MID. It is also possible to change the display so the clock does not show. Under "CLOCK" in the "SELECT MODE", the clock display on/off and time can be set.

Select Mode → Refer to page 4-45

Models with LCD

In vehicles without a factory-equipped audio system, the clock can be displayed on the LCD. The trip knob can be used to set the time setting.

Liquid Crystal Display (LCD)

→ Refer to page 4-62

Warning and Indicator Lights Layout

Models with MID

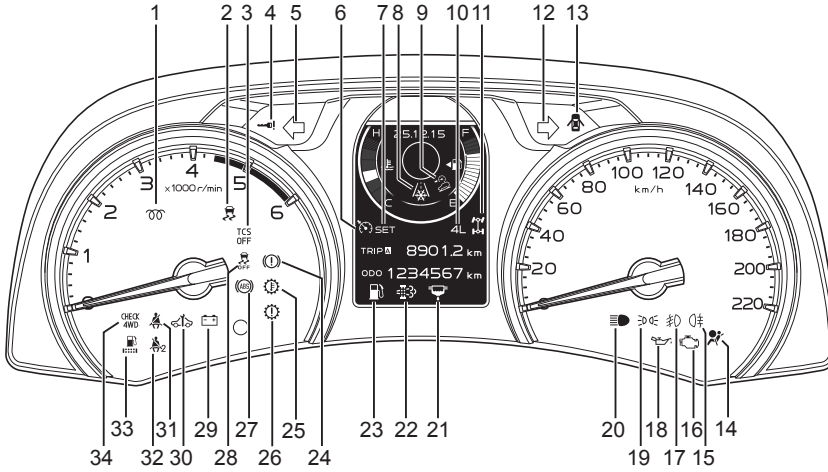

Models with LCD

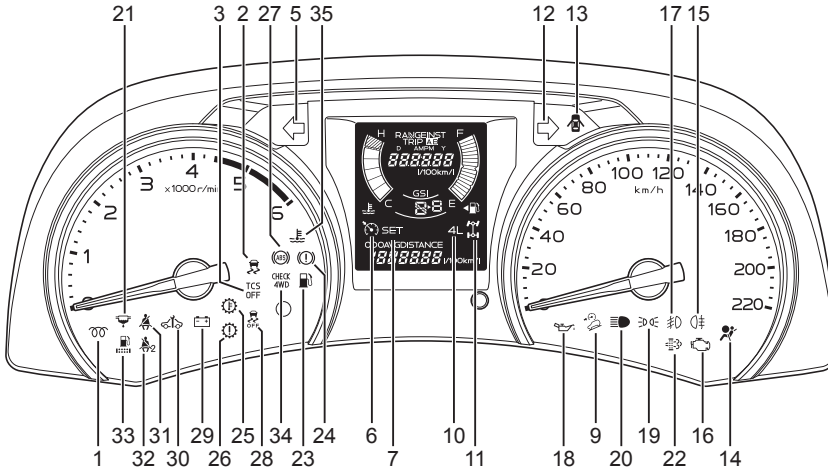

No.	Name	Reference page
1	Glow plug indicator light	4-103
2	ESC warning light	4-76
3	TCS OFF indicator light	4-104
4	Passive entry and start system warning light	4-91
5	Turn signal indicator light – left	4-102
6	Cruise control main indicator light	4-106
7	Cruise control set indicator light	4-106
8	Icy road warning light	4-88
9	Hill descent control indicator light	4-109
10	4WD low indicator light	4-108
11	4WD indicator light	4-107
12	Turn signal indicator light – right	4-102
13	Door open warning light	4-90
14	SRS airbag warning light	4-72
15	Rear fog light indicator light	4-103
16	Malfunction indicator light (MIL)	4-83
17	Front fog light indicator light	4-103
18	Engine oil pressure warning light	4-77

No.	Name	Reference page
19	Light position indicator light	4-102
20	High beam indicator light	4-102
21	Water separator warning light	4-85
22	DPD operator regeneration indicator light	4-110
23	Low fuel warning light	4-89
24	Brake system/parking brake warning light	4-73
25	Automatic transmission fluid temperature warning light	4-87
26	Check trans warning light	4-86
27	ABS warning light	4-75
28	ESC OFF indicator light	4-105
29	Generator warning light	4-82
30	SVS indicator light	4-84
31	Seat belt warning light (driver seat)	4-70
32	Seat belt warning light (front passenger seat)	4-71
33	Fuel filter warning light	4-86
34	CHECK 4WD warning light	4-87
35	Engine overheat warning light	4-78

Illumination of Center Display

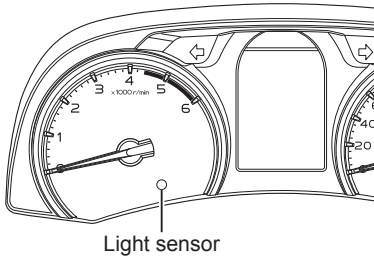

Models with MID

When the power mode is "ON" (models with passive entry and start system) or the starter switch is in the "ON" position (models without passive entry and start system), the illumination brightness is automatically adjusted according to the brightness inside the vehicle. The initial setting is "AUTO".

By changing to "MANUAL", the illumination brightness of both the meter and MID can be individually set.

Perform "MANUAL" setting at "ILLUMI LEVEL" displayed in the MID main routine, after changing from "AUTO" to "MANUAL" in "ILLUMI MODE" of "SELECT MODE".

MID Main Routine → Refer to page 4-37

Illumi Level → Refer to page 4-44

Select Mode → Refer to page 4-45



CAUTION

- Do not place any objects in front of the sensor. Doing so will reduce the sensitivity of the sensor, and will not operate properly.

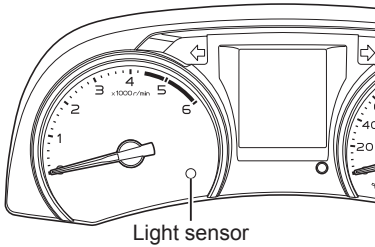

Light sensor

Models with LCD

When the starter switch is in the "ON" position, the illumination brightness is automatically adjusted in two levels (daytime and nighttime) according to the brightness inside the vehicle. Perform the following operation to turn off the automatic brightness adjustment.

**CAUTION**

- Do not place any objects in front of the sensor. Doing so will reduce the sensitivity of the sensor, and will not operate properly.
- When the headlights are turned on during daytime driving with automatic brightness adjustment turned off, the fuel gauge and engine coolant temperature gauge may be difficult to see.

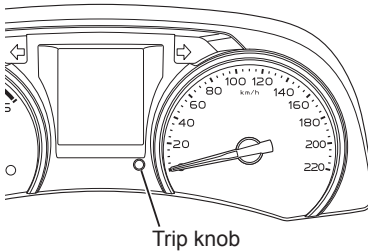

Trip knob

1. Hold in the trip knob and turn the starter switch to the "ON" position.
2. Turn the headlights on and off three times within 10 seconds. When the setting is turned off, a beep will sound two times.

To turn on the automatic brightness adjustment, perform steps 1-2 again.

**NOTE**

- The center display automatic brightness adjustment will not be turned off unless the headlights are turned on and off three times.

Multi-Information Display (MID)

Multi-information display (MID)

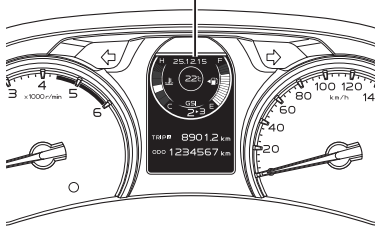

Manual transmission model

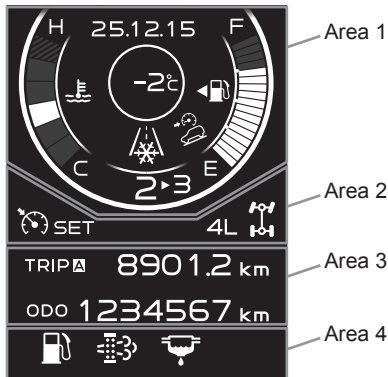

Automatic transmission model

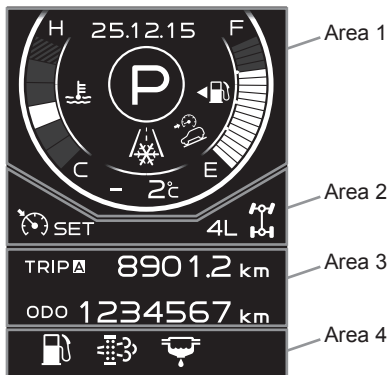

The MID in the instrument panel can display the following information.

Display area 1:

- Engine coolant temperature gauge
- Fuel gauge
- Calendar/clock
- Outside temperature display
- Warning light
- Indicator light
- Gear shift indicator (GSI) (manual transmission model)
- Shift indicator (automatic transmission model)

Display area 2:

- Indicator light

Display area 3:

- Warning-related information
- Operation-related information
- Odometer
- Trip meter
- Fuel economy
- Average vehicle speed
- Driving distance
- Elapsed time
- Range (possible driving range)
- Diesel particulate defuser (DPD) state
- Outside temperature
- Maintenance distance

Display area 4:

- Warning light
- Indicator light













Full screen display:



- Warning-related information
- Operation-related information
- Setting screen



Use the MID mode R switch and MID mode L switch to select the desired screen or function.



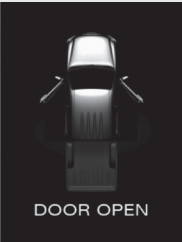

MID Main Routine → Refer to page 4-37



Warning and Indicator Lights Display

Display indication	Description	Reference page
 OVER HEAT	When the engine overheats.	4-78
 RELEASE PARK BRAKE	When the vehicle is driven while the parking brake has not been released.	4-74
 LOW FUEL	Fuel level is too low.	4-89
 WATER SEPARATOR	When water in the water separator needs draining.	4-85
 CHECKING PM LEVEL	When operator regeneration of DPD is required.	4-110
 2H	When the 4WD switch is used to select 2WD.	4-108
 4H	When the 4WD switch is used to select "4H (4WD high)".	4-107
 4L	When the 4WD switch is used to select "4L (4WD low)".	4-108
 CRUISE MAIN POWER	When the cruise control main switch is pressed and the function is activated.	4-106
 CRUISE SET	When the cruise control set switch is pressed and the vehicle enters the cruise control mode.	4-106
 HILL DESCENT CONTROL	When the hill descent control switch is pressed and the function is activated.	4-109
 LIGHT OFF	When the light control switch is set to "OFF" or "LOCK", the power mode is switched to "OFF" (models with passive entry and start system) or the starter switch is turned to the "LOCK" position (models without passive entry and start system) and the driver's door is opened.	4-90
 KEY REMAIN	When the starter switch is in the "ACC" or "LOCK" position, the driver's door is opened and the key has not been removed. (models without passive entry and start system)	4-90

Display indication	Description	Reference page
 <p>NO ELECTRONIC KEY</p>	<p>If locking of an unlocked door is attempted with the electronic key not within operating range for locking and unlocking the doors.</p> <p>If the electronic key is carried outside the vehicle and then the doors are closed with the power mode in "ACC" or "ON".</p> <p>If the power mode is "OFF" and the engine start/stop button is pushed with the electronic key not within operating range for starting the engine. (models with passive entry and start system)</p>	<p>4-91</p>
 <p>PUSH START BUTTON WHILE TURNING STEERING WHEEL</p>	<p>If the steering wheel lock is not released even though the engine start/stop button is pushed. (models with passive entry and start system)</p>	<p>4-93</p>
 <p>DOOR OPEN</p>	<p>If door locking is attempted by pressing the lock button on the driver side door handle or the electronic key when the doors are open. (models with passive entry and start system)</p>	<p>4-93</p>

Display indication	Description	Reference page
 <p>SHIFT TO N</p>	<p>If the electronic key is carried outside the vehicle and then the doors are closed with the power mode in "OFF" and the selector lever in a position other than "P" (automatic transmission model).</p>	
 <p>SHIFT TO P</p>	<p>If the selector lever is moved to a position other than "P" with the driver side door open (automatic transmission model). If starting of the engine is attempted by pushing the engine start/stop button with the selector lever in a position other than "P" or "N" (automatic transmission model). If starting of the engine is attempted by pushing the engine start/stop button with the gearshift lever in a position other than "N" (manual transmission model).</p>	4-94
<p>TO POWER OFF SHIFT TO P THEN PUSH START BUTTON</p>	<p>If an attempt to switch the power mode from "ON" to "OFF" is made with the selector lever in a position other than "P" (automatic transmission model). (models with passive entry and start system)</p>	
 <p>TURN OFF THE POWER</p>	<p>If door locking is attempted by pressing the lock button on the driver side door handle or electronic key with the power mode in "ON" or "ACC". (models with passive entry and start system)</p>	4-95

Display indication	Description	Reference page
 <p data-bbox="238 473 419 512">LOW BATTERY ELECTRONIC KEY</p>	<p data-bbox="465 372 958 480">If the battery voltage of the electronic key is low when the power mode is switched from "ON" to "OFF" (or "ACC"). (models with passive entry and start system)</p>	<p data-bbox="1018 413 1063 435">4-96</p>
 <p data-bbox="238 754 419 775">CHECK SYSTEM</p>	<p data-bbox="465 620 944 775">If an error occurs to the passive entry and start system when door locking is attempted by pressing the lock button on the driver side door handle or by pushing the engine start/stop button. (models with passive entry and start system)</p>	<p data-bbox="1018 686 1063 707">4-97</p>
 <p data-bbox="238 1010 419 1068">POWER MANAGEMENT SYSTEM ERROR</p>	<p data-bbox="465 921 918 1023">If an error occurs to the power management system when the engine start/stop button is pushed. (models with passive entry and start system)</p>	<p data-bbox="1018 960 1063 982">4-98</p>
 <p data-bbox="238 1292 419 1331">STEERING LOCK SYSTEM ERROR</p>	<p data-bbox="465 1195 918 1297">If an error occurs to the steering wheel lock system when the engine start/stop button is pushed. (models with passive entry and start system)</p>	<p data-bbox="1018 1234 1063 1256">4-99</p>

Display indication	Description	Reference page
	<p>This message appears on the display when the power mode is in "ACC". (models with passive entry and start system)</p>	<p>4-100</p>
		

Display indication	Description	Reference page
 <p data-bbox="251 449 406 526">PUT ELECTRIC KEY CLOSE TO START BUTTON</p>	<p data-bbox="465 655 942 736">This message appears on the display when the electronic key battery goes flat. (models with passive entry and start system)</p>	<p data-bbox="1010 682 1071 706">4-101</p>
<p data-bbox="257 602 400 620">INFORMATION</p> <p data-bbox="257 643 406 790">TO START STEP TO THE CLUTCH AND SHIFT TO N THEN PUSH START BUTTON</p>		
<p data-bbox="257 876 400 894">INFORMATION</p> <p data-bbox="257 935 406 1046">TO START STEP TO THE BRAKE THEN PUSH START BUTTON</p>		

MID Main Routine

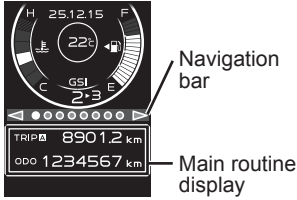

Basic operation and the screens of the MID main routine display are shown.

Use the MID mode R switch and MID mode L switch to select the desired screen or function.



NOTE

- A navigation bar appears whenever the MID mode R switch or MID mode L switch is pressed. The current display is indicated by the illuminated circle on the navigation bar.

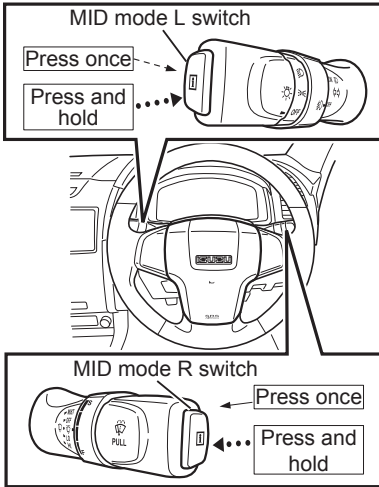

- : MID mode R switch - press once
- : MID mode L switch - press once
- ▶ : MID mode R switch/MID mode L switch - press and hold

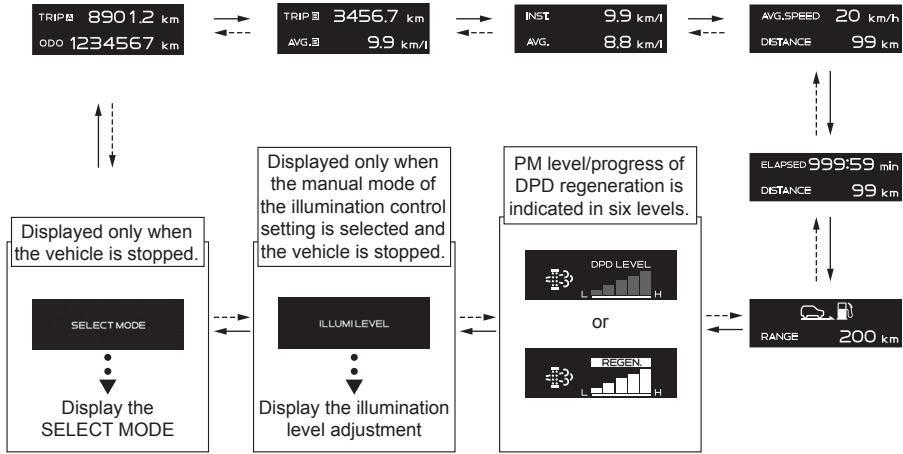

Operation-Related Information Display

The operating conditions and operating control information of fuel economy, average vehicle speed and driving distance, elapsed time and driving distance, and range (possible driving range) are displayed.



NOTE

- The system calculates and stores the distance traveled and fuel consumption while driving to encourage the operator to drive the vehicle economically.
- The operation-related information display may differ from the actual values due to the conditions of roads, wind, cargo weight, number of passengers, the rear body, etc. Use the indications only as guidelines.
- The unit of distance is indicated using "km" and the vehicle speed is indicated using "km/h" if the speedometer is graduated in kilometer units. The unit of distance is indicated using "miles" and the vehicle speed is indicated using "mph" if the speedometer is graduated in both mile and kilometer units.

TRIP	3456.7	km
AVG.	9.9	km/l

Trip Meter B Section Average Fuel Economy

Average fuel economy of the trip meter B section ("AVG. B") is displayed.



NOTE

- Trip meter B ("TRIP B") and the trip meter B section average fuel economy ("AVG. B") are interrelated. The trip meter B section average fuel economy ("AVG. B") is reset when trip meter B ("TRIP B") is reset.
- With "UNITS" in "SELECT MODE", the unit of the fuel economy display can be changed to the desired unit from "km/l", "l/100km" or "mpg".

Trip Meter → Refer to page 4-19
UNITS (Fuel Economy Unit Setting)
 → Refer to page 4-47

Driving Distance Fuel Economy

Fuel consumption of the driving distance ("DISTANCE") section is displayed.

Display types can be changed with "CUSTOMIZE" in "SELECT MODE".

Average Vehicle Speed and Driving Distance → Refer to page 4-41

Elapsed Time and Driving Distance → Refer to page 4-41

CUSTOMIZE (Fuel Economy Display Type Setting) → Refer to page 4-53

Message	Display indication	Description
Fuel economy (numerical display)		Instantaneous fuel economy ("INST.") and average fuel economy ("AVG.") are indicated in figures.
Fuel economy (graphical display)		Instantaneous fuel economy ("INST.") is indicated in the graph and average fuel economy ("AVG.") is indicated in figures.
Fuel economy and driving distance		Average fuel economy ("AVG.") and driving distance ("DISTANCE") are indicated in figures.



NOTE

- With "UNITS" in "SELECT MODE", the unit of the fuel economy display can be changed to the desired unit from "km/l", "l/100km" or "mpg".

UNITS (Fuel Economy Unit Setting)

→ Refer to page 4-47

AVG. SPEED 20 km/h
DISTANCE 99 km

Average Vehicle Speed and Driving Distance

Average vehicle speed and driving distance from when the values were last reset until when they are next reset are displayed.

ELAPSED 999:59 min
DISTANCE 99 km

Elapsed Time and Driving Distance

Elapsed time and driving distance from when the values were last reset until when they are next reset is displayed.



NOTE

- The displayed values of fuel economy (average fuel economy), average vehicle speed, driving distance, and elapsed time can be reset on each screen by pressing and holding the MID mode R switch or MID mode L switch.

RANGE 200 km

Range (Possible Driving Range)

Displays the estimated maximum distance that can be driven with the remaining fuel quantity.





NOTE

- It may not always be possible to actually drive the displayed distance because it is calculated based on the past fuel economy (average fuel economy).
- Since the fuel in the fuel tank moves when going uphill and downhill, the accuracy of the displayed distance may decrease greatly.
- The display may not be updated when only a small amount of fuel is added to the tank.

Diesel Particulate Defuser (DPD) State







This function displays the amount of particulate matter (PM) accumulated in the DPD. During DPD regeneration, the progress of the regeneration is displayed.

Message	Display indication	Display condition
DPD PM level		The current level of PM accumulation in DPD is displayed.
Progress of DPD regeneration		The progress of DPD regeneration is displayed until it is completed.

DPD PM Level

The multi-information display (MID) shows the amount of PM accumulated in the DPD in six levels.







As the amount of PM in the DPD increases, the number of the displayed segments increases one by one from the left side ("L").

Status	Display	Status	Display
Level 0		Level 3	
Level 1		Level 4	
Level 2		Level 5	

Progress of DPD Regeneration

During DPD regeneration, the MID indicates the progress in six steps.

As regeneration progresses, the number of displayed segments decreases one by one from the right side ("H").

Status	Display	Status	Display
Regeneration progressed to 1st step		Regeneration progressed to 4th step	
Regeneration progressed to 2nd step		Regeneration progressed to 5th step	
Regeneration progressed to 3rd step		Regeneration complete	

Illumi Level

If "MANUAL" mode is selected as the setting for the "ILLUMI MODE" in "SELECT MODE", "ILLUMI LEVEL" will be displayed in the MID. The meter and MID can be individually set to six brightness levels. Adjust the brightness as desired by pressing the MID mode R switch or MID mode L switch.

Select Mode → Refer to page 4-45

••▶ : MID mode R switch/MID mode L switch - press and hold

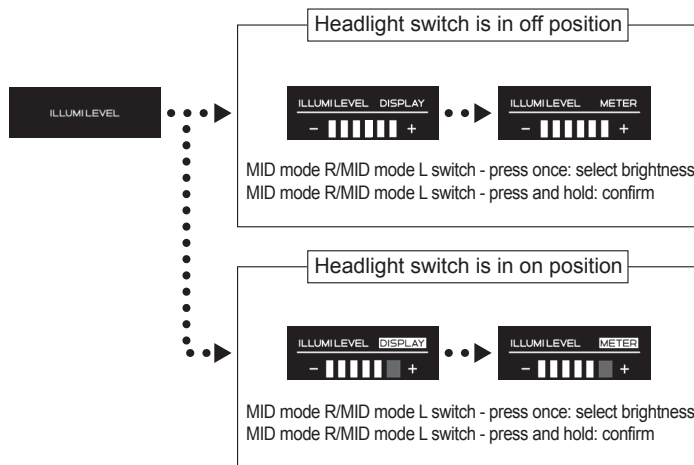

CAUTION

- When the headlights are turned on during daytime driving with the "MANUAL" mode setting, the MID may be dark and difficult to see.



NOTE

- If "AUTO" mode is selected as the setting for the "ILLUMI MODE" in "SELECT MODE", "ILLUMI LEVEL" will not be displayed in the MID main routine.

Select Mode → Refer to page 4-45

MID Main Routine → Refer to page 4-37

Select Mode

Press the MID mode R switch or MID mode L switch to display the "SELECT MODE" screen. With "SELECT MODE", the unit, maintenance distance, customize setting, calendar (only for vehicles with a factory-equipped audio system), clock (only for vehicles without a factory-equipped audio system), illumination mode, etc. are displayed, and their settings can be changed. To change setting, press the MID mode R switch or MID mode L switch and select the desired screen or function, then press and hold the MID mode R switch or MID mode L switch to display the setting screen.





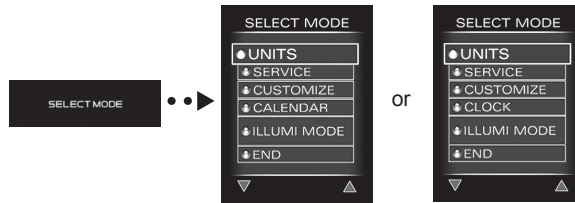

MID Main Routine → Refer to page 4-37

- ▶ : MID mode R switch/MID mode L switch - press and hold



NOTE

- Press the MID mode R switch or MID mode L switch, select "END" and press and hold the switch to return to the "SELECT MODE" entry screen. If no operation is performed on the screen for approximately 60 seconds, the screen automatically will return to the "SELECT MODE" entry screen. Also, when the vehicle starts to be driven, the screen will automatically return to the odometer display.
- The "SELECT MODE" can be operated only while the vehicle is stationary. When operating the "SELECT MODE", park your vehicle in a safe place where stopping or parking is permitted and is well clear of traffic.

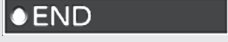
Display indication	Purpose	Reference page
	Set a fuel economy unit and outside temperature unit.	4-47
	Set the distance for a reminder for "ENGINE OIL", "AIR CLEANER ELEMENT" and "MAINTENANCE".	4-48 4-49 4-50
	Set the message display on/off, fuel economy display type, and vehicle image display type.	4-52 4-53 4-54 4-55
 *1	Set the calendar display on/off and the date setting.	4-56
 *2	Set the clock display on/off and the time setting.	4-58
	Change the adjustment method and adjustment sensitivity for MID illumination brightness.	4-60
	Return to the "SELECT MODE" entry screen.	4-61

*1: Vehicles with a factory-equipped audio system.

*2: Vehicles without a factory-equipped audio system.

UNITS (Fuel Economy Unit Setting)

With "FUEL CONS.", a unit of the fuel economy display can be changed to the desired unit among "km/l", "l/100km" or "mpg". Press the MID mode R switch or MID mode L switch to select, and press and hold the switch to set.

••▶ : MID mode R switch/MID mode L switch - press and hold

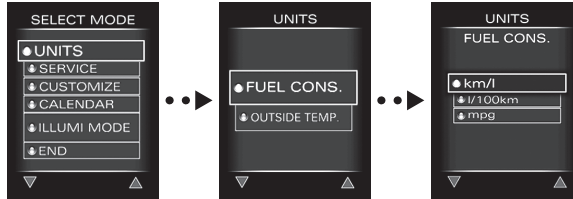

UNITS (Outside Temperature Unit Setting)

With "OUTSIDE TEMP.", a unit of the outside temperature display can be changed to either "°C" or "°F" temperature. Press the MID mode R switch or MID mode L switch to select, and press and hold the switch to set.

••▶ : MID mode R switch/MID mode L switch - press and hold

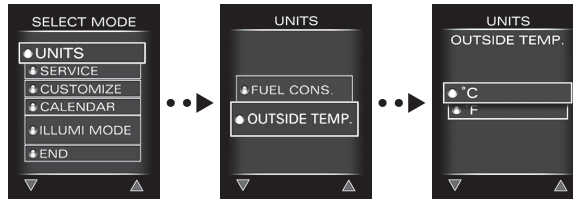

SERVICE (Engine Oil Reminder Distance Setting)

With "ENGINE OIL", the reminder setting for the replacement time of the engine oil can be set from 5,000 km (3,000 miles) to 20,000 km (12,000 miles). Increments of 2,500 km (1,500 miles) can be set between 5,000 km (3,000 miles) and 15,000 km (9,000 miles). Press the MID mode R switch or MID mode L switch to select, and press and hold the switch to set.

- ▶ : MID mode R switch/MID mode L switch - press and hold

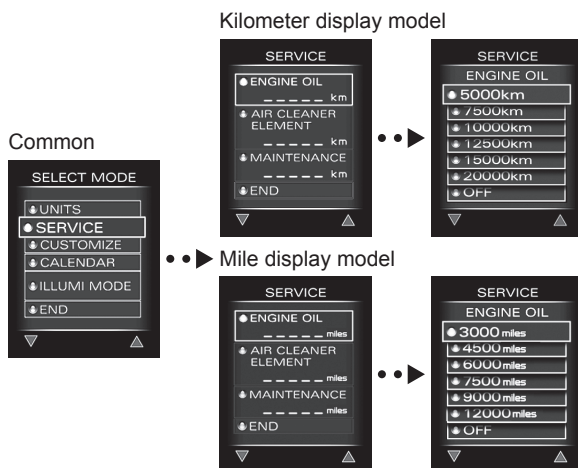
**NOTE**

- If you select "OFF" in the engine oil reminder distance setting screen, no reminder messages will be displayed.
- Once 1,000 km (600 miles) remain until the engine oil reminder distance, when the power mode is switched to "ON" (models with passive entry and start system) or the starter switch is turned to the "ON" position (models without passive entry and start system), the engine oil reminder screen will be displayed for approximately 3 seconds. Every 200 km (100 miles) after that, the engine oil reminder screen will be displayed again when the power mode is switched to "ON" (models with passive entry and start system) or the starter switch is turned to the "ON" position (models without passive entry and start system).
- If you press the MID mode R switch or MID mode L switch while the engine oil reminder screen is displayed, the "SERVICE REMINDER OFF" screen will be displayed. After that, reminder messages will no longer be displayed but the remaining engine oil reminder distance will still be calculated without being cleared.
- By selecting the engine oil reminder distance again, the current engine oil reminder distance is cleared and the calculation begins again.

SERVICE (Air Cleaner Element Reminder Distance Setting)

With "AIR CLEANER ELEMENT", the reminder setting for the replacement time of the air cleaner element can be set by 5,000 km (3,000 miles) from 20,000 km (12,000 miles) to 40,000 km (24,000 miles). Press the MID mode R switch or MID mode L switch to select, and press and hold the switch to set.

- ▶ : MID mode R switch/MID mode L switch - press and hold

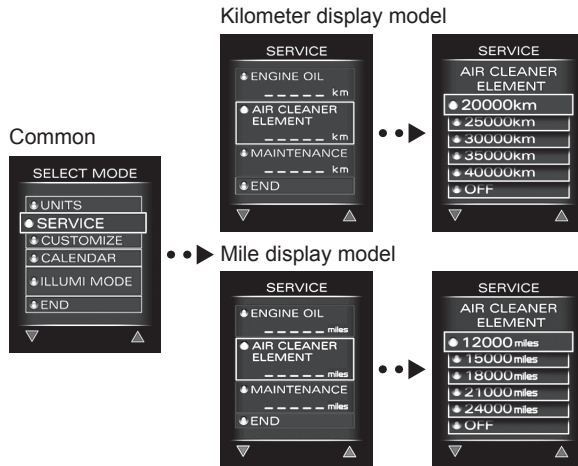

NOTE

- If you select "OFF" in the air cleaner element reminder distance setting screen, no reminder messages will be displayed.
- Once 1,000 km (600 miles) remain until the air cleaner element reminder distance, when the power mode is switched to "ON" (models with passive entry and start system) or the starter switch is turned to the "ON" position (models without passive entry and start system), the air cleaner element reminder screen will be displayed for approximately 3 seconds. Every 200 km (100 miles) after that, the air cleaner element reminder screen will be displayed again when the power mode is switched to "ON" (models with passive entry and start system) or the starter switch is turned to the "ON" position (models without passive entry and start system).
- If you press the MID mode R switch or MID mode L switch while the air cleaner element reminder screen is displayed, the "SERVICE REMINDER OFF" screen will be displayed. After that, reminder messages will no longer be displayed but the remaining air cleaner element reminder distance will still be calculated without being cleared.
- By selecting the air cleaner element reminder distance again, the current air cleaner element reminder distance is cleared and the calculation begins again.

SERVICE (Maintenance Reminder Distance Setting)

With "MAINTENANCE", the reminder setting for the maintenance reminder distance can be set by 1,000 km (600 miles) from 5,000 km (3,000 miles) to 20,000 km (12,000 miles). Press the MID mode R switch or MID mode L switch to select, and press and hold the switch to set.

"↵" or "⏪" is displayed in the reminder distance setting screen to indicate that there is a following or previous page. When "↵" or "⏪" appears, press the MID mode R switch or MID mode L switch to display the following or previous page.

••▶ : MID mode R switch/MID mode L switch - press and hold

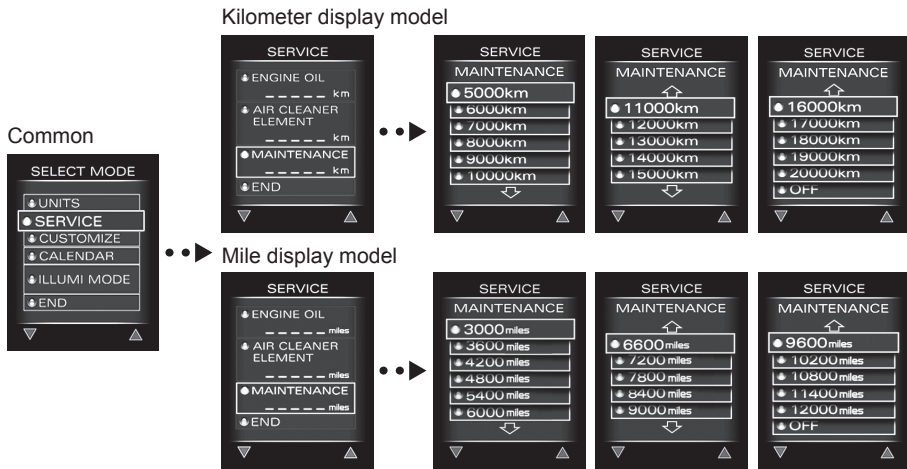

**NOTE**

- When you select "OFF" in the maintenance reminder distance setting screen, no reminder messages will be displayed.
- Once 1,000 km (600 miles) remain until the maintenance reminder distance, when the power mode is switched to "ON" (models with passive entry and start system) or the starter switch is turned to the "ON" position (models without passive entry and start system), the maintenance reminder screen will be displayed for approximately 3 seconds. Every 200 km (100 miles) after that, the maintenance reminder screen will be displayed again when the power mode is switched to "ON" (models with passive entry and start system) or the starter switch is turned to the "ON" position (models without passive entry and start system).
- If you press the MID mode R switch or MID mode L switch while the maintenance reminder screen is displayed, the "SERVICE REMINDER OFF" screen will be displayed. After that, reminder messages will no longer be displayed but the maintenance reminder distance will still be calculated without being cleared.
- By selecting the maintenance reminder distance again, the current maintenance reminder distance is cleared and the calculation begins again.

CUSTOMIZE (Message Display Setting)

With "STAND BY" in "MESSAGE", the image display on the MID for when the driver side door is opened and then closed can be selected when the power mode is in "OFF" (models with passive entry and start system) or when the starter switch is in the "LOCK" position (models without passive entry and start system). Press the MID mode R switch or MID mode L switch to select, and press and hold the switch to set.

- ▶ : MID mode R switch/MID mode L switch - press and hold

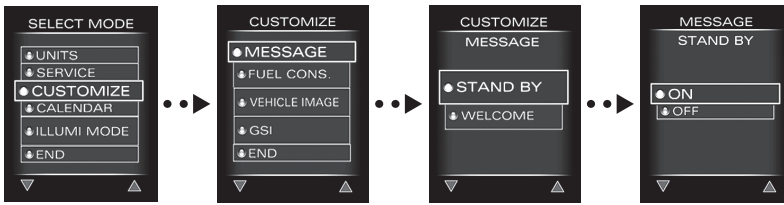

Mode	Setting	Image display
STAND BY	ON	On
	OFF	Off

With "WELCOME" in "MESSAGE", the preferred display setting for when the power mode is switched to "ON" or "OFF" (models with passive entry and start system) or when the starter switch is turned to the "ON", "START" or "LOCK" positions (models without passive entry and start system) can be selected. Press the MID mode R switch or MID mode L switch to select, and press and hold the switch to set.

- ▶ : MID mode R switch/MID mode L switch - press and hold

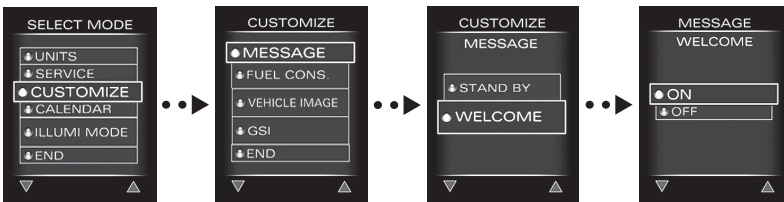

Mode	Setting	Message display (start up)	Pointer sweep (start up)	Message display (shut down)
WELCOME	ON	On	On	On
	OFF	Off	Off	Off

CUSTOMIZE (Fuel Economy Display Type Setting)

With "FUEL CONS.", the display type of the fuel economy display can be changed to the desired type. Press the MID mode R switch or MID mode L switch to select, and press and hold the switch to set.

- ▶ : MID mode R switch/MID mode L switch - press and hold

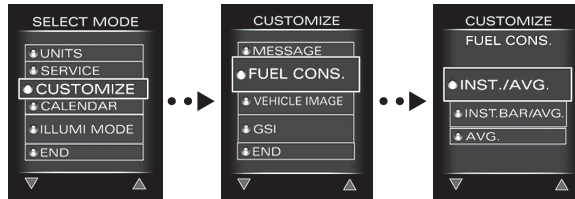



CUSTOMIZE (Vehicle Image Type Setting)

With "VEHICLE IMAGE", the vehicle image type displayed in "MESSAGE" when the "STAND BY" setting is "ON" can be selected. Press the MID mode R switch or MID mode L switch to select, and press and hold the switch to set.

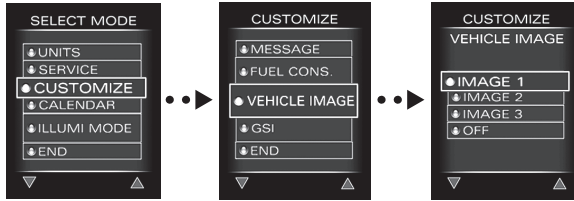
••▶ : MID mode R switch/MID mode L switch - press and hold



Setting	Display indication	Description
IMAGE 1*		Crew cab image is displayed.
IMAGE 2		Extended cab image is displayed.
IMAGE 3		Regular cab image is displayed.

*: Factory default settings

CUSTOMIZE (Gear Shift Indicator Display Setting)

With "GSI", the gear shift indicator (GSI) display can be turned on or off. Press the MID mode R switch or MID mode L switch to select, and press and hold the switch to set.

- ▶ : MID mode R switch/MID mode L switch - press and hold

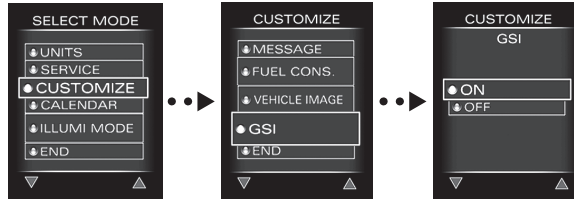
**NOTE**

- When "ON" is selected for the GSI setting, it is also possible to set the display so that it only displays the current gear position (without displaying the recommended gear position) using the following procedure:
 - 1) Switch the power mode to "ON" (models with passive entry and start system) or turn the starter switch to the "ON" position (models without passive entry and start system) while pressing the MID mode R switch or MID mode L switch.
 - 2) Insert the latch plate and remove it from the driver side seat belt buckle three times within approximately 7 seconds.
 To display the recommended gear position again, repeat the above procedure.

CALENDAR (Calendar Display and Date Setting)

With "CALENDAR", the calendar display on/off and date can be set.

1. In the "SELECT MODE", select "CALENDAR" and then press and hold the MID mode R switch or MID mode L switch.
2. Press the MID mode R switch or MID mode L switch, select "ON" or "OFF" for the calendar display, and then press and hold the MID mode R switch or MID mode L switch to configure the setting.
 - Selecting "ON" will turn on the calendar display and the MID will switch to the settings for the calendar and clock (step 3).
 - Selecting "OFF" will turn off the calendar display and the MID will return to the "SELECT MODE".

**NOTE**

- The unit that can be set will be indicated in green. Upon being set, the color of the unit will change from green to white.

3. Press the MID mode R switch or MID mode L switch, select the year, and then press and hold the MID mode R switch or MID mode L switch to configure the setting. Once the year has been configured, it will be possible to adjust the month.
4. Press the MID mode R switch or MID mode L switch, select the month, and then press and hold the MID mode R switch or MID mode L switch to configure the setting. Once the month has been configured, it will be possible to set the date (in units of 10 days).
5. Press the MID mode R switch or MID mode L switch, select the date (in units of 10 days), and then press and hold the MID mode R switch or MID mode L switch to configure the setting. Once the date (in units of 10 days) has been configured, it will be possible to set the date (in units of single day).
6. Press the MID mode R switch or MID mode L switch, select the date (in units of single day), and then press and hold the MID mode R switch or MID mode L switch to configure the setting. Once the date (in units of single day) has been configured, it will be possible to set the hour (time setting).
7. Press the MID mode R switch or MID mode L switch, select the hour, and then press and hold the MID mode R switch or MID mode L switch to configure the setting. Once the hour has been configured, it will be possible to set the minute (in units of 10 minutes).
8. Press the MID mode R switch or MID mode L switch, select the minute (in units of 10 minutes), and then press and hold the MID mode R switch or MID mode L switch to configure the setting. Once the minute (in units of 10 minutes) has been configured, it will be possible to set the minute (in units of single minute).

9. Press the MID mode R switch or MID mode L switch, select the minute (in units of single minute), and then press and hold the MID mode R switch or MID mode L switch to configure the setting. Once the minute (in units of single minute) has been configured, upon displaying the configured time, the MID will return to the "SELECT MODE".

••▶ : MID mode R switch/MID mode L switch - press and hold

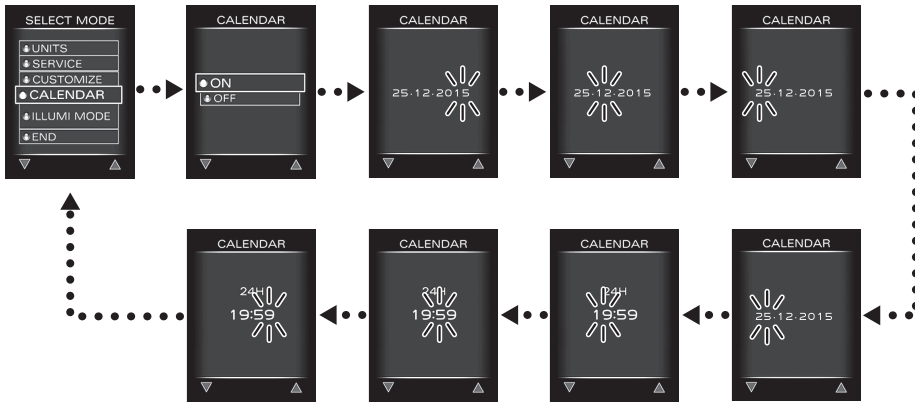

CLOCK (Clock Display and Time Setting)

With "CLOCK", the clock display on/off and time can be set.

1. In the "SELECT MODE", select "CLOCK" and then press and hold the MID mode R switch or MID mode L switch.
2. Press the MID mode R switch or MID mode L switch, select "ON" or "OFF" for the clock display, and then press and hold the MID mode R switch or MID mode L switch to configure the setting.
 - Selecting "ON" will turn on the clock display and the MID will switch to the settings for the clock (step 3).
 - Selecting "OFF" will turn off the clock display and the MID will return to the "SELECT MODE".
3. Press the MID mode R switch or MID mode L switch, select "12H" or "24H" for the display method of the clock, and then press and hold the MID mode R switch or MID mode L switch to configure the setting. Once the display method has been configured, it will be possible to set the hour.

**NOTE**

- The unit that can be set will be indicated in green. Upon being set, the color of the unit will change from green to white.

4. Press the MID mode R switch or MID mode L switch, select the hour, and then press and hold the MID mode R switch or MID mode L switch to configure the setting. Once the hour has been configured, it will be possible to set the minute (in units of 10 minutes).
5. Press the MID mode R switch or MID mode L switch, select the minute (in units of 10 minutes), and then press and hold the MID mode R switch or MID mode L switch to configure the setting. Once the minute (in units of 10 minutes) has been configured, it will be possible to set the minute (in units of single minute).
6. Press the MID mode R switch or MID mode L switch, select the minute (in units of single minute), and then press and hold the MID mode R switch or MID mode L switch to configure the setting. Once the minute (in units of single minute) has been configured, upon displaying the configured time, the MID will return to the "SELECT MODE".

••► : MID mode R switch/MID mode L switch - press and hold

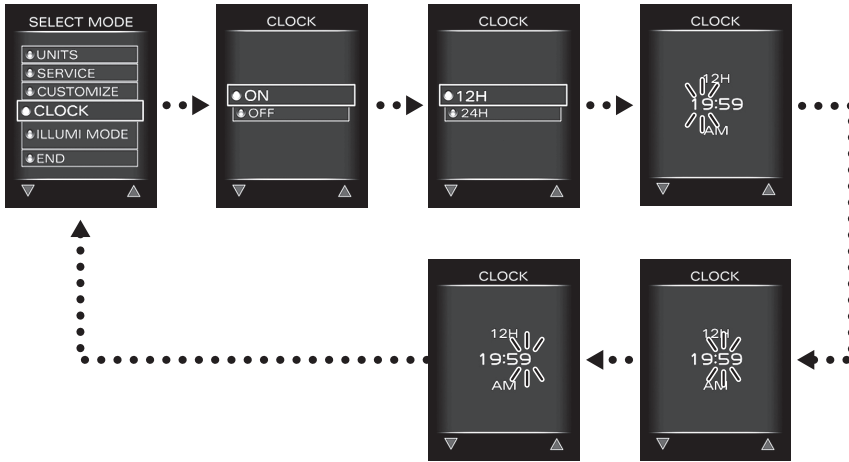

ILLUMI MODE

With "ILLUMI MODE", the adjustment method for MID illumination brightness can be changed. In "AUTO" mode, the illumination brightness is automatically adjusted according to the brightness inside the vehicle. In "MANUAL" mode, the meter and MID can be individually set to six brightness levels. Press the MID mode R switch or MID mode L switch to select, and press and hold the switch to set.

Illumi Level → Refer to page 4-44

- ▶ : MID mode R switch/MID mode L switch - press and hold

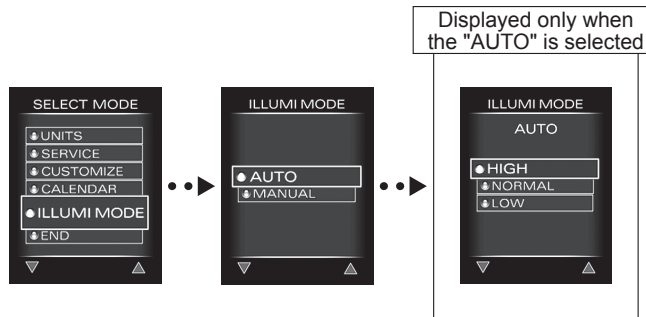
**NOTE**

- The factory default setting is "NORMAL" under "AUTO".
- In the "HIGH" setting of the "AUTO" mode, the illumination brightness changes with high sensitivity. The sensitivity of "NORMAL" is between "HIGH" and "LOW". "LOW" changes with low sensitivity. The factory default setting is "NORMAL".
- When "AUTO" mode is used after the brightness has been adjusted in "MANUAL" mode, the illumination will be automatically adjusted based on the brightest state with the headlight switch in the off position setting for the "MANUAL" mode and the darkest state with the headlight switch in the on position setting.

END

Select "END" and press and hold the MID mode R switch or MID mode L switch to return to the "SELECT MODE" entry screen.

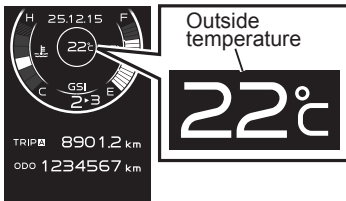
Outside Temperature Display**Manual transmission model**

Outside temperatures between -40°C (-40°F) and 50°C (122°F) are displayed on the MID.

**NOTE**

- The displayed temperature may be different from the actual temperature depending on the surrounding conditions, the driving conditions, etc.

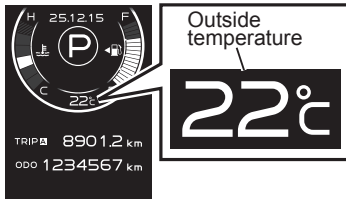
Automatic transmission model

Liquid Crystal Display (LCD)

Liquid crystal display
(LCD)

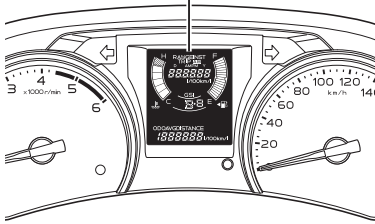

The LCD in the instrument panel can display the following information.

- Engine coolant temperature gauge
- Fuel gauge
- Odometer
- Trip meter
- Fuel economy
- Range (possible driving range)
- Calendar/clock
- Gear shift indicator (GSI) (manual transmission model)
- Shift indicator (automatic transmission model)

Use the trip knob to select the desired display or function.

Manual transmission model



Automatic transmission model



LCD Main Routine

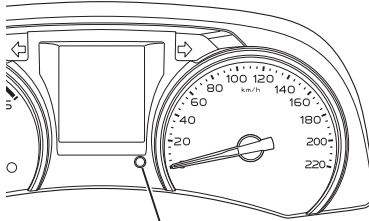

Trip knob

Basic operation and the screens of the LCD are shown.

Use the trip knob to select the desired display or function.

→ : Trip knob - press once

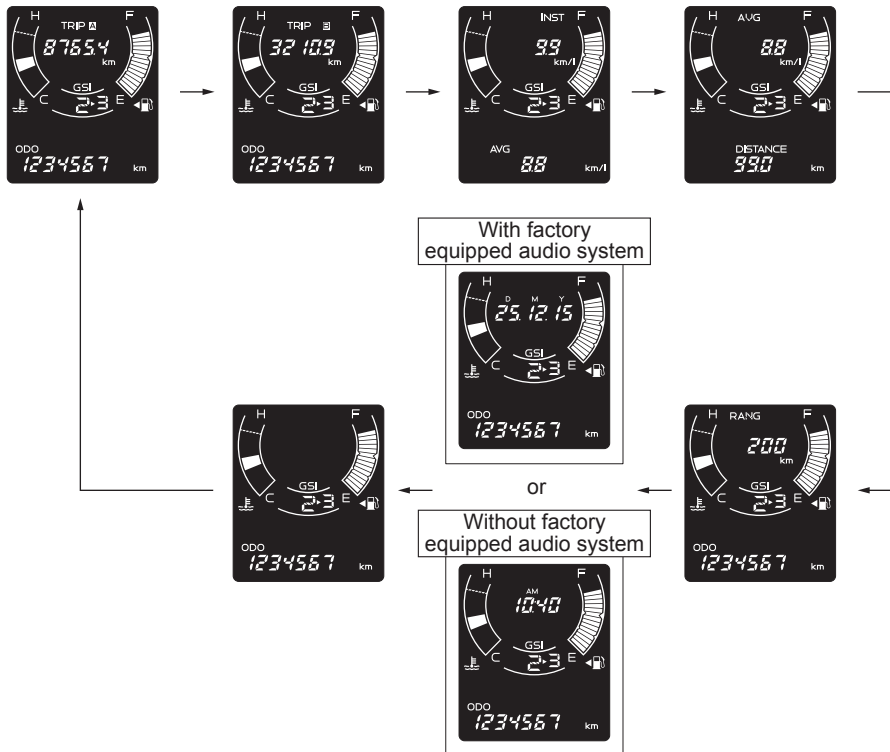

Operation-Related Information Display

The operating conditions and operating control information of fuel economy, driving distance, and range (possible driving range) are displayed.



NOTE

- The system calculates and stores the distance traveled and fuel consumption while driving to encourage the operator to drive the vehicle economically.
- The operation-related information display may differ from the actual values due to the conditions of roads, wind, cargo weight, number of passengers, the rear body, etc. Use the indications only as guidelines.
- The unit of distance is indicated using "km" if the speedometer is graduated in kilometer units. The unit of distance is indicated using "miles" if the speedometer is graduated in both mile and kilometer units.

Fuel Economy

Fuel consumption of the driving distance ("DISTANCE") section is displayed.

Display types can be changed by pressing the trip knob.

Message	Display indication	Description
Instantaneous fuel economy and average fuel economy		Instantaneous fuel economy ("INST") and average fuel economy ("AVG") are indicated in figures.
Average fuel economy and driving distance		Average fuel economy ("AVG") and driving distance ("DISTANCE") are indicated in figures.

**NOTE**

- In the fuel economy display, the displayed units of measurement can be switched between "km/l", "l/100km" and "mpg". To change the unit of measurement, press and hold the trip knob while the instantaneous fuel economy ("INST") and average fuel economy ("AVG") is displayed. Then, press the trip knob to select the desired unit. To complete selection of the unit, press and hold the trip knob.
- The displayed values for "AVG" and "DISTANCE" can reset by pressing and holding the trip knob when the "AVG" and "DISTANCE" is displayed.

**Driving Distance**

Driving distance from when the value was last reset until it is next reset is displayed.

**NOTE**

- The displayed values for "AVG" and "DISTANCE" can reset by pressing and holding the trip knob when the "AVG" and "DISTANCE" is displayed.

**Range (Possible Driving Range)**

Displays the estimated maximum distance that can be driven with the remaining fuel quantity.

**NOTE**

- It may not always be possible to actually drive the displayed distance because it is calculated based on the past fuel economy (average fuel economy).
- Since the fuel in the fuel tank moves when going uphill and downhill, the accuracy of the displayed distance may decrease greatly.
- The display may not be updated when only a small amount of fuel is added to the tank.

Calendar (Calendar and Time Setting)

1. On the LCD, selecting calendar display and then pressing and holding the trip knob will make it possible to set the year.

**NOTE**

- The unit that can be set will flash. Upon being set, the state of the unit will change from flashing to continuously illuminated.

2. Press the trip knob, select the year, and then press and hold the trip knob to configure the setting. Once the year has been configured, it will be possible to set the month.
3. Press the trip knob, select the month, and then press and hold the trip knob to configure the setting. Once the month has been configured, it will be possible to set the date (in units of 10 days).
4. Press the trip knob, select the date (in units of ten days), and then press and hold the trip knob to configure the setting. Once the date (in units of 10 days) has been configured, it will be possible to set the date (in units of single day).
5. Press the trip knob, select the date (in units of single day), and then press and hold the trip knob to configure the setting. Once the date (in units of single day) has been configured, it will be possible to set the hour (time setting).
6. Press the trip knob, select the hour, and then press and hold the trip knob to configure the setting. Once the hour has been configured, it will be possible to set the minute (in units of 10 minutes).
7. Press the trip knob, select the minute (in units of 10 minutes), and then press and hold the trip knob to configure the setting. Once the minute (in units of 10 minutes) has been configured, it will be possible to set the minute (in units of single minute).
8. Press the trip knob, select the minute (in units of single minute), and then press and hold the trip knob to configure the setting. Once the minute (in units of single minute) has been configured, upon displaying the configured time, the LCD will return to the calendar display.

••► : Trip knob - press and hold



Clock (Time Setting)

1. On the LCD, selecting clock display and then pressing and holding the trip knob will make it possible to set the display method of the clock.

**NOTE**

- The unit that can be set will flash. Upon being set, the state of the unit will change from flashing to continuously illuminated.
2. Press the trip knob, select "12:h" or "24:h" for the display method of the clock, and then press and hold the trip knob to configure the setting. Once the display method has been configured, it will be possible to set the hour.
 3. Press the trip knob, select the hour, and then press and hold the trip knob to configure the setting. Once the hour has been configured, it will be possible to set the minute (in units of 10 minutes).
 4. Press the trip knob, select the minute (in units of 10 minutes), and then press and hold the trip knob to configure the setting. Once the minute (in units of 10 minutes) has been configured, it will be possible to set the minute (in units of single minute).
 5. Press the trip knob, select the minute (in units of single minute), and then press and hold the trip knob to configure the setting. Once the minute (in units of single minute) has been configured, upon displaying the configured time, the LCD will return to the clock display.

••► : Trip knob - press and hold

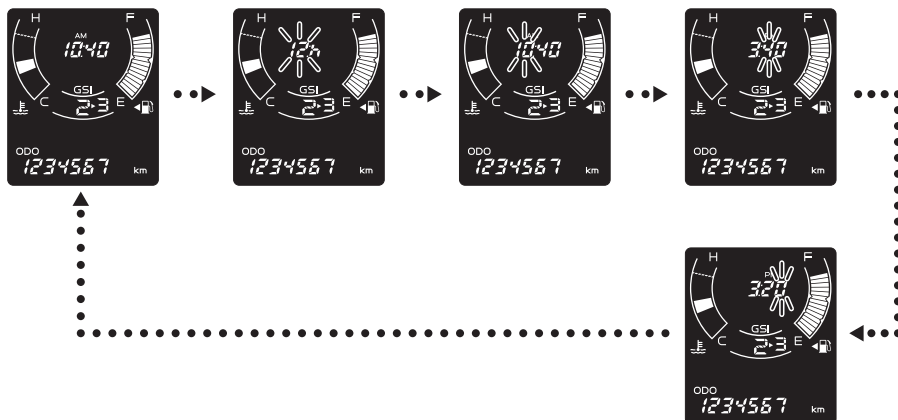

••► : Trip knob - press and hold

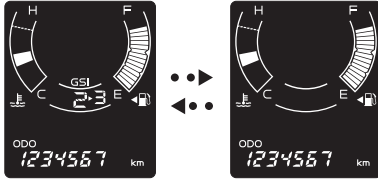

GSI (Gear Shift Indicator)

Set the gear shift indicator (GSI) display on/off. The gear shift indicator display can be turned on and off by pressing and holding the trip knob.



NOTE

- When the GSI display is on, it is also possible to set the display so that it only displays the current gear position (without displaying the recommended gear position) using the following procedure:
 - 1) Turn the starter switch to the "ON" position while pressing the trip knob.
 - 2) Insert the latch plate and remove it from the driver side seat belt buckle three times within approximately 7 seconds. To display the recommended gear position again, repeat the above procedure.

Warning and Indicator Lights

Seat Belt Warning Light (Driver Seat)

**Models with Side Airbag and Curtain Airbag**

This warning light flashes when the driver is not wearing the seat belt while the power mode is "ON" (models with passive entry and start system) or the starter switch is in the "ON" position (models without passive entry and start system).

A buzzer will sound if the vehicle continues to be driven while the warning light is flashing.

**NOTE**

- The warning light will go out and the buzzer will stop sounding as soon as the driver has buckled the seat belt.

**Models without Side Airbag and Curtain Airbag**

This warning light comes on when the driver is not wearing the seat belt while the power mode is "ON" (models with passive entry and start system) or the starter switch is in the "ON" position (models without passive entry and start system).

**NOTE**

- The warning light will go out as soon as the driver has buckled the seat belt.

Seat Belt Warning Light (Front Passenger Seat)**Models with Side Airbag and Curtain Airbag**

This warning light flashes when a passenger is in the front passenger seat without wearing the seat belt while the power mode is "ON" (models with passive entry and start system) or the starter switch is in the "ON" position (models without passive entry and start system).

A buzzer will sound if the vehicle continues to be driven while the warning light is flashing.

**NOTE**

- The warning light will go out and the buzzer will stop sounding as soon as the passenger has buckled the seat belt.
- Operation of the front passenger seat sensor:
 - The seat belt warning may be activated even when there are no passengers due to the sensor detecting weight if objects are placed on the passenger seat.
 - The seat belt warning may not be activated when the sensor does not detect passengers due to a cushion, etc., being placed on the seat.

SRS Airbag Warning Light



The SRS airbag warning light should flash seven times when the power mode is switched to "ON" (models with passive entry and start system) or the starter switch is turned to the "ON" position (models without passive entry and start system), and then should go out.

If the SRS airbag warning light comes on, seat belt with pretensioner and airbag may not function properly in the event of a collision.

 **WARNING**

- If you encounter any of the following conditions, errors have occurred. Have your vehicle inspected/serviced at your Isuzu Dealer as soon as possible.

[System error]

- If the SRS airbag warning light does not flash seven times when the power mode is switched to "ON" (models with passive entry and start system) or the starter switch is turned to the "ON" position (models without passive entry and start system).
- If the SRS airbag warning light does not go out.
- If the SRS airbag warning light comes on while driving the vehicle.

 **NOTE**

- It is normal for the warning light to come on, flash seven times, and then go out when the power mode is switched to "ON" (models with passive entry and start system) or the starter switch is turned to the "ON" position (models without passive entry and start system). The SRS airbag warning light may come on again immediately after the engine is started, but it is normal if it goes out after flashing seven times.
- The SRS airbag warning light may come on suddenly if the power mode is switched to "ACC" (models with passive entry and start system), the starter switch is turned to the "ACC" position (models without passive entry and start system), or electrical equipment is operated, but this is not abnormal.

Brake System/Parking Brake Warning Light**Brake System Warning Light**

This warning light will come on when the power mode is switched to "ON" (models with passive entry and start system) or the starter switch is turned to the "ON" position (models without passive entry and start system) with the parking brake released. If there is no malfunction, the light will then go out after the engine is started.

The brake system warning light comes on while the engine is running (after startup) in the following situations:

- Drop in the level of brake fluid (due to brake wear or fluid leakage, etc.)
- Abnormality in the EBD (the ABS warning light will also come on.)

ABS Warning Light

→ Refer to page 4-75

**CAUTION**

- If this warning light comes on while the engine is running, immediately stop your vehicle at a safe place well clear of traffic and promptly contact the nearest Isuzu Dealer for inspection.
- Immediately stop your vehicle at a safe place and contact your Isuzu Dealer when the ABS warning light and brake system warning light both remain on. The indications mean that the ABS will fail and vehicle will become extremely unstable during braking. Also the rear brakes may lock up more easily than usual in emergency braking. This could result in an accident.



Parking Brake Warning Light

This warning light comes on when the parking brake lever is pulled up.



CAUTION

- The illumination of the warning light does not necessarily ensure firm application of the parking brake. The parking brake lever must be sufficiently pulled up and locked.
- Be careful not to drive the vehicle with the parking brake lever still pulled up.

Parking Brake Release Warning Light



Models with MID

If the vehicle is driven without releasing the parking brake and the speed reaches approximately 5 km/h (3.1 MPH), this message appears on the display while a buzzer sounds. When the parking brake release warning light is indicated, release the parking brake.

Warning Buzzer → Refer to page 4-111

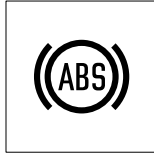
ABS Warning Light

This warning light should come on when the power mode is switched to "ON" (models with passive entry and start system) or the starter switch is turned to the "ON" position (models without passive entry and start system), and then should go out after approximately 3 seconds.

This warning light comes on whenever there is a problem in the anti-lock brake system (ABS). In this case, the ABS stops working but the brakes still function as ordinary service brakes.

**CAUTION**

- If this warning light comes on while driving, immediately stop your vehicle at a safe place well clear of traffic and take the following actions.
 - Stop the engine.
 - Restart the engine. Check if the ABS warning light comes on and then goes out. If it does, there is no problem. The ABS operates normally.
 - Move the vehicle slowly forward. Gradually increase the speed to 15 km/h (9 MPH). If the light goes off, the ABS is normal.
- Immediately stop your vehicle at a safe place and contact your Isuzu Dealer when the ABS warning light and brake system warning light both remain on. The indications mean that the ABS will fail and vehicle will become extremely unstable during braking. Also the rear brakes may lock up more easily than usual in emergency braking. This could result in an accident.
- If the warning light does not go out, or comes on repeatedly, have the vehicle inspected/serviced at the nearest Isuzu Dealer as soon as possible.
- Even if a problem has occurred in the ABS, the brakes will still work as normal brakes. In this case, the ABS has no influence on the operation of the brake system.

Anti-lock Brake System (ABS)

→ Refer to page 4-158

ESC Warning Light



When the power mode is switched to "ON" (models with passive entry and start system) or the starter switch is turned to the "ON" position (models without passive entry and start system), the ESC warning light turns on before going out after approximately 3 seconds. This warning light comes on whenever there is a problem in the electronic stability control (ESC) and/or hill descent control. When the ESC is operating, the ESC warning light flashes. The ESC warning light will also flash when only the traction control system (TCS) function is operating inside the ESC system.

When the ESC warning light does any of the following, the ESC may be faulty. Please contact the nearest Isuzu Dealer.

- When the ESC warning light remains on while driving.
- The ESC warning light does not turn on when the power mode is switched to "ON" (models with passive entry and start system) or the starter switch is turned to the "ON" position (models without passive entry and start system).

**NOTE**

- When the ESC warning light is on, the TCS/ESC will not operate, but this has no effect on normal driving.
- The ESC warning light may turn on when the battery cables are disconnected or the battery voltage is low. The ESC function turns off while the ESC warning light is on, but the ESC warning light will turn off by driving the vehicle normally for a while, then the ESC function will resume. If the ESC warning light remains on even after driving for a while, contact the nearest Isuzu Dealer.

Electronic Stability Control (ESC)

→ Refer to page 4-163

Hill Descent Control

→ Refer to page 4-172

Engine Oil Pressure Warning Light



This warning light should come on when the power mode is switched to "ON" (models with passive entry and start system) or the starter switch is turned to the "ON" position (models without passive entry and start system), and then should go out after the engine is started.

While the engine is running, this warning light comes on if the engine oil pressure, which lubricates the engine components, is abnormal.



ADVICE

- If this warning light comes on while the engine is running, immediately pull off to a safe place well clear of traffic. Stop the engine immediately and check the engine oil level.
- The lubrication system may be faulty. Promptly have your vehicle inspected at the nearest Isuzu Dealer.

Engine Oil → Refer to page 6-20

Engine Overheat Warning Light

Models with MID



Models with LCD



This warning light comes on when the engine overheats. When the engine overheats, the engine coolant temperature gauge will indicate "H" zone and flash, the engine overheat warning light will come on, and the engine overheat warning buzzer will sound. Immediately pull off the road in a safe place, check the vehicle and take necessary actions.

In models with an LCD, this warning light should come on when the starter switch is turned to the "ON" position, and then should go out after approximately 3 seconds.

WARNING

- When the engine coolant is still hot, do not remove the radiator cap. Hot vapor will come out and you may be scalded. Add engine coolant only when the engine coolant temperature has dropped.

CAUTION

- If you continue to drive the vehicle with the engine overheat warning light on steady, the engine may seize up.

ADVICE

- Do not shut down an overheating engine immediately. Otherwise, the engine may seize up. Take appropriate actions for engine overheating.

Warning Buzzer → Refer to page 4-111

Adding the Engine Coolant

→ Refer to page 6-44

When the Engine Overheats

→ Refer to page 7-32

Engine Oil Indicator Light



Models with MID

This message appears when the maintenance time is set on the "SERVICE" screen of "SELECT MODE". This message appears on the display when the engine oil maintenance reminder distance will soon be reached. The distance shown is the remaining distance to the next engine oil change time or the distance the vehicle traveled after the due time.

When the maintenance reminder distance will soon be reached, this message appears after the power mode is switched to "ON" (models with passive entry and start system) or the starter switch is turned to the "ON" position (models without passive entry and start system) and remains on for approximately 3 seconds. When the engine oil indicator light is indicated on the multi information display, have the vehicle inspected/serviced at the nearest Isuzu Dealer.



NOTE

- The unit of distance is indicated using "km" if the speedometer is graduated in kilometer units. The unit of distance is indicated using "miles" if the speedometer is graduated in both mile and kilometer units.

Multi-Information Display (MID)

→ Refer to page 4-30

Engine Oil

→ Refer to page 6-20

Air Cleaner Element Indicator Light

**Models with MID**

This message appears when the maintenance time is set on the "SERVICE" screen of "SELECT MODE". This message appears on the display when the air cleaner element maintenance reminder distance will soon be reached. The distance shown is the remaining distance to the next air cleaner element change time or the distance the vehicle traveled after the due time.

When the maintenance reminder distance will soon be reached, this message appears after the power mode is switched to "ON" (models with passive entry and start system) or the starter switch is turned to the "ON" position (models without passive entry and start system) and remains on for approximately 3 seconds. When the air cleaner element indicator light is indicated on the multi information display, have the vehicle inspected/serviced at the nearest Isuzu Dealer.

**NOTE**

- The unit of distance is indicated using "km" if the speedometer is graduated in kilometer units. The unit of distance is indicated using "miles" if the speedometer is graduated in both mile and kilometer units.

Multi-Information Display (MID)

→ Refer to page 4-30

Air Cleaner

→ Refer to page 6-50

Distance to Maintenance Indicator Light



Models with MID

This message appears when the maintenance time is set on the "SERVICE" screen of "SELECT MODE". This message appears on the display when the maintenance reminder distance set by the user will soon be reached. The distance shown is the remaining distance to the next maintenance time or the distance the vehicle traveled after the due time. When the maintenance reminder distance will soon be reached, this message appears after the power mode is switched to "ON" (models with passive entry and start system) or the starter switch is turned to the "ON" position (models without passive entry and start system) and remains on for approximately 3 seconds. When the maintenance indicator light is indicated on the multi information display, have the vehicle inspected/serviced at the nearest Isuzu Dealer.



NOTE

- The unit of distance is indicated using "km" if the speedometer is graduated in kilometer units. The unit of distance is indicated using "miles" if the speedometer is graduated in both mile and kilometer units.

Multi-Information Display (MID)

→ Refer to page 4-30

Generator Warning Light

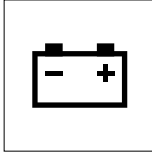

This warning light should come on when the power mode is switched to "ON" (models with passive entry and start system) or the starter switch is turned to the "ON" position (models without passive entry and start system), and then should go out after the engine is started.

This warning light comes on when, while the engine is running, there is a problem with the charging system (such as a loose or broken fan belt).



ADVICE

- If this warning light comes on while the engine is running, immediately pull off to a safe place well clear of traffic and promptly contact the nearest Isuzu Dealer for inspection.

Fan Belt/Air Conditioning Compressor Belt/Accessory Belt

→ Refer to page 6-47

Handling the Battery

→ Refer to page 6-101

When the Battery Goes Flat

→ Refer to page 7-26

Malfunction Indicator Light (MIL)

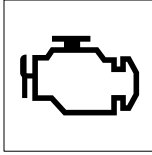

This indicator light should come on when the power mode is switched to "ON" (models with passive entry and start system) or the starter switch is turned to the "ON" position (models without passive entry and start system), and then should go out after the engine is started.

If this indicator light comes on while the engine is running, this alerts you to a problem with the engine electronic control system or the diesel particulate defuser (DPD). In addition, if this light does not turn on when the power mode is switched to "ON" (models with passive entry and start system) or the starter switch is turned to the "ON" position (models without passive entry and start system), an abnormality, etc., in the engine electronic control system is possible. Please contact the nearest Isuzu Dealer.



CAUTION

- If this indicator light comes on and the engine stops, it is possible that the engine has entered protection mode. Switch the power mode to "OFF" (models with passive entry and start system) or turn the starter switch to the "LOCK" position (models without passive entry and start system) and wait at least 10 seconds before proceeding to start the engine again. Even if the vehicle is drivable, see the nearest Isuzu Dealer as soon as possible for service of the system.



ADVICE

- If this indicator light comes on while the engine is running, avoid driving at high speeds and promptly have the vehicle inspected at the nearest Isuzu Dealer.
- If this indicator light comes on either intermittently or continuously while driving, service is required. Even if the vehicle is drivable, and does not require towing, see your Isuzu Dealer as soon as possible for service of the system. Continued driving without having the system serviced could cause damage to the emission control system. It could also affect fuel economy and drivability.

Diesel Particulate Defuser (DPD)

→ Refer to page 4-184

Service Vehicle Soon (SVS) Indicator Light

This indicator light should come on when the power mode is switched to "ON" (models with passive entry and start system) or the starter switch is turned to the "ON" position (models without passive entry and start system), and then should go out after the engine is started.

If the indicator light comes on during operation, immediately contact the nearest Isuzu Dealer for inspection.

Water Separator Warning Light

Water separator warning light

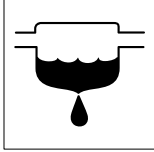

Warning message (models with MID)



This warning light should come on when the power mode is switched to "ON" (models with passive entry and start system) or the starter switch is turned to the "ON" position (models without passive entry and start system), and then should go out after approximately 3 seconds.

In models with an MID, when water in the water separator needs draining, the water separator warning light comes on after the warning message is displayed on the MID for approximately 3 seconds and then goes out.

In models with an LCD, when water in the water separator needs draining, the water separator warning light comes on.

Drain water following the instructions in the "Draining Water from the Fuel Filter" and make sure the warning light goes out.



CAUTION

- If this warning light comes on while the engine is running, immediately drain water from the fuel filter. If you still continue driving with the warning light on, the fuel injection system may fail.

Draining Water from the Fuel Filter

→ Refer to page 6-54

Bleeding the Fuel System

→ Refer to page 7-29

Fuel Filter Warning Light



This warning light should come on when the power mode is switched to "ON" (models with passive entry and start system) or the starter switch is turned to the "ON" position (models without passive entry and start system), and then should go out after approximately 3 seconds.

This warning light comes on when the fuel filter element clogged with dust and others. If this warning light comes on, have the vehicle inspected/serviced at your Isuzu Dealer as soon as possible.

Check Trans Warning Light

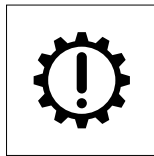

Automatic Transmission Model

This warning light should remain on for approximately 3 seconds after the power mode is switched to "ON" (models with passive entry and start system) or the starter switch is turned to the "ON" position (models without passive entry and start system), and then should go out.

If this light flashes after the engine has started, there is something wrong with the transmission electronic control system.



ADVICE

- If this warning light flashes, have the automatic transmission inspected at the nearest Isuzu Dealer as soon as possible.
- While the warning light is flashing, the computer may put the transmission into emergency mode.

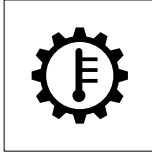
Automatic Transmission Fluid Temperature Warning Light

This warning light should remain on for approximately 3 seconds after the power mode is switched to "ON" (models with passive entry and start system) or the starter switch is turned to the "ON" position (models without passive entry and start system), and then should go out.

This warning light comes on when the temperature of the automatic transmission becomes high while driving.

**ADVICE**

- If this warning light comes on while driving, the automatic transmission fluid is abnormally hot. Immediately pull safely off the road out of the way of any traffic, place the selector lever in the "P" position and run the engine at idling speed. Do not start driving again until the warning light goes out.
- If this warning light does not go off, have the automatic transmission lubricating system inspected at the nearest Isuzu Dealer as soon as possible.

CHECK 4WD Warning Light**CHECK
4WD**

The CHECK 4WD warning light comes on when the power mode is switched to "ON" (models with passive entry and start system) or the starter switch is turned to the "ON" position (models without passive entry and start system) and should then go out after approximately 3 seconds. When this warning light stays on, the 4WD system has a malfunction. Please contact the nearest Isuzu Dealer.

**CAUTION**

- If the warning light does not go out, or comes on repeatedly, have the inspected/serviced at the nearest Isuzu Dealer as soon as possible.

Icy Road Warning Light

**Models with MID**

This warning light should come on when the power mode is switched to "ON" (models with passive entry and start system) or the starter switch is turned to the "ON" position (models without passive entry and start system), and then should go out after approximately 3 seconds.

This warning light comes on when the outside temperature is low and the road surface may be frozen. Since this is based on the outside temperature detected by the outside air temperature sensor and not the actual road surface temperature, it does not accurately display frozen road surface conditions.

**CAUTION**

- When the outside temperature is low, the road surface may be frozen even if the icy road warning light does not illuminate. Concentrate on driving safely, paying attention to the condition of the road surface.

Low Fuel Warning Light

Low fuel warning light



Warning message (models with MID)



This warning light should come on when the power mode is switched to "ON" (models with passive entry and start system) or the starter switch is turned to the "ON" position (models without passive entry and start system), and then should go out after approximately 3 seconds.

In models with an MID, when the fuel level in the tank becomes low while the engine is running, the low fuel warning light comes on after the warning message is displayed on the MID for approximately 3 seconds and then goes out.

In models with an LCD, when the fuel level in the tank becomes low while the engine is running, the low fuel warning light comes on.



ADVICE

- If the low fuel warning light comes on, add fuel at the earliest possible time.
- If the vehicle runs out of fuel, air bleeding procedure must be performed.

Fuel Gauge → Refer to page 4-23
When the Fuel Runs Out

→ Refer to page 7-28

Door Open Warning Light



The door open warning light comes on if any door is not fully closed when the power mode is switched to "ON" (models with passive entry and start system) or the starter switch is turned to the "ON" position (models without passive entry and start system).

Light Control OFF Warning Light



Models with MID

This message appears on the display when the light control switch is set to "☞" or "☜", the power mode is switched to "OFF" (models with passive entry and start system) or the starter switch is turned to the "LOCK" position (models without passive entry and start system) and the driver's door is opened. A warning buzzer sounds at the same time. When the light control switch is placed in the "OFF" position, the warning light will go out and the warning buzzer will stop sounding.

Warning Buzzer → Refer to page 4-111

Key Remain Warning Light



Models with MID

In models without a passive entry and start system, this message appears on the display when the starter switch is placed in the "ACC" or "LOCK" position and the driver's door is opened when the key has not been removed. A warning buzzer will sound at the same time. When the key is removed, the warning light will go out and the warning buzzer will stop sounding.

Warning Buzzer → Refer to page 4-111

Passive Entry and Start System Warning Light

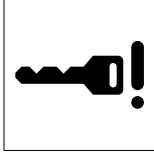

Models with Passive Entry and Start System

This warning light comes on when there are abnormalities in the passive entry and start system, power management system, or steering wheel lock system.



ADVICE

- If the warning light comes on repeatedly or remains on, have the vehicle inspected/serviced at the nearest Isuzu Dealer as soon as possible.

Passive Entry and Start System

→ Refer to page 3-11

No Electronic Key Warning Light



Models with Passive Entry and Start System

This message appears on the display in the following cases:

- If locking of an unlocked door is attempted with the electronic key not within operating range for locking and unlocking the doors.
- If the electronic key is carried outside the vehicle and then the doors are closed with the power mode in "ACC" or "ON".
- If the power mode is "OFF" and the engine start/stop button is pushed with the electronic key not within operating range for starting the engine.

At this time, the warning buzzer will sound.

**NOTE**

- Even when the electronic key is within the operating range for locking and unlocking the doors, this warning light may be displayed due to radio wave conditions. Also, even when the electronic key is within the operating range for starting the engine, this warning light may be displayed if the key is located above the instrument panel, in storage areas such as the glove box or door pocket, as well as under the seat or on the floor in front of the driver and passenger seats.
- If the vehicle battery is weak or the voltage is low, this warning light may be displayed when the lock buttons on the driver side door handle are pressed, or when the starter switch is pushed. In this case, check the vehicle's battery.
- If the electronic key is passed through an open window and carried outside of the vehicle, this warning light will not be displayed.

Passive Entry and Start System

→ Refer to page 3-11

Warning Buzzer → Refer to page 4-111**Handling the Battery**

→ Refer to page 6-101

Steering Wheel Lock Not Released Warning Light



Models with Passive Entry and Start System

This message appears on the display if the steering wheel lock is not released even though the engine start/stop button is pushed.

At this time, the warning buzzer will sound and the engine start/stop button indicator light will flash in green.

Passive Entry and Start System

→ Refer to page 3-11

Warning Buzzer → Refer to page 4-111

Engine Start/Stop Button (Models with Passive Entry and Start System)

→ Refer to page 4-116

Door Open Warning Light

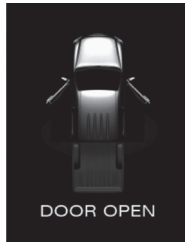

Models with Passive Entry and Start System

This message appears on the display if door locking is attempted by pressing the lock button on the driver side door handle or electronic key when the doors are open. At this time, the warning buzzer will sound. If this warning light is displayed, the doors will not lock even if the lock buttons on the driver side door handle or electronic key are pressed.

Passive Entry and Start System

→ Refer to page 3-11

Warning Buzzer → Refer to page 4-111

Shift Position Warning Light

Manual transmission model



Automatic transmission model



TO POWER OFF
SHIFT TO P
THEN PUSH
START BUTTON

Models with Passive Entry and Start System

This message appears on the display in the following cases:

- If the electronic key is carried outside the vehicle and then the doors are closed with the power mode in "OFF" and the selector lever in a position other than "P" (automatic transmission model).
- If the selector lever is moved to a position other than "P" with the driver side door open (automatic transmission model).
- If starting of the engine is attempted by pushing the engine start/stop button with the selector lever in a position other than "P" or "N" (automatic transmission model).
- If starting of the engine is attempted by pushing the engine start/stop button with the gearshift lever in a position other than "N" (manual transmission model).
- If an attempt to switch the power mode from "ON" to "OFF" is made with the selector lever in a position other than "P" (automatic transmission model).

At this time, the warning buzzer will sound.

Passive Entry and Start System

→ Refer to page 3-11

Warning Buzzer → Refer to page 4-111

Turn Off the Power Warning Light



Models with Passive Entry and Start System

This message appears on the display if door locking is attempted by pressing the lock button on the driver side door handle or electronic key with the power mode in "ON" or "ACC". In this case, the doors will not lock.

At this time, the warning buzzer will sound.

Passive Entry and Start System

→ Refer to page 3-11

Warning Buzzer → Refer to page 4-111

Engine Start/Stop Button (Models with Passive Entry and Start System)

→ Refer to page 4-116

Low Battery Electronic Key Warning Light

**Models with Passive Entry and Start System**

This message appears on the display if the battery voltage of the electronic key is low when the power mode is switched from "ON" to "OFF" (or "ACC").

At this time, the warning buzzer will sound.

**NOTE**

- If this warning light is displayed, the passive entry and start system may not function. Replace the electronic key battery as soon as possible. If the passive entry and start system does not function, use the mechanical key for locking and unlocking the doors and use the electronic key for starting the engine (refer to "When the Electronic Key Battery Goes Flat").

Passive Entry and Start System

→ Refer to page 3-11

Replacing the Battery in the Remote

Control Unit → Refer to page 3-17

Warning Buzzer → Refer to page 4-111

When the Electronic Key Battery Goes

Flat → Refer to page 7-7

Check System Warning Light



Models with Passive Entry and Start System

This message appears on the display if an error occurs to the passive entry and start system when door locking is attempted by pressing the lock button on the driver side door handle or by pushing the engine start/stop button. At this time, the following may occur:

- The warning buzzer will sound.
- The passive entry and start system warning light may come on.
- The engine start/stop button indicator light may flash.



ADVICE

- If the warning light comes on repeatedly or remains on, have the vehicle inspected/serviced at the nearest Isuzu Dealer as soon as possible.



NOTE

- If this warning light is displayed, the passive entry and start system function cannot be used.
- This warning light may also be displayed if the fuse is blown.

Passive Entry and Start System

→ Refer to page 3-11

Passive Entry and Start System Warning Light

→ Refer to page 4-91

Engine Start/Stop Button (Models with Passive Entry and Start System)

→ Refer to page 4-116

Warning Buzzer

→ Refer to page 4-111

Emergency Engine Starting (Models with Passive Entry and Start System)

→ Refer to page 7-11

Replacing the Fuses and Relays

→ Refer to page 7-46

Power Management System Warning Light**Models with Passive Entry and Start System**

This message appears on the display if an error occurs to the power management system when the engine start/stop button is pushed. At this time, the warning buzzer will sound and the passive entry and start system warning light will come on.

**ADVICE**

- If the warning light comes on repeatedly or remains on, have the vehicle inspected/serviced at the nearest Isuzu Dealer as soon as possible.

Passive Entry and Start System

→ Refer to page 3-11

Passive Entry and Start System Warning Light

→ Refer to page 4-91

Warning Buzzer

→ Refer to page 4-111

Steering Wheel Lock System Warning Light**Models with Passive Entry and Start System**

This message appears on the display if an error occurs to the steering wheel lock system when the engine start/stop button is pushed. At this time, the warning buzzer will sound and the passive entry and start system warning light will come on.

**ADVICE**

- If the warning light comes on repeatedly or remains on, have the vehicle inspected/serviced at the nearest Isuzu Dealer as soon as possible.

Passive Entry and Start System

→ Refer to page 3-11

Passive Entry and Start System Warning Light

→ Refer to page 4-91

Warning Buzzer → Refer to page 4-111

Accessory Mode Indicator Light**Manual transmission model****Automatic transmission model****Models with Passive Entry and Start System**

This message appears on the display when the power mode is in "ACC". If the driver side door is opened with the power mode in "ACC", the warning buzzer will sound.

Passive Entry and Start System

→ Refer to page 3-11

Warning Buzzer → Refer to page 4-111

Low Battery Engine Starting Indicator Light



Models with Passive Entry and Start System

This message appears on the display when the electronic key battery goes flat.

Passive Entry and Start System

→ Refer to page 3-11

When the Electronic Key Battery Goes Flat

Flat

→ Refer to page 7-7

Manual transmission model



Automatic transmission model

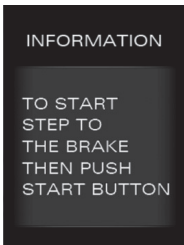

Turn Signal Indicator Light

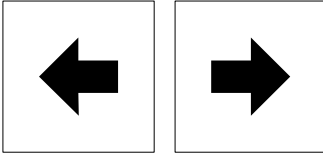

Either of these indicator lights flashes when the turn signal switch is operated with the power mode in "ON" (models with passive entry and start system) or the starter switch in the "ON" position (models without passive entry and start system).

Both indicator lights flash when the hazard warning flasher switch is operated irrespective of the power mode (models with passive entry and start system) or the position of the starter switch (models without passive entry and start system).

Turn Signal Switch

→ Refer to page 4-123



ADVICE

- These indicator lights will not flash if the bulbs are blown, or may flash abnormally if bulbs of incorrect wattage are used.

Light Position Indicator Light

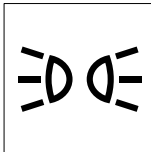

This indicator light should come on when the power mode is switched to "ON" (models with passive entry and start system) or the starter switch is turned to the "ON" position (models without passive entry and start system), and then should go out after approximately 3 seconds.

This indicator light comes on when the light switch is in the "ON" position.

High Beam Indicator Light

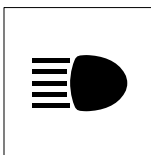

This indicator light comes on when high beam is selected or the headlights are cycled between high and low beams (passing signal).

Light Control Switch

→ Refer to page 4-121

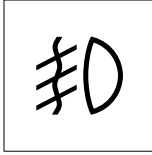
Front Fog Light Indicator Light

This indicator light stays on while the front fog lights are on.

Front Fog Light Switch

→ Refer to page 4-125

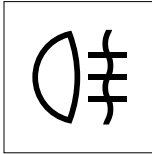
Rear Fog Light Indicator Light

This indicator light stays on while the rear fog light is on.

Rear Fog Light Switch

→ Refer to page 4-125

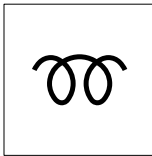
Glow Plug Indicator Light

This indicator comes on in the following cases and goes out when the preheating of the glow plug is completed:

- If the power mode is switched to "ON" (models with passive entry and start system).
- If starting of the engine is attempted (models with passive entry and start system).
- If the starter switch is turned to the "ON" position (models without passive entry and start system).

Starting the Engine

→ Refer to page 4-4

TCS OFF Indicator Light

A rectangular box containing the text "TCS OFF" in a bold, sans-serif font.

When the power mode is switched to "ON" (models with passive entry and start system) or the starter switch is turned to the "ON" position (models without passive entry and start system), the TCS OFF indicator light turns on before going out after approximately 3 seconds. The TCS OFF function is normal if the indicator light goes out. When you wish to cancel the TCS OFF after the engine is started, press the ESC OFF switch for approximately 1 second, and the TCS OFF indicator light in the instrument panel will turn on.

When the TCS OFF indicator light does any of the following, the TCS OFF function may be faulty. Please contact the nearest Isuzu Dealer.

- When the TCS OFF indicator light comes on during driving (when the ESC OFF switch is not operated).
- The TCS OFF indicator light does not turn on when the power mode is switched to "ON" (models with passive entry and start system) or the starter switch is turned to the "ON" position (models without passive entry and start system).

**NOTE**

- In models with 4WD, the ESC OFF indicator light will turn on, and the ESC and TCS engine power control function will not activate when the 4WD switch is set to 4L (4WD low). If you wish to turn the TCS brake control function off as well, press this ESC OFF switch for approximately 5 seconds to cancel the TCS brake control function and cause the TCS OFF indicator light in the instrument panel to turn on.

Electronic Stability Control (ESC)

→ Refer to page 4-163

Four Wheel Drive (4WD) Model

→ Refer to page 4-176

ESC OFF Indicator Light



When the power mode is switched to "ON" (models with passive entry and start system) or the starter switch is turned to the "ON" position (models without passive entry and start system), the ESC OFF indicator light turns on before going out after approximately 3 seconds. The ESC OFF function is normal if the indicator light goes out.

When you wish to cancel the ESC after the engine is started, press the ESC OFF switch for approximately 5 seconds to cancel the ESC and cause the ESC OFF indicator light in the instrument panel to turn on.

When the ESC OFF indicator light does any of the following, the ESC function may be faulty. Please contact the nearest Isuzu Dealer.

- When the ESC OFF indicator light comes on during driving (when the ESC OFF switch is not operated).
- The ESC OFF indicator light does not turn on when the power mode is switched to "ON" (models with passive entry and start system) or the starter switch is turned to the "ON" position (models without passive entry and start system).

**NOTE**

- In models with 4WD, the ESC OFF indicator light will turn on, and the ESC and TCS engine power control function will not activate when the 4WD switch is set to 4L (4WD low).

Electronic Stability Control (ESC)

→ Refer to page 4-163

Four Wheel Drive (4WD) Model

→ Refer to page 4-176

Cruise Control Main Indicator Light

Cruise control main indicator light



CRUISE MAIN POWER (models with MID)

CRUISE
MAIN POWER

This indicator light should come on when the power mode is switched to "ON" (models with passive entry and start system) or the starter switch is turned to the "ON" position (models without passive entry and start system), and then should go out after approximately 3 seconds.

In models with an MID, when the cruise control main switch is pressed, this indicator light comes on after the "CRUISE MAIN POWER" is displayed on the MID for approximately 3 seconds and then goes out.

In models with an LCD, when the cruise control main switch is pressed, this indicator light comes on.

Cruise control main switch

→ Refer to page 4-154

Cruise Control Set Indicator Light

Cruise control set indicator light



CRUISE SET (models with MID)

CRUISE SET

This indicator light should come on when the power mode is switched to "ON" (models with passive entry and start system) or the starter switch is turned to the "ON" position (models without passive entry and start system), and then should go out after approximately 3 seconds.

In models with an MID, when the vehicle enters the cruise control mode after the cruise control set switch is operated to set the vehicle speed, this indicator light comes on after the "CRUISE SET" is displayed on the MID for approximately 3 seconds and then goes out.

In models with an LCD, when the vehicle enters the cruise control mode after the cruise control set switch is operated to set the vehicle speed, this indicator light comes on.

Cruise control set switch

→ Refer to page 4-154

4WD Indicator Light

4WD indicator light



4H (models with MID)

4H

This indicator light should come on when the power mode is switched to "ON" (models with passive entry and start system) or the starter switch is turned to the "ON" position (models without passive entry and start system), and then should go out after approximately 3 seconds.

In models with an MID, when the 4WD switch is used to select "4H (4WD high)" or "4L (4WD low)", this indicator light comes on. At the same time, the "4H" is displayed on the MID for approximately 3 seconds and then goes out.

In models with an LCD, when the 4WD switch is used to select "4H (4WD high)" or "4L (4WD low)", this indicator light comes on.

Whenever you use the 4WD switch, check that the 4WD indicator light has come on or gone out as expected before driving.

4WD Switch → Refer to page 4-177

4WD Low Indicator Light

4WD low indicator light



4L (models with MID)



This indicator light should come on when the power mode is switched to "ON" (models with passive entry and start system) or the starter switch is turned to the "ON" position (models without passive entry and start system), and then should go out after approximately 3 seconds.

In models with an MID, when the 4WD switch is used to select "4L (4WD low)", this indicator light comes on. At the same time, the "4L" is displayed on the MID for approximately 3 seconds and then goes out.

In models with an LCD, when the 4WD switch is used to select "4L (4WD low)", this indicator light comes on.

Whenever you use the 4WD switch, check that the 4WD low indicator light has come on or gone out as expected before driving.

4WD Switch → Refer to page 4-177

2WD Indicator Light



Models with MID

When the 4WD switch is used to select "2H (2WD)", the "2H" is displayed on the MID for approximately 3 seconds and then goes out.

4WD Switch → Refer to page 4-177

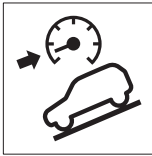
Hill Descent Control Indicator Light**Hill descent control indicator light
(models with MID)****Hill descent control indicator light
(models with LCD)****HILL DESCENT CONTROL
(models with MID)****HILL DESCENT
CONTROL**

This indicator light should come on when the power mode is switched to "ON" (models with passive entry and start system) or the starter switch is turned to the "ON" position (models without passive entry and start system), and then should go out after approximately 3 seconds.

In models with an MID, when the hill descent control switch is pressed and the hill descent control is activated, this indicator light will turn on after "HILL DESCENT CONTROL" is displayed on the MID for approximately 3 seconds and then goes out.

In models with an LCD, when the hill descent control switch is pressed and the hill descent control is activated, this indicator light will come on.

Hill Descent Control

→ Refer to page 4-172

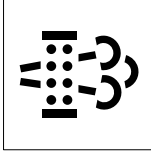
DPD Operator Regeneration Indicator Light**DPD operator regeneration indicator light****CHECKING PM LEVEL
(models with MID)**

This indicator light should come on when the power mode is switched to "ON" (models with passive entry and start system) or the starter switch is turned to the "ON" position (models without passive entry and start system), and then should go out after the engine is started.

In models with an MID, when operator regeneration of DPD is required, this indicator light flashes after the "CHECKING PM LEVEL" is displayed on the MID for approximately 3 seconds and then goes out.

In models with an LCD, when operator regeneration of DPD is required, this indicator light flashes.

In this case, perform operator regeneration as soon as possible according to the "Operator Regeneration Procedure".

When operator regeneration begins, the indicator light will switch from intermittent flashing to continuous illumination, and will go off once regeneration is complete.

Diesel Particulate Defuser (DPD)

→ Refer to page 4-184

Operator Regeneration of DPD

→ Refer to page 4-185

Operator Regeneration Procedure

→ Refer to page 4-186

Warning Buzzer

A warning buzzer sounds under the following conditions.

Warning	Buzzer pattern	Condition
Engine overheat	Continuous beep	When the engine overheats.
Key remain (models without passive entry and start system)	Short repeated beeps	When the driver's door is opened if the key has not been removed and the starter switch is in the "ACC" or "LOCK" position.
Light control OFF	Short repeated beeps (models with MID)	When the light control switch is set to "OFF" or "LOCK", the power mode is switched to "OFF" (models with passive entry and start system) or the starter switch is turned to the "LOCK" position (models without passive entry and start system) and the driver's door is opened.
	Continuous beeps (models with LCD)	
Parking brake release	Short repeated beeps	When the vehicle speed exceeds approximately 5 km/h (3.1 MPH) during driving with the parking brake engaged.
Seat belt (Driver seat)*	Short repeated beeps	When the vehicle speed exceeds approximately 20 km/h (12 MPH) during driving with the seat belt unfastened.
Seat belt (Front passenger seat)*	Short repeated beeps	When the vehicle speed exceeds approximately 20 km/h (12 MPH) during driving with the seat belt unfastened.
Reverse shift (models with manual transmission)	Three repeated beeps	When the gearshift lever is placed in the "R (reverse)" position.
Automatic transmission	Three repeated beeps	When the transmission is shifted to a low gear while the vehicle speed is too fast. When the transmission is shifted to a high gear while the vehicle speed is too slow.
4WD	Short repeated beeps	When the vehicle speed, engine speed, gearshift lever (manual transmission models) or the selector lever (automatic transmission models) position, or clutch pedal operating condition (manual transmission models) conflict with the changing conditions or when changing is not possible due to a 4WD system abnormality.

*: Models with side airbag and curtain airbag.

4-112

CONTROLS AND INSTRUMENTS

Warning	Buzzer pattern	Condition
No electronic key (models with passive entry and start system)	Short repeated beeps (external buzzer)	If locking of an unlocked door is attempted with the electronic key not within operating range for locking and unlocking the doors.
	Short repeated beeps (in-vehicle buzzer)	If the electronic key is carried outside the vehicle and then the doors are closed with the power mode in "ACC" or "ON".
	Short repeated beeps (external buzzer)	If the power mode is "OFF" and the engine start/stop button is pushed with the electronic key not within operating range for starting the engine.
	Three repeated beeps (in-vehicle buzzer)	If the power mode is "OFF" and the engine start/stop button is pushed with the electronic key not within operating range for starting the engine.
Steering wheel lock not released (models with passive entry and start system)	Three repeated beeps (in-vehicle buzzer)	If the steering wheel lock is not released even though the engine start/stop button is pushed.
Door open (models with passive entry and start system)	Short repeated beeps (external buzzer)	If door locking is attempted by pressing the lock button on the driver side door handle or electronic key when the doors are open.
Shift position (models with passive entry and start system)	Continuous beep (external buzzer)	If the electronic key is carried outside the vehicle and then the doors are closed with the power mode in the "OFF" and the selector lever in a position other than "P" (automatic transmission model).
	Short repeated beeps (in-vehicle buzzer)	If the selector lever is moved to a position other than "P" with the driver side door open (automatic transmission model).
	Three repeated beeps (in-vehicle buzzer)	If starting of the engine is attempted by pushing the engine start/stop button with the selector lever in a position other than "P" or "N" (automatic transmission model).
	Three repeated beeps (in-vehicle buzzer)	If starting of the engine is attempted by pushing the engine start/stop button with the gearshift lever in a position other than "N" (manual transmission model).
	Three repeated beeps (in-vehicle buzzer)	If an attempt to switch the power mode from "ON" to "OFF" is made with the selector lever in a position other than "P" (automatic transmission model).

Warning	Buzzer pattern	Condition
Turn off the power (models with passive entry and start system)	Short beep (external buzzer)	If door locking is attempted by pressing the lock button on the driver side door handle or electronic key with the power mode in "ON" or "ACC".
Low battery electronic key (models with passive entry and start system)	Three repeated beeps (in-vehicle buzzer)	If the battery voltage of the electronic key is low when the power mode is switched from "ON" to "OFF" (or "ACC").
Check system (models with passive entry and start system)	Three repeated beeps (in-vehicle buzzer) Continuous beep (in-vehicle buzzer)	If an error occurs to the passive entry and start system when door locking is attempted by pressing the lock button on the driver side door handle or by pushing the engine start/stop button.
	Short beep (external buzzer) Continuous beep (external buzzer)	
Power management system (models with passive entry and start system)	Three repeated beeps (in-vehicle buzzer)	If an error occurs to the power management system when the engine start/stop button is pushed.
Steering wheel lock system (models with passive entry and start system)	Three repeated beeps (in-vehicle buzzer)	If an error occurs to the steering wheel lock system when the engine start/stop button is pushed.
Accessory mode (models with passive entry and start system)	Short repeated beeps (in-vehicle buzzer)	If the driver side door is opened with the power mode in "ACC".
Lockout prevention (models with passive entry and start system)	Short repeated beeps (external buzzer)	If door locking is attempted by pressing the lock button on the driver side door handle when the electronic key is within operating range for starting the engine.



ADVICE

- The warning buzzer may not sound if there is a problem with the system. If this occurs, the system needs to be inspected. Please contact the nearest Isuzu Dealer.

4-114

CONTROLS AND INSTRUMENTS



SWITCHES

• Engine Start/Stop Button (Models with Passive Entry and Start System)	4-116
• Starter Switch (Models without Passive Entry and Start System)	4-119
• Combination Light Control Switch	4-121
• Headlight Leveling Switch	4-124
• Front Fog Light Switch	4-125
• Rear Fog Light Switch	4-125
• Hazard Warning Flasher Switch	4-126
• Windshield Wiper and Windshield Washer Switch	4-127
• Horn Button	4-129
• Remote Control Mirror Switch	4-129
• Retractable Power Mirror Switch	4-130
• Illumination Control Switch	4-131
• Heated Seat Switch	4-132
• Rear Window Defogger Switch	4-133

Engine Start/Stop Button (Models with Passive Entry and Start System)

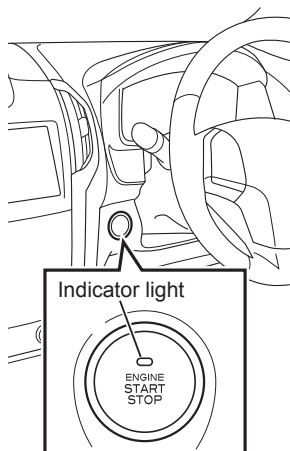

This button is used to start/stop the engine and switch the power mode.

To change the power mode, push the engine start/stop button when the brake pedal (models with automatic transmission) or clutch pedal (models with manual transmission) is not depressed and while the electronic key is on your person. The power mode will switch from "OFF" to "ACC" to "ON" in that order each time the button is pushed.

OFF : In this mode, the steering wheel will be locked to help prevent theft.

ACC : In this mode, the audio and other accessories can be used with the engine stopped.

ON : The power mode stays in this mode while the engine is running.



NOTE

- When performing the update operation in the "Changing the Oil and Oil Filter (RZ4E Engine Model)" procedure, make sure that the engine is stopped when switching the power mode to "ON".

Changing the Oil and Oil Filter (RZ4E Engine Model) → Refer to page 6-30

→ : Push the engine start/stop button

➡ : Push the engine start/stop button (selector lever is in "P")

••▶ : Push the engine start/stop button (selector lever is other than "P")

Power mode	Manual transmission models (clutch pedal is not depressed)	Automatic transmission models (brake pedal is not depressed)
OFF		
ACC		
ON		



ADVICE

- Do not touch the engine start/stop button with hands dirtied with oil, etc.
- Take care not to spill drinks, etc., on the button. If such spillages should occur, immediately contact your nearest Isuzu Dealer.
- When the engine start/stop button is stuck, do not attempt to operate the button, but instead immediately contact your nearest Isuzu Dealer.



NOTE

- By using the passive entry and start system to verify the electronic key, the engine can be started and the power mode can be switched.
- The power mode may not change if the engine start/stop button is pressed rapidly. Push the button carefully until the desired power mode is reached.
- The engine start/stop button indicator light will turn on in amber if the power mode is in "ACC" or "ON".
- When the power mode is "ACC", "ACCESSORY MODE" will be displayed in the MID.

NOTE (Continued)

NOTE (Continued)

- The battery power saving function will operate and the power mode will switch to "OFF" when 60 minutes have passed with the power mode in "ACC". When this happens, the doors will unlock. The settings for the battery power saving function and the unlock function can be changed. To change the settings, please contact your Isuzu Dealer.
- When the power mode is "ON", the instrument panel will be illuminated.
- If the power mode is switched from "ON" to "OFF" and the driver side door is opened or closed while the vehicle is stopped, the steering wheel lock will activate.
- If the engine start/stop button is pushed while the vehicle is stopped and the power mode is "OFF", the steering wheel lock will be deactivated.
- If the engine start/stop button illumination does not come on even though the light control switch is operates, contact your nearest Isuzu Dealer.
- When the engine start/stop button indicator light flashes in green after an attempt to start the engine has been made, the engine will not be able to be started due to the steering wheel lock not be unlocked. Try starting the engine again while turning the steering wheel to the right and left.

Starter Switch (Models without Passive Entry and Start System)

WARNING

- While driving, never turn the starter switch to the "LOCK" position. The key could be removed from the switch, which then locks the steering wheel. This is extremely dangerous.

ADVICE

- Using a key sticking with dirt or dust, etc. may possibly damage the starter switch. Make sure to wipe off any dirt or dust, etc. before inserting the key.
- After starting the engine, do not turn the starter switch to the "START" position. Otherwise, the starter motor may be damaged.
- Using electrical devices such as the audio system for an extended time period with the engine stopped can completely discharge the battery.

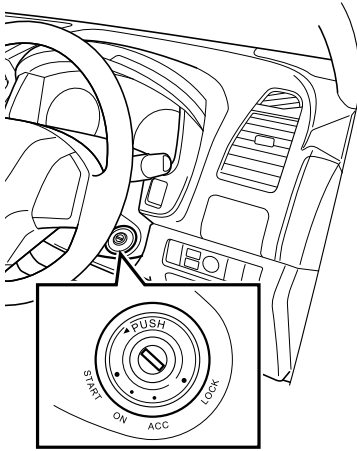

- LOCK** : In this position, the key can be inserted or removed.
Remove the key and turn the steering wheel until it locks. The steering wheel will be locked to help prevent theft. To place the starter switch in the "LOCK" position, press and hold the key in the "ACC" position and then turn it to the "LOCK" position.
- ACC** : In this position, the audio and other accessories can be used with the engine stopped.
- ON** : The key stays in this position while the engine is running. This position is also used for preheating before starting the engine.
- START** : The engine is started in this position. Release the key as soon as the engine has started. The key automatically returns to the "ON" position.

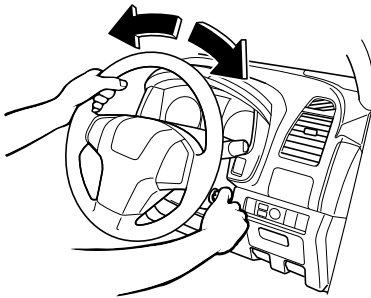
**NOTE**

- If the key cannot be turned from the "LOCK" position to the "ON" position, lightly move the steering wheel clockwise and counterclockwise while trying to turn the key.

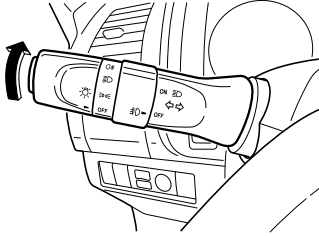
Combination Light Control Switch**Light Control Switch**



Turning the light control switch to the position indicated in the table causes the relevant lights to illuminate.

**ADVICE**

- Each light will come on regardless of the power mode (models with passive entry and start system) or position of the starter switch (models without passive entry and start system). Do not operate the combination lights for an extended time period with the engine stopped. Otherwise, the battery may go flat, making it impossible to restart the engine.



**NOTE**

- When repeatedly turning the headlight bulbs on and off frequently, the service life of the headlight bulbs will be reduced.
- The clearance light also functions as the daytime running light. The way they function depends on the driving situation.

Name	Position			
	OFF			
Headlight	Off	Off	On	On
Taillight		On		
License plate light			On	
Illumination light control		Off	Off	
Rear fog light (if equipped)		Off	Off	
Clearance light/daytime running light	On*1	On*2		

*1: The lights function as daytime running lights when the following conditions are met.

1) The engine has been started. 2) The light control switch is in the "OFF" position.

*2: When the light control switch is in the "" or "" position, the lights will become dimmer than when the switch is in the "OFF" position and function as clearance lights.

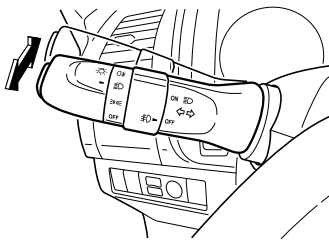

Switching between High Beam and Low Beam

With the headlights on, move the lever forward and backward to switch between the high beam and low beam.

Moving the lever forward selects high beam; moving the lever backward selects low beam.

While the headlights are on high beam, the high beam indicator light on the instrument panel remains on.

When the Bulb Does not Come On

→ Refer to page 7-34

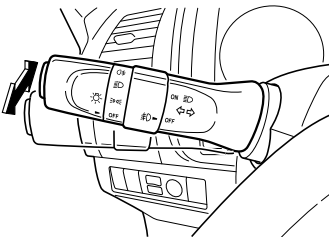

Switching between High and Low Beams (Flash-to-Pass Signal)

By lightly pulling the light control switch lever and releasing it, the high beam comes on and off. At the same time, the high beam indicator light on the instrument panel comes on and off. Use this function as a signal for flash-to-pass a vehicle or other purposes.

Turn Signal Switch

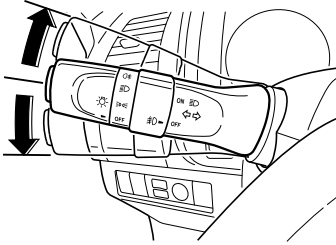

When turning left or right, move the lever up or down to flash the turn signal light.



ADVICE

- The turn signal lights come on when the power mode is "ON" (models with passive entry and start system) or the starter switch is in the "ON" position (models without passive entry and start system). Do not operate the turn signal lights for an extended time period with the engine stopped. Otherwise, the battery may go flat, making it impossible to start the engine.



NOTE

- If the steering wheel is only turned a small amount, turn off the signal manually. Lightly press and hold the lever up or down when overtaking or changing lanes.

Headlight Leveling Switch

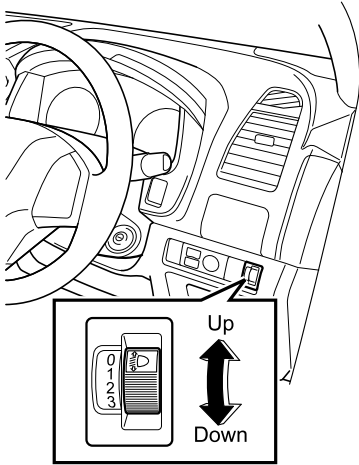

The headlight aim can be adjusted at four different angles. When the cargo load causes the headlights to aim upwards, this feature can be used to lower the aiming angle.

When your vehicle is not loaded with cargo, the switch should be set at the uppermost position. ("0" position)

Make adjustments in accordance with the following table.



CAUTION

- Do not lower the aiming angle too much. Otherwise, the illuminated range may be so reduced that you may be involved in an accident.

Position	Load
0	No Load.
1	When loaded to about 300 kg (660 lb).
2	When loaded to about 650 kg (1,430 lb).
3	When loaded up to the maximum.

Front Fog Light Switch

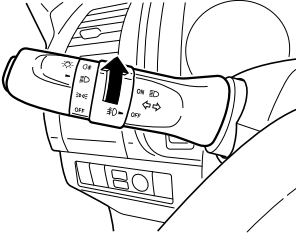

Front fog light indicator light

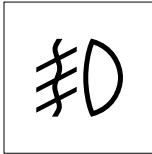

When the light control switch is placed in the "OFF" or "ON" position, turn this switch to the "ON" position to come on the front fog lights, and then the front fog light indicator light will come on. To turn off the lights, place the switch in the "OFF" position. The front fog lights are useful when forward visibility is poor such as in fog.

WARNING

- When replacing a front fog light bulb, do not use one of a larger wattage than the specified wattage. Otherwise, the wiring may be burned.

When the Bulb Does not Come On
→ Refer to page 7-34

Rear Fog Light Switch

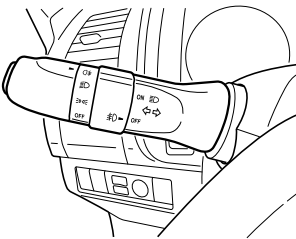

Rear fog light indicator light

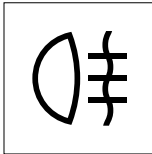

When the light control switch is placed in "ON", the rear fog light comes on and the rear fog light indicator light comes on. Use this feature in low visibility such as in fog.

WARNING

- When replacing a rear fog light bulb, do not use one of a wattage larger than the specified wattage. Otherwise, the wiring may be burned.

When the Bulb Does not Come On
→ Refer to page 7-34

Hazard Warning Flasher Switch

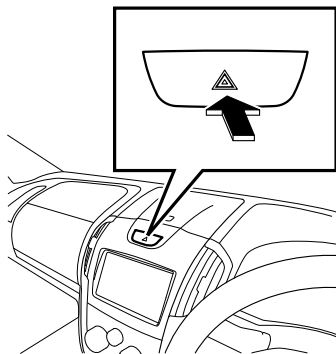

The hazard warning flasher is used to signal other vehicles that your vehicle is stationary on the road because of an accident or component failure.

With the power mode in any mode (models with passive entry and start system) or the starter switch in any position (models without passive entry and start system), when this switch is pressed, all of the turn signal lights and the turn signal indicator lights flash to signal an emergency. To turn off the hazard lights, press the switch again.



ADVICE

- Do not leave the hazard warning flasher operating for an extended time period with the engine stopped. Otherwise, the battery may go flat, making it impossible to restart the engine.

Windshield Wiper and Windshield Washer Switch

To use the windshield wiper and washer switches, the power mode must be "ON" (models with passive entry and start system) or the starter switch must be in the "ON" position (models without passive entry and start system).

Windshield Wiper Switch



ADVICE

- Clear ice or packed snow from the wiper blades before using the wipers.
- Before operating the wiper, ensure that the wiper rubber is not stuck on to the windshield. If the wiper rubber is stuck to the windshield and you still operate the wiper, the wiper may break or the wiper motor may fail.
- Do not operate the wiper on a dry windshield surface. Otherwise, the windshield surface may sustain damage. Always use the windshield washer when wiping a dry glass surface.
- The safety system may work to stop the wiper when excessive load is applied on the motor. In this case, turn the switch to the "OFF" position and, a few minutes later, check to see if the wiper is back to normal operation. If the wiper frequently stops operation, refrain from using it and contact the nearest Isuzu Dealer.

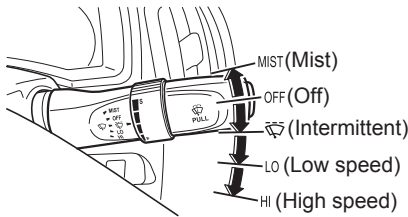

The windshield wiper switch has the following positions, which correspond to the states of the wiper.

Lever position	Wiper state
MIST	Operates when the lever is held upward
OFF	Stopped
	Intermittent (Light rain)
LO	Low speed (Moderate rain)
HI	High speed (Heavy rain)

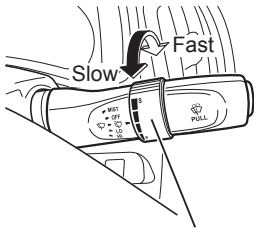

Intermittent ring

Variable Intermittent Windshield Wiper

The wipers will operate intermittently when the intermittent ring is rotated to the "☒" position. The interval between wiper sweeps can be adjusted within a range of approximately 1.5 to 15 seconds by turning the intermittent ring.

Windshield Washer Switch

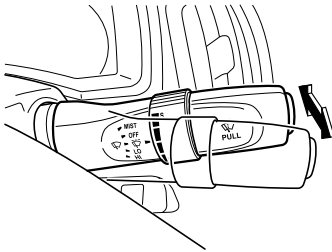

Windshield washer fluid is sprayed over the windshield when this switch is pressed. At the same time, the windshield wiper operates.

The windshield washer is used when the windshield is being wiped during clean.



CAUTION

- At extremely low temperatures, washer fluid may freeze on the windshield after being sprayed, obstructing your forward view. In such a case, warm up the windshield before using the windshield washer.



ADVICE

- If windshield washer fluid does not come out in sufficient quantity, immediately release the switch. Otherwise, the windshield surface may sustain damage.
- Do not hold the switch pressed for more than 30 seconds. Otherwise, the washer pump may sustain damage.
- If windshield washer fluid does not come out, release the windshield washer switch immediately. Otherwise the motor may seize up.
- When the vehicle is used in a cold-climate region, use washer fluid with appropriate concentration for the season to prevent frozen fluid.

Windshield Washer Fluid

→ Refer to page 6-96

Horn Button

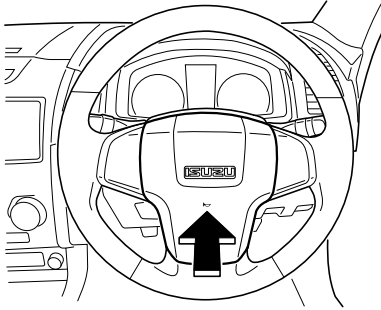

To sound the horn, press the pad with a horn symbol on the steering wheel.

Remote Control Mirror Switch

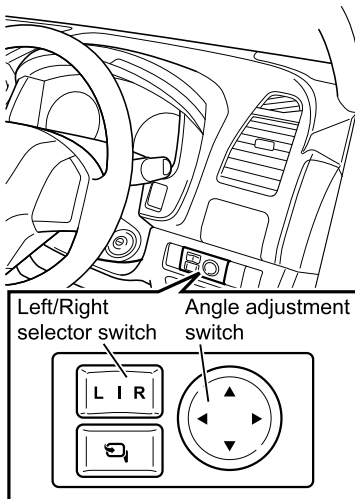

The remote control mirror switch is active only when the power mode is "ACC" or "ON" (models with passive entry and start system) or the starter switch is in the "ACC" or "ON" position (models without passive entry and start system).

Adjust

1. Press the left/right selector switch on the "L" or "R" side to adjust the mirror in the desired direction.
2. Press the angle adjustment switch to adjust the mirror angle. After adjusting, return the left/right selector switch to the middle position.

WARNING

- Adjust the mirrors when the vehicle is stationary, not while the vehicle is in motion.



ADVICE

- Do not try to forcefully move the mirror surface by hand. Otherwise, the mirror motor may sustain damage.

Retractable Power Mirror Switch

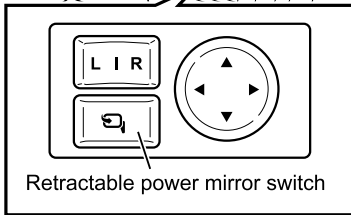
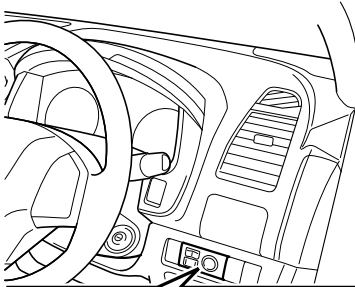

Retractable power mirror switch

The retractable power mirror switch is active only when the power mode is "ACC" or "ON" (models with passive entry and start system) or the starter switch is in the "ACC" or "ON" position (models without passive entry and start system).

Press the switch to retract the right and left mirrors. To extend the mirrors, press the switch again.

WARNING

- Adjust the mirrors when the vehicle is stationary, not while the vehicle is in motion.
- Do not operate the retractable power mirrors while driving as this is dangerous and could cause an accident.
- Do not drive with the mirrors folded in. Before driving, be sure to adjust both the driver's side mirror and passenger's side mirror to their original positions.

CAUTION

- Do not touch the mirrors with a hand while the mirrors are moving. It could cause your hands to be pinched or a mirror malfunction.

ADVICE

- When moving the mirror manually, do not use more force than necessary.
- Although the retractable power mirror can be moved manually as well, we recommend that you electrically move the mirror to prevent malfunction.

Illumination Control Switch

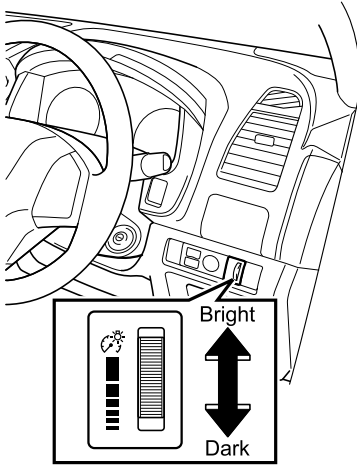

This switch is used to adjust the brightness of the illumination in the instrument panel. Turning the switch up brightens the lights, and turning the switch down darkens them. The brightness can be adjusted with the light control switch in the "☀️" or "☾️" position.



NOTE

- In models with an MID, meter brightness is not adjusted in coordination with illumination control switch operation.
- In models with an LCD, the brightness of meter dials and needles is adjusted in coordination with illumination control switch operation. (However, the illumination brightness of the LCD is automatically adjusted according to the brightness inside the vehicle and is not adjusted in coordination with illumination control switch operation.)

Heated Seat Switch

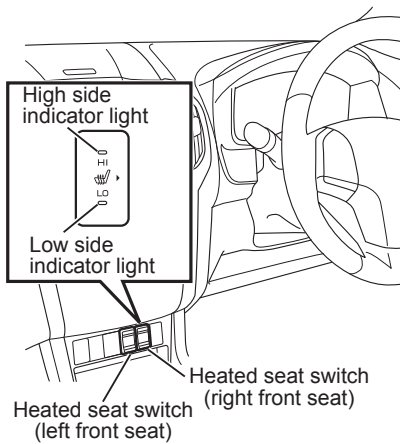

The heated seat can be used when the power mode is "ON" (models with passive entry and start system) or the starter switch is in the "ON" position (models without passive entry and start system). Press the "HI" side of the switch to warm the seat quickly. The high side indicator light of the switch comes on. After the seat has been warmed, press the "LO" side to keep the seat warm. The low side indicator light of the switch comes on. When the switch is placed in the neutral position, the function is set to off.

CAUTION

- The following persons should be careful so as not to receive a low temperature burn.
 - Babies and infants, elderly persons, sick persons and physically-disabled persons
 - Children
 - Persons who take drowsy medicines
 - Persons with delicate skin
 - Persons who are extremely exhausted
 - Persons who have drunk alcohol
- To prevent overheating, do not use the seat with blankets and cushion that keep it too warm.
- To prevent low temperature burn, do not use the heated seat function when napping in the vehicle.

**ADVICE**

- Do not use the heated seat when the engine is not running. The heated seat consumes a lot of electricity and could discharge the battery completely.
- Do not place or set on the seats items such as a solid and heavy material, or nails and screws that have a sharp protruded edge. This could cause the heater wiring to break to be disconnected.
- If you spill water or a beverage on the seat, wipe it off with a dry cloth immediately.
- Do not use organic solvents such as mineral oil, benzine, thinner, or gasoline to clean the seats. Doing so may result in damage to the heater or seat covering.

Rear Window Defogger Switch**Automatic Air Conditioner**

→ Refer to page 5-4

Heater/Manual Air Conditioner

→ Refer to page 5-15



DRIVING CONTROLS

• Pedals	4-136
• Parking Brake Lever	4-137
• Gearshift Lever	4-138
• Selector Lever	4-141
• Model with Automatic Transmission	4-143
• Cruise Control	4-153
• Anti-lock Brake System (ABS)	4-158
• Electronic Braking force Distribution (EBD)	4-162
• Electronic Stability Control (ESC)	4-163
• Hill Start Assist	4-170
• Hill Descent Control	4-172
• Four Wheel Drive (4WD) Model	4-176
• Diesel Particulate Defuser (DPD)	4-184

Pedals

Manual transmission model

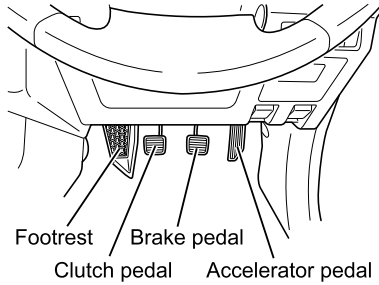

Automatic transmission model

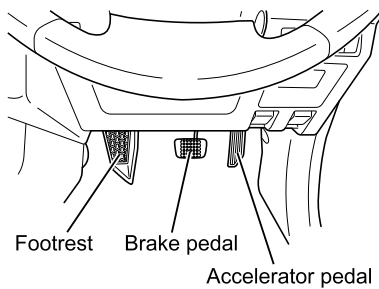

Sit in a correct driving position on the seat and operate the brake pedal and accelerator pedal with your right foot. To avoid accidentally pressing the wrong pedal, check the pedal positions and practice putting your foot on the desired pedal.

WARNING

- A can or bottle rolling on the floor may prevent brake pedal operation if it is caught under the pedal. This is very dangerous. A floor mat must be placed correctly. An incorrectly installed floor mat may hinder the free movement of each pedal.

Keep the Floor around the Driver's Seat Clean and Tidy → Refer to page 2-14
Making Sure the Floor Mats Laid Out Correctly → Refer to page 2-15

ADVICE

- Do not race the engine; engine components as well as fuel economy may be badly affected.
- If your vehicle has a manual transmission, do not drive with your foot resting on the clutch pedal. Doing so may damage the clutch.

Parking Brake Lever



CAUTION

- Although the brake system/parking brake warning light will come on if the parking brake is engaged, this does not mean the parking brake is fully engaged, so always make sure the lever is fully pulled up.
- Simply pressing the release button does not return the lever to its original position. You should always press the release button while pulling the parking brake lever up slightly.
- If the parking brake lever is not completely returned to its original position during driving, it may cause damage or a fire.
- In manual transmission models, if the vehicle is parked facing up a hill, place the gearshift lever in the "1 (1st)" gear, and if parked facing down a hill, place the lever in the "R (reverse)" gear. In addition, chocks must always be applied in either of these situations.
- Never park the vehicle on a steep slope.

Operation of Parking Brake

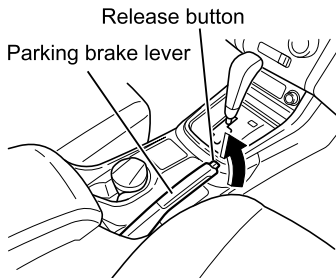

Brake system/parking brake warning light



When parking the vehicle, fully apply the parking brake lever without pressing the release button. The brake system/parking brake warning light in the instrument panel will come on when the lever is pulled up.

To release the parking brake, press the release button while raising the lever a little and then lower the lever. The brake system/parking brake warning light in the instrument panel will go out.

Gearshift Lever

Manual Transmission Model

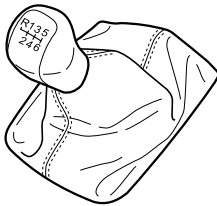
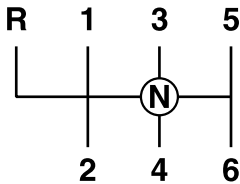

When making a gearshift, depress the clutch pedal fully.

When the gearshift lever is placed into "R (reverse)" position, the back up lights come on and a buzzer sounds.

**ADVICE**

- Make a shift into the reverse gear from a forward gear or into a forward gear from the reverse gear only when the vehicle has come to a complete stop. In addition, do not shift gears without fully depressing the clutch pedal. Otherwise, the transmission may be damaged.

**NOTE**

- As there is strong detent, apply ample force when shifting to the "R (reverse)" position.

Gear Shift Indicator (GSI)

Models with MID



Current gear position Recommend gear position

Models with LCD



Current gear position Recommend gear position

The GSI assists in gear selection to enable improved fuel economy when driving. In addition to displaying the current gear position on the instrument panel, it also displays the recommended gear position when there is a gear in which fuel economy would be improved. The GSI display can be switched between the following 3 patterns.

- The current gear position and recommended gear position are displayed. (GSI on)
- The current gear position and the recommended gear position are not displayed. (GSI off)
- Only the current gear position is displayed.

CUSTOMIZE (Gear Shift Indicator Display Setting) → Refer to page 4-55
GSI (Gear Shift Indicator) → Refer to page 4-69



CAUTION

- The recommended gear position displayed on the GSI is only a recommendation. It may be necessary to select a gear different than that displayed. Make sure to determine the shift position according to the actual road condition and surrounding situation.

**NOTE**

- The current gear position and the recommended gear position will not be displayed in the following conditions:
 - When the vehicle is stopped
 - When 4L (4WD low) is selected (models with 4WD)
 - When the gearshift lever is in the "N (neutral)" or "R (reverse)" position
- The current gear position may not be displayed correctly or the display may be delayed in the following conditions:
 - When the clutch is slipping
 - When the tires are slipping
 - When the tires installed are not of the specified size
 - When the tire pressure is insufficient
 - When accelerating suddenly or excessively







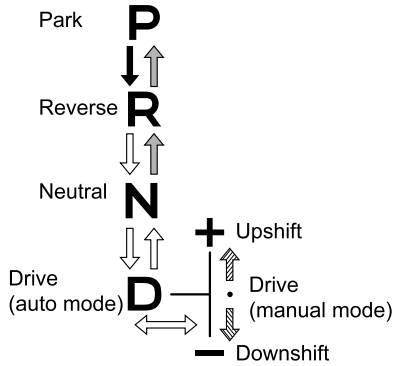
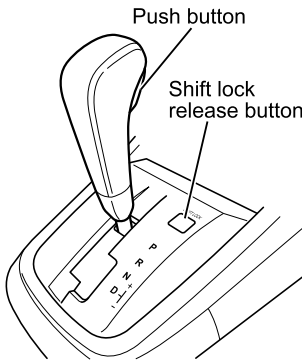

Selector Lever

Automatic Transmission Model

Move the selector lever to shift into each gear position.

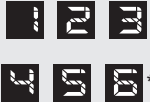

- : Operate the selector lever while pressing the push button with the brake pedal pressed.
- : Operate the selector lever while pressing the push button.
- : Operate the selector lever without pressing the push button.
- : Operate the selector lever without pressing the push button. The selector lever will return to the manual mode position when you release your hand after operating the lever in the direction of the arrow.

Selector lever position	Shift indicator in the instrument panel		Gear position
	Models with MID	Models with LCD	
P			Park: Used when parking and starting the engine.
R			Reverse: Used when backing up the vehicle.
N			Neutral: The engine can be started in this position but for safety reasons get in the habit of starting the engine with the selector lever in the "P" position.
D			Auto mode (automatic gearshift): The system automatically selects an optimum gear (1st to 5th gear in 5-speed automatic transmission model or 1st to 6th gear in 6-speed automatic transmission model) according to the vehicle speed.
+, -			Manual mode (manual gearshift): Manually selecting the "+" (upshift) or the "-" (downshift) position allows the driver to select the desired gear.

*: "6" is only for 6-speed automatic transmission model.



WARNING

- When pulling away, be sure to visually check the selector lever position and the shift indicator for safety reasons.
- If you always operate the selector lever while pressing the push button, it is possible to accidentally shift the lever to the "P" or "R" position in some cases.
- Get in the habit of shifting the selector lever from the "N" to "D" or "D" to "N" position without pressing the push button. Incorrect operation may cause a serious accident.



NOTE

- For safety reasons, the shift lock system operates to prevent shifting of the selector lever to any position other than "P" unless the brake pedal is depressed, the power mode is "ON" (models with passive entry and start system) or the starter switch is in the "ON" position (models without passive entry and start system). When pulling away, be sure to keep the brake pedal depressed as you operate the selector lever.

Shift Lock System → Refer to page4-151

Model with Automatic Transmission

An automatic transmission is a transmission system that allows the driver to move the vehicle from a standstill, drive the vehicle with gears changing and bring the vehicle to a stop by only using the selector lever, accelerator pedal and brake pedal, without using the clutch pedal. Make sure you fully understand the characteristics of the automatic transmission model and familiarize yourself with its operation.

Automatic Transmission Model

→ Refer to page 2-42

WARNING

- Fully depress the brake pedal to prevent the vehicle from moving even if it is stopped on a level road, and place the selector lever into "P" and securely set the parking brake as needed.
- Immediately after engine startup, while the air conditioner is running in models with an air conditioning system, the engine speed automatically rises, making creep stronger than it is at other times. Keep the brake pedal firmly pressed.

How to Use Automatic Transmission

CAUTION

- Before starting the engine, place the selector lever into "P", pull up the parking brake lever and then fully depress the brake pedal.
- When moving the selector lever from "P" into any other position, be sure to depress the brake pedal.
- Do not leave the driver's seat with the selector lever placed in "D" (auto mode or manual mode) or "R" while the engine is running. The vehicle may start moving. When leaving the driver seat, be sure to place the selector lever into "P" and securely set the parking brake.

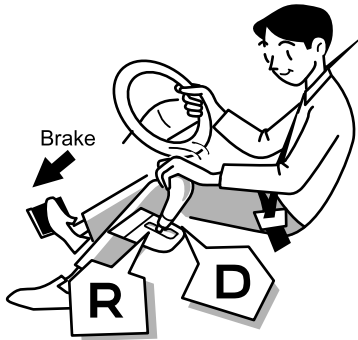

To Start Your Vehicle - on Normal Roads

1. Fully depress the brake pedal, and make sure that the selector lever is placed in "P" and that the parking brake lever is fully pulled up. Switch the power mode to "ON" (models with passive entry and start system) or turn the starter switch to the "ON" position (models without passive entry and start system).
2. Start the engine while fully depressing the brake pedal with your right foot. Place the selector lever into "D" (auto mode or manual mode) for forward movement or into "R" for backward movement.
3. Make sure that the shift indicator indicates "D" (auto mode or manual mode) for forward movement or "R" for backward movement, release the parking brake, release the brake pedal, and then slowly press the accelerator pedal. The vehicle starts moving as you depress the accelerator pedal further.

Models with MID



Models with LCD



**WARNING**

- When you move the selector lever to a position other than "P" or "N", creep will cause the vehicle to move. When pulling away, be sure to keep the brake pedal pressed as you operate the selector lever.
- When pulling away, be sure to visually check the selector lever position and the shift indicator for safety reasons. If you always operate the selector lever while pressing the push button, it is possible to accidentally shift the lever to the "P" or "R" position in some cases.
- Get in the habit of shifting the selector lever from the "N" to "D" or "D" to "N" position without pressing the push button. Incorrect operation may cause a serious accident.
- Do not operate the selector lever while pressing the accelerator pedal. Doing so is dangerous because the vehicle will suddenly move.
- Carefully operate the accelerator pedal because the speed is controlled only using the accelerator pedal when starting or accelerating the vehicle.
- Immediately after engine startup, while the air conditioner is running in models with an air conditioning system, the engine speed automatically rises, making creep stronger than it is at other times. Keep the brake pedal firmly pressed.

**NOTE**

- When the brake pedal is not pressed, the shift lock system operates and the selector lever cannot be shifted from "P" to any other position.
- On a snowy or icy road, by depressing the brake pedal you can make a standing start in the manual mode 2nd gear and move the selector lever to the "+" (upshift) position.

Shift Lock System

→ Refer to page 4-151

To Start Your Vehicle - on a Steep Slope

1. Firmly depress the brake pedal and make sure the parking brake lever is fully pulled up.
2. Place the selector lever into the "D" (auto mode or manual mode) position for forward movement or the "R" position for backward movement while fully depressing the brake pedal with your right foot.
3. Make sure that the shift indicator indicates "D" (auto mode or manual mode) for forward movement or "R" for backward movement, check the surrounding area to make sure it is safe to move the vehicle, ease your right foot off the brake pedal, and slowly press the accelerator pedal.
4. After you feel the vehicle start moving, slowly release the parking brake lever and pull away the vehicle.



WARNING

- When you move the selector lever to a position other than "P" or "N", creep will cause the vehicle to move. When pulling away, be sure to keep the brake pedal pressed as you operate the selector lever.
- Do not operate the selector lever while pressing the accelerator pedal. Doing so is dangerous because the vehicle will suddenly move.
- Carefully operate the accelerator pedal because the speed is controlled only using the accelerator pedal when starting or accelerating the vehicle.



ADVICE

- When the vehicle is stopped, do not keep depressing the accelerator pedal with the selector lever placed in the "D" (auto mode or manual mode) or "R" position while depressing the brake pedal. Doing so may cause a failure.
- When stopping the vehicle on a slope, be sure to fully apply the brakes. Keeping the vehicle stopped by depressing the accelerator pedal to produce a strong creeping effect may cause a failure.

To Drive on Normal Roads - Auto Mode

When you change the selector lever from "P" into "D" (auto mode), shifting takes place in the automatic mode. Check that "D" is displayed on the shift indicator.



CAUTION

- Do not place the selector lever into the "N" position while driving. The engine brake does not work at all, possibly causing an accident. Doing so may also cause a failure in the automatic transmission.

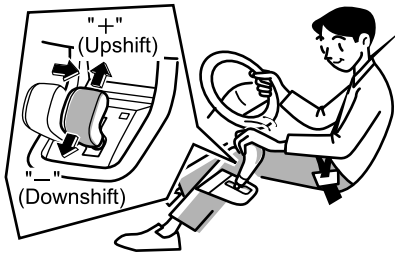

To Drive on Normal Roads - Manual Mode

When the selector lever is shifted from "D" (auto mode) to the manual mode position (shifted to the right side) while the vehicle is stopped or being driven, the mode changes to the manual mode and the gears can be shifted manually as with a manual transmission model.

- When changing the gear, move the lever towards the "+" (upshift) or "-" (downshift) direction as necessary to select the desired gear. The currently selected gear ("1" to "5" in 5-speed automatic transmission model or "1" to "6" in 6-speed automatic transmission model) is displayed on the shift indicator.
- Gears are not automatically shifted in the manual mode. To return to the auto mode, place the selector lever into the "D" (auto mode) position. Make sure that "D" is displayed on the shift indicator.



ADVICE

- Shift into the gear that is appropriate for the vehicle speed. If an inappropriate gear shift position is selected, a warning buzzer will sound and the shift will not occur.
- Driving using an inappropriate gear in the manual mode will result in a failure of the transmission system. In particular, avoid selecting higher gears when driving uphill or towing. Doing so will cause overheating.



NOTE

- The gear is automatically shifted down to the 1st gear when the vehicle is stopped.

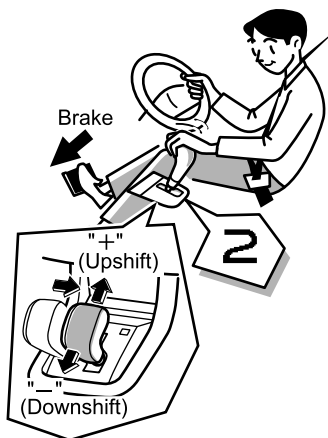

2nd Start Mode on a Snowy or Frozen Road - Manual Mode

Use 2nd start mode only when driving on slippery road conditions due to snow, ice, etc.

1. Depress the brake pedal and stop the vehicle.
2. Shift the selector lever from the "D" (auto mode) position to the manual mode position (shifted to the right side). Press the selector lever forward to "+" (upshift).
3. Make sure that the shift indicator display changes from "1" to "2".
4. To disengage the 2nd start mode, shift the selector lever to the "D" (auto mode) position or select a gear other than "2".



ADVICE

- Driving during normal road conditions using 2nd start mode will cause the automatic transmission fluid temperature to rise, leading to breakdown.

To Accelerate (Auto Mode)

When you depress the accelerator fully while driving with the selector lever in the "D" (auto mode) position, the transmission automatically shifts to a lower speed gear according to the vehicle speed and the engine speed rises to enable sufficient acceleration.

Uphill/Downhill Transmission Control System

On steep uphill grades or when towing a heavy load, the system senses a lack of engine torque in the upper gears and prevents upshifting or forces downshifting. This feature provides more suitable gear selection for driving uphill and unnecessary gear changes are eliminated.

On steep downhill grades, the system automatically downshifts when the service brake is applied as a trigger. Engine braking power is utilized to reduce the service brake load.

Lock-up Clutch Slip Control System

This system provides increased transmission efficiency and fuel economy.

The system automatically operates to reduce torque converter slip loss during moderate acceleration at low speed and to increase the effects of engine fuel-cut when coasting.



NOTE

[What is lock-up clutch]

- It is a device that raises transmission efficiency in the 2nd to 5th gear for 5-speed automatic transmission model or in the 3rd to 6th gear for 6-speed automatic transmission model when a certain speed is reached, and improves fuel efficiency.
- The lock-up clutch will be released when the accelerator pedal is pressed forcefully.

To Stop the Vehicle

When stopping the vehicle temporarily, firmly press the brake pedal with the selector lever in the "D" (auto mode or manual mode) position.



WARNING

- Immediately after engine startup, while the air conditioner is running in models with an air conditioning system, the engine speed automatically rises, making creep stronger than it is at other times. Keep the brake pedal firmly pressed.
- When the vehicle is likely to be stopped for a long time, place the selector lever into the "N" position, fully depress the brake pedal and firmly set the parking brake. When the selector lever is placed in the "D" position, the torque converter of the transmission generates heat and the oil temperature of the automatic transmission fluid increases.



CAUTION

- When leaving the driver's seat, be sure to place the selector lever into the "P" position, make sure that the shift indicator displays "P" and firmly set the parking brake.
- Do not race the engine while the vehicle is stopped. If the selector lever is placed in any position other than "P" or "N", the vehicle will suddenly move and it may cause an accident.

**ADVICE**

- When the vehicle is stopped, do not keep depressing the accelerator pedal with the selector lever placed in the "D" (auto mode or manual mode) or "R" position while depressing the brake pedal. Doing so may cause a failure.
- When stopping the vehicle on a slope, be sure to fully apply the brakes. Keeping the vehicle stopped by depressing the accelerator pedal to produce a strong creeping effect may cause a failure.

**NOTE**

- When stopping the vehicle to wait for a traffic light, it is recommended that you place the selector lever into the "N" position for improved fuel economy.

To Start Your Vehicle After Stopping

When starting the vehicle after stopping, visually check the selector lever position and the shift indicator and start the vehicle by slowly pressing the accelerator pedal.

**When Parking Your Vehicle**

1. Set the parking brake while depressing the brake pedal with your right foot.
2. Place the selector lever into the "P" position, make sure that the shift indicator displays "P", and then slowly ease your right foot off the brake pedal.
3. In models with passive entry and start system, stop the engine and switch the power mode to "OFF". When the selector lever is not placed in the "P" position, the shift lock system operates and the power mode cannot be switched to "OFF".
In models without passive entry and start system, stop the engine and remove the key. When the selector lever is not placed in the "P" position, the shift lock system operates and the key cannot be removed.

 **WARNING**

- Do not leave the vehicle while the engine is running. If the selector lever is placed in any position other than "P" or "N" position, creep may cause the vehicle to move or the vehicle may suddenly move by accidentally pressing the accelerator pedal when getting in the vehicle. While the air conditioner is used in models with an air conditioning system, the engine speed rises when the air conditioner operates and the vehicle may start moving even when it is stopped temporarily.
- When parking the vehicle, be sure to use the parking brake together with the "P" position of the selector lever. Avoid parking only with the selector lever placed in the "P" position.
- When parking the vehicle on a slope, place the selector lever into the "P" position and chock the tires.

Shift Lock System**When Starting Your Vehicle**

The selector lever cannot be operated from the "P" position to any other position when the brake pedal is not depressed. Be sure to operate the lever while depressing the brake pedal.

When Parking Your Vehicle

In models with passive entry and start system, the power mode cannot be switched to "OFF". In models without a passive entry and start system, the key cannot be removed unless the selector lever is securely placed in the "P" position (key interlock system). Be sure to place the selector lever in the "P" position when parking the vehicle.

 **NOTE**

[Use the shift lock system correctly]

- The shift lock system is a system for safety to prevent incorrect operation of the automatic transmission model. Use it correctly and drive safely.

When the Selector Lever Cannot be Operated from the "P" Position to Any Other Position

When the selector lever cannot be operated from the "P" position to any other position after the engine starts, perform the following checks.

- Check whether the brake pedal is firmly depressed.
When the brake pedal is not pressed, the shift lock system operates and the selector lever cannot be shifted from "P" to any other position.
- Check whether the parking location is on a slope.
When the vehicle is parked on a downslope, operation of the push button of the selector lever can become heavy. In that case, it can be operated smoothly when pressing the push button while pressing the selector lever toward the front of the vehicle.

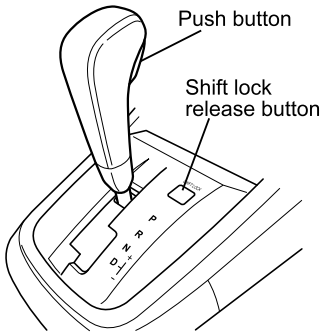

Shift Lock Release

When the selector lever cannot be operated from the "P" position to any other position even after checking depression of the brake and the condition of the parking location and performing the operation as above, perform the following operations.

1. Fully depress the brake pedal and securely set the parking brake.
2. Press the shift lock release button.
3. Press the push button and operate the selector lever while pressing the shift lock release button.

WARNING

- When the selector lever cannot be operated from the "P" position to any other position even after performing the operation above repeatedly, the shift lock system may have a failure. Have your vehicle inspected at the nearest Isuzu Dealer at once.

Cruise Control

The cruise control function allows you to drive the vehicle at a constant speed without operating the accelerator pedal. Cruise control can be used at vehicle speeds of approximately 40 km/h (25 MPH) or higher. This function should only be used when driving without frequent starting and stopping, such as when driving on an expressway.



WARNING

- Do not use the cruise control function on the following roads, where using it could be dangerous.
 - A road with a heavy traffic, such as an urban road
 - A road that includes sharp curves and steep downhill slopes
 - An icy, snowy or otherwise slippery road



CAUTION

- Remember that taking your foot off the accelerator when the cruise control is engaged will not reduce vehicle speed. When going up or down hills (particularly when towing) it is possible for the vehicle to gain or lose speed, even though the cruise control is engaged. If this happens while going up a hill, depress the accelerator pedal to maintain the desired speed. If going down a hill, depress the brake pedal, which will both disengage the cruise control and slow down the vehicle.
- If you feel any abnormality when using cruise control, cancel cruise control with the cruise control main switch and have your vehicle inspected as soon as possible at your Isuzu Dealer.

Setting to Your Desired Vehicle Speed

Cruise control main switch

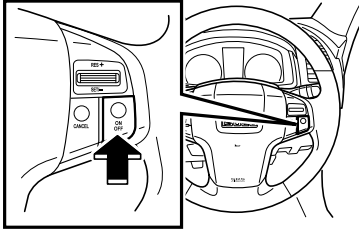

1. Press the cruise control main switch to set it to "ON". The cruise control main indicator light will come on. In models with an MID, the cruise control main indicator light comes on after the "CRUISE MAIN POWER" is displayed on the MID for approximately 3 seconds and then goes out.

Cruise control main indicator light



CRUISE MAIN POWER
(models with MID)

CRUISE
MAIN POWER

Cruise control set switch

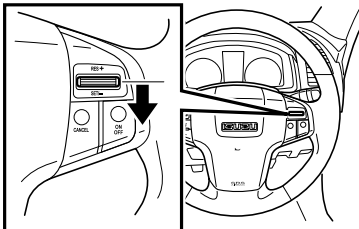

2. Use the accelerator pedal to adjust the vehicle to the desired speed above approximately 40 km/h (25 MPH). Upon reaching the desired speed, operate the cruise control set switch. The vehicle speed at the moment you operate the switch is set in the system, enabling you to drive with the set speed automatically maintained without using the accelerator pedal.

Cruise control set indicator light



CRUISE SET (models with MID)

CRUISE SET

At the same time the cruise control set indicator light comes on. In models with an MID, the cruise control set indicator light comes on after the "CRUISE SET" is displayed on the MID for approximately 3 seconds and then goes out.

Accelerating during Cruise Control Driving

If you want to accelerate temporarily to pass another vehicle while driving using the cruise control, depress the accelerator pedal. When you release the accelerator pedal, the speed returns to the original set vehicle speed.

Changing the Cruise Control Speed Setting

Cruise control resume switch

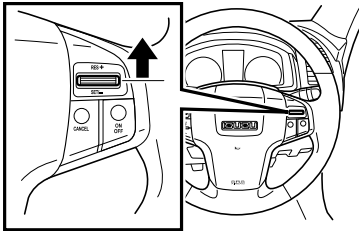

When Increasing Vehicle Speed

When the cruise control resume switch is operated, the speed increases while the switch is held.

After the speed is increased to the desired vehicle speed, and the switch is released, the speed is set at the increased vehicle speed. If you want to increase the speed quickly, depress the accelerator pedal and accelerate to the desired vehicle speed.

Then, operate the cruise control set switch.

When Increasing Vehicle Speed Slightly

If the cruise control resume switch is operated and released immediately, the set vehicle speed increases 1 km/h (0.6 MPH) per operation.

Cruise control set switch

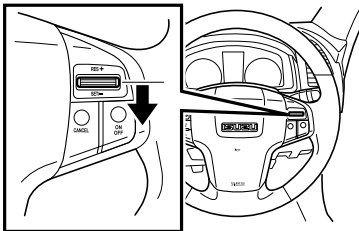

When Decreasing Vehicle Speed

When the cruise control set switch is operated, the speed decreases while the switch is held.

After the speed is decreased to the desired vehicle speed, and the switch is released, the speed is set at the decreased vehicle speed. If you want to decrease the speed quickly, depress the brake pedal to cancel cruise control and decelerate to the desired vehicle speed. Then, operate the cruise control set switch.

When Decreasing Vehicle Speed Slightly

If the cruise control set switch is operated and released immediately, the set vehicle speed decreases 1 km/h (0.6 MPH) per operation.

When Canceling Cruise Control

Cruise control main switch

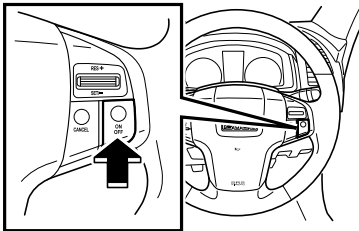

Cruise control cancel switch

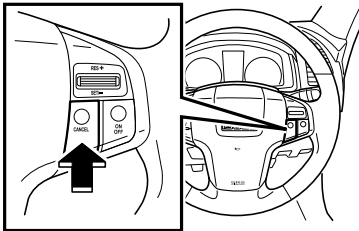

Press the cruise control main switch again to set it to "OFF". The cruise control main indicator light will go out.

The cruise control is canceled in the following cases.

- When the brake pedal is depressed.
- When depressing the clutch pedal (manual transmission model).
- When the vehicle speed decreases to approximately 40 km/h (25 MPH) or less.
- When there is an abnormality in the engine control system.
- When shifting gears.
- When operating the cruise control cancel switch.
- When the vehicle has been temporarily stopped and the selector lever has been placed in the "N" position (automatic transmission model).
- When the electronic stability control (ESC) or traction control system (TCS) is activated.

**ADVICE**

- When not using the cruise control, be sure to turn it off.
- When switching the power mode to "ACC" (models with passive entry and start system) or turning the starter switch to "ACC" (models without passive entry and start system), reset the cruise control after pressing the cruise control main switch to turn off the cruise control.

When Returning to Cruise Control Driving

If you have canceled cruise control under the following conditions, you can return to the cruise control driving condition before cancellation when you operate and release the cruise control resume switch. The moment the resume switch is released, the cruise control set indicator light comes on.

- When depressing the brake pedal.
- When shifting gears.
- When operating the cruise control cancel switch.

Anti-lock Brake System (ABS)

Wheels may be locked and slip during sudden braking or braking on a slippery road surface such as a snowy road. ABS is a device to prevent the wheels from by detecting a slippery condition during braking and to secure directional stability and handling stability of the vehicle. ABS is only to assist in slippery conditions and will not prevent an accident if you exceed safe driving speeds for road conditions. Always drive safely.



CAUTION

- The braking distance on slippery road surfaces is longer than that on a normal dry paved road even with an ABS-equipped vehicle. In addition the braking distance can be slightly longer in deep snow and on a gravel road when ABS is activated. Therefore, always keep in mind the road condition and tire condition (type of tires and worn condition), observe safe driving habits and drive the vehicle while keeping a proper distance between vehicles.
- ABS does not prevent accidents if you do not drive safely. Drive the vehicle at a safe speed.
- Install tires of the specified size, same brand and same tread design (including winter tires) on all wheels. If different tires are installed, the braking distance becomes longer and directional control stability of the vehicle decreases. This is very dangerous.
- Steering during sudden braking (when the ABS is working) will feel slightly different than it does when the brakes are not applied. Operate the steering wheel carefully keeping this in mind.



ADVICE

- Driving in sand or on a muddy road may adversely affect the brakes and ABS sensors. Wash the vehicle to remove sand and mud after operating the vehicle in sandy or muddy conditions.
- Before washing the vehicle, provide necessary protection to prevent water from being splashed on the ABS components (sensors and actuators). Especially when using high-pressure washing, be careful not to allow water to be directly sprayed onto the ABS components and their harness connectors.

**NOTE**

[These are not signs of ABS malfunction]

- Immediately after the engine is started, a motor sound may be heard from the engine compartment. This sound is from a self-check by the ABS. In addition, you may also feel some vibration if the brake pedal is pressed at this time.
- When ABS is operating, vibration is felt on the brake pedal and steering wheel and you may hear the system operating. This is normal when ABS is properly operating.
- ABS is more likely to be activated when the brake is applied during cornering or driving over a bump. This is because inside wheels or wheels that have gone over a bump tend to lock.
- ABS is not activated immediately after starting the vehicle. It is activated only when the vehicle speed reaches approximately 10 km/h (6 MPH). ABS operation is inactive when the vehicle speed reduces to approximately 5 km/h (3 MPH).

ABS Operation Indications and Signs

ABS warning light

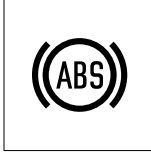

Operation Indications of ABS

When the power mode is switched to "ON" (models with passive entry and start system) or the starter switch is turned to the "ON" position (models without passive entry and start system), the ABS warning light comes on and then goes out in approximately 3 seconds. The ABS is normal if the warning light goes out.

Operation Signs of ABS

When ABS is activated, slight vibration is generated on the brake pedal and steering wheel, and an operating sound can be heard from the ABS equipment.



NOTE

- If the ABS warning light does any of the following, the ABS may be faulty. Please contact the nearest Isuzu Dealer.
 - If the ABS warning light comes on during driving.
 - The light does not come on when the power mode is switched to "ON" (models with passive entry and start system) or the starter switch is turned to the "ON" position (models without passive entry and start system).
- Even if a problem has occurred with the ABS, the regular brakes will still work normally. However, ABS will not operate.

ABS Warning Light

→ Refer to page 4-75

Precautions for Driving an ABS-Equipped Vehicle

ABS is not a device that enables driving and stopping under conditions exceeding safe driving limits. Always drive safely.



CAUTION

- When braking suddenly, continue pressing brake pedal hard so that the ABS can take effect.
- When braking suddenly, do not pump the brakes (pushing and releasing the brake pedal little by little). Pumping brakes will increase the braking distance.
- The braking distance on slippery road surfaces is longer than that on a normal dry paved road even with an ABS-equipped vehicle. When ABS is activated in the following road surface conditions, the braking distance may be slightly longer compared to that of vehicles not equipped with an ABS. Therefore, always be aware of the road and tire condition (tire type and wear condition), observe safe driving habits and drive the vehicle while keeping a safe following distance.
 - When driving on a gravel road, or a road with a deep snow covering.
 - When tire chains are used.
 - When driving over road joints or bumps such as light reflectors on the road.
 - When driving on a bumpy road, stone-paved road or track.
 - When driving over an iron plate or manhole lid.
- ABS does not work for wheel skid during a standing start, acceleration and cornering which do not involve braking. On a very slippery icy road, tires may lose grip and steering wheel operation may not be able to control the vehicle's direction, resulting in very unstable driving. Always drive the vehicle observing a safe speed well matched with both road surface and tire conditions, and avoid sudden braking.
- If powerful engine braking is applied on a very slippery icy road, the drive wheels may be locked (the ABS then does not work), resulting in loss of vehicle control. If this happens with a manual transmission vehicle, disengage the clutch or place the gearshift lever into the "N" position to prevent engine braking from acting on the drive wheels. Then, drive the vehicle with the gearshift lever placed in an appropriate gear.
- When ABS is activated, a slight vibration (especially when the road surface is different between right and left wheels) and pulling may be felt on the brake pedal and steering wheel. In addition, an operating sound is produced from the ABS actuators. This does not indicate any abnormal condition. Stay calm and operate the steering wheel properly.

Electronic Braking force Distribution (EBD)

EBD is a function that uses the ABS to distribute braking force ideally between the front and rear wheels in order to compensate for changes in load conditions or any shift of the load due to acceleration or deceleration, thus preventing premature locking of the rear wheels.



CAUTION

- If a problem should occur with the EBD function, the ABS warning light and the brake system/parking brake warning light will come on simultaneously.
- The rear wheels will lock more easily if there is a problem with the EBD function. Have it checked and serviced at the nearest Isuzu Dealer as soon as possible.



NOTE

- When the EBD operates, the brake pedal may push back slightly or you may hear a sound similar to that generated by the ABS when operational. Neither of them indicate any abnormal condition.

Electronic Stability Control (ESC)

The ESC improves safety and a vehicle's stability. The ESC controls engine power and applies the brakes to the wheels that need it in order to suppress wheelspin when starting or accelerating on slippery road surfaces, maintain drive power, prevent skidding to the side, and improve vehicle stability. The ESC has various sensors that detect rapid changes in the vehicle conditions while driving. The traction control system (TCS) controls engine power and applies the brakes to the wheels that need it in order to suppress wheelspin when starting or accelerating. Normally, both the ESC and TCS activate automatically when the engine is started. When the 4WD switch is set to 4L (4WD low) (models with 4WD), the ESC OFF indicator light comes on, and the ESC and TCS engine power control function will not activate. However, in this case TCS brake control function will still activate.

By using the ESC OFF switch, the ESC can be canceled (operation stopped status) or only the function of the TCS can be canceled (operation stopped status).



CAUTION

- When the ESC is operated, the ESC warning light flashes.
- The ESC warning light will also flash when only the TCS function is operating.
- When the ESC warning light is flashing, the road surface is slippery or acceleration is too fast. Loosen pressure on the accelerator pedal and drive conservatively.
- The ESC warning light may also flash when fully depressing the accelerator pedal on roads that are not slippery such as dry asphalt roads. This is a normal condition that predicts slipping and operates control.
- Even with an ESC-equipped model, when driving on a snowy or icy road, install tire chains or winter tires, and carefully drive the vehicle. The ESC is not a device for drastically improving the vehicle stability when driving or starting performance, so drive carefully on snowy or icy roads.
- When tire chains are installed, it may be easier for you to start the vehicle to move on an icy slope if just the TCS is canceled. Be aware, however, that TCS deactivation will result in reduced vehicle stability.
- Install tires of the specified size, same brand, same type and same tread design (including winter tires) on all wheels. In addition, do not install or use tires with significantly varying degrees of wear. If tires other than the specified size, different types, or tires with significantly varying degrees of wear are used, the ESC may not operate properly.
- If the tire diameter is different such as when installing tire chains or a spare tire, the ESC may not operate properly.

CAUTION (Continued)

CAUTION (Continued)

- If suspension-related parts, brake-related parts, or engine-related parts are replaced with parts other than Isuzu genuine parts or modified, the ESC may not operate properly.
- Be sure to consult with your Isuzu Dealer for replacement or repair of the steering wheel or steering-related parts. There is a sensor on the steering wheel that detects driving operation conditions, and the ESC may not operate properly if the steering wheel center position is misaligned.
- Do not tow the vehicle with the power mode in "ON" (models with passive entry and start system) or the starter switch in the "ON" position (models without passive entry and start system) with just the front wheels or rear wheels raised. The ESC may operate and cause an accident.

**NOTE**

[These are not signs of ESC malfunction]

- Immediately after the engine is started, a motor sound may be heard from the engine compartment. This sound is from a self-check by the ESC. In addition, you may also feel some vibration if the brake pedal is pressed at this time.
- When the ESC is operating, the brake pedal movement may wiggle or feel tight. In addition, the vehicle body may vibrate or you may hear operating sounds. This is normal for ESC operation.
- The ESC will not operate immediately after starting until the vehicle reaches approximately 15 km/h (9 MPH).

ESC OFF Switch

When getting unstuck from mud or fresh snow with the ESC and TCS operating, the engine output may not rise even when the accelerator pedal is depressed, making getting unstuck difficult. In times like this, pressing the ESC OFF switch will make getting unstuck easier. The ESC can be turned off using the ESC OFF switch, or just the TCS (function for suppressing tire spinning when starting or accelerating) in the ESC system can be turned off.

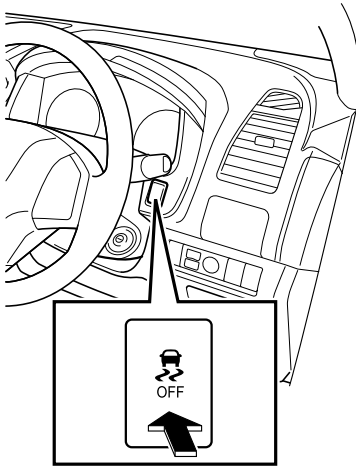

TCS OFF indicator light

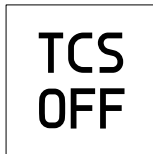

When Canceling the TCS

When the ESC is active after the engine is started, press the ESC OFF switch for approximately 1 second to cancel the TCS and cause the TCS OFF indicator light in the instrument panel to turn on. When the switch is pressed again for approximately 1 second, the TCS function turns back on. When the 4WD switch is set to 4L (4WD low) (models with 4WD), press the ESC OFF switch for approximately 5 second to cancel the TCS and cause the TCS OFF indicator light in the instrument panel to turn on. When the switch is pressed again for approximately 1 second, the TCS function turns back on.

CAUTION

- When you turn off the TCS, it will not be available to assist you in slippery driving conditions. Always use caution when driving on slippery roads.
- Be sure to enable the TCS during normal driving.
- The ESC will activate even if the TCS is off. However, when the 4WD switch is set to 4L (4WD low) (models with 4WD), the ESC will not activate.

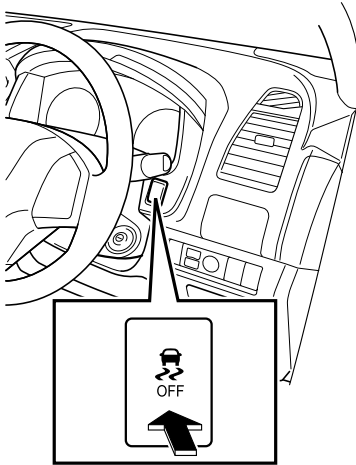

ESC OFF indicator light

**NOTE**

- If the engine is turned off and then restarted again while the TCS is off, the TCS will be automatically reactivated.

When Canceling the ESC

When the ESC is active after the engine is started, press the ESC OFF switch for approximately 5 seconds to cancel the ESC and cause the ESC OFF indicator light in the instrument panel to turn on. When the switch is pressed again for approximately 1 second, the ESC function turns back on.

**CAUTION**

- When you turn off the ESC, it will not be available to assist you in slippery driving conditions. Always use caution when driving on slippery roads.
- Be sure to enable the ESC during normal driving.
- When the ESC is turned off, the TCS will also be turned off, thus be careful when driving on slippery roads.

**NOTE**

- If the engine is turned off and then restarted again while the ESC is off, the ESC will be automatically reactivated.
- When the 4WD switch is set to 4L (4WD low) (models with 4WD), the ESC will be canceled automatically.

ESC Operation Check, Operation, Error

ESC warning light



TCS OFF indicator light

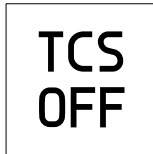

ESC OFF indicator light



ESC Operation Check

When the power mode is switched to "ON" (models with passive entry and start system) or the starter switch is turned to the "ON" position (models without passive entry and start system), the ESC warning light, TCS OFF indicator light, and ESC OFF indicator light turn on before going out after approximately 3 seconds. The ESC is normal if the warning light and indicator light go out.

When the ESC is Operational

When the ESC is operating, the ESC warning light flashes.

ESC Faulty

When the ESC warning light does any of the following, the ESC may be faulty. Please contact the nearest Isuzu Dealer.

- The ESC warning light remains on while driving.
- The TCS OFF indicator light and ESC OFF indicator light turn on while driving (when the ESC OFF switch is not operated).
- The ESC warning light, TCS OFF indicator light, and ESC OFF indicator light do not turn on when the power mode is switched to "ON" (models with passive entry and start system) or the starter switch is turned to the "ON" position (models without passive entry and start system).



NOTE

- If the ESC is faulty, it does not interfere with normal driving. However, the ESC will not function.

Driving Precautions for Vehicles Equipped with ESC

**CAUTION**

- The ESC is not a device that enables driving under conditions exceeding safe limits. Always drive safely.
- Always concentrate on driving safely and do not be overconfident just because the vehicle is equipped with the ESC, so do not drive too fast and turn the steering wheel too sharply.
- The ESC does not increase the road grip of tires although it controls slipping and sliding of vehicles and improves the vehicle stability on a slippery road surface during starting and acceleration when compared to a model without ESC. On an icy or otherwise slippery road, the grip of the tires decreases which also reduces steering control, resulting in unstable vehicle behavior. Always drive the vehicle observing a safe speed well matched to the road surface and tire conditions, and also avoid speeding.
- The ESC is a system for maintaining drive power and vehicle stability. Turn the system on even when it is not needed. When the system is turned off, drive carefully at a safe speed well matched to the road surface.
- Even if ESC is equipped, avoid sudden operation of the accelerator pedal, clutch pedal (manual transmission models) and steering wheel. Especially when starting the vehicle on a slippery road, start up slowly as you would in a vehicle without ESC.
- When the ESC is operated, the ESC warning light flashes.
- The ESC warning light will also flash when only the TCS function is operating.
- When the ESC warning light is flashing, the road surface is slippery or acceleration is too fast. Loosen pressure on the accelerator pedal and drive conservatively.
- The ESC warning light may also flash when fully depressing the accelerator pedal on roads that are not slippery such as dry asphalt roads. This is a normal condition that predicts slipping and operates control.
- Even with an ESC-equipped model, when driving on a snowy or icy road, carefully drive the vehicle, and install tire chains or winter tires.
- When tire chains are installed, it may be easier for you to start the vehicle to move on an icy slope if just the TCS is canceled. Be aware, however, that TCS deactivation will result in reduced vehicle stability.
- Do not install a commercially available limited slip differential (LSD). The ESC may not operate properly.

**NOTE**

- When the ESC is operating, the brake pedal movement may wiggle or feel tight. In addition, the vehicle body may vibrate or you may hear operating sounds. This is normal for ESC operation.
- If there is significant wear or degradation on parts related to the suspension, tires, brakes, etc., the ESC warning light may turn on. In such cases, the ESC may not function properly.
- The ESC warning light may turn on when the vehicle is on a turntable at the entrance of a parking garage or on a moving object, etc. In such cases, re-start the engine after the vehicle has left the turntable.
- The ESC warning light may turn on when driving on roads with extreme inclines (the banks seen on race tracks, etc.). In such cases, the ESC may not function properly, so do not drive on such roads.
- The ESC warning light may turn on when the battery cables are disconnected or the battery voltage is low. The ESC function turns off while the ESC warning light is on, but the ESC warning light will turn off by driving the vehicle normally for a while, then the ESC function will resume. If the ESC warning light remains on even after driving for a while, contact the nearest Isuzu Dealer.

Hill Start Assist

The hill start assist works to assist the driver by lessening the vehicle roll-back that occurs when the vehicle pulls away on steep slopes. When the driver's foot is moved from the brake pedal to the accelerator pedal, the brakes are held in place for a maximum of approximately 2 seconds.

The hill start assist will operate when all the following conditions are met:

- When the vehicle pulls away in the forward or reverse directions on a slope
- When the vehicle is stopped with the brake pedal firmly depressed
- When the parking brake is released



WARNING

- The hill start assist is not for stopping the vehicle on slopes. The vehicle may start moving if the pressure applied to the brake pedal is decreased when the vehicle is stopped on a slope, even if the system is operating normally. Because of this, it is necessary to continue to firmly depress the brake pedal when the vehicle is stopped.
- Do not overestimate the effectiveness of the hill start assist. Doing so may result in sudden vehicle movement when pulling away, possibly leading to an accident. Pull away only after checking the vehicle's surroundings and with the proper procedure.
- Pull away immediately after removing your foot from the brake pedal. If the vehicle were to begin rolling back due to inertia on slopes, etc., the engine may stall, brake effectiveness will decrease, and the steering wheel will become heavy, possibly leading to an accident.



CAUTION

- The hill start assist may not operate when the ESC warning light comes on. Be especially careful if the ESC warning light is on when pulling away.
- The vehicle may roll-back due to the vehicle load when driving on extremely sharp slopes or poor road surfaces (such as those that are icy or muddy).
- The hill start assist may not operate if the brake pedal is not sufficiently depressed when the vehicle is stopped, or depending on the number of passengers or cargo weight.
- The hill start assist cannot lessen vehicle roll-back for more than 2 seconds.

**NOTE**

- The following will occur when the hill start assist operates and do not indicate a malfunction:
 - The feeling of the brake pedal when depressed will change.
 - The brake pedal will vibrate.
 - Sounds will be generated from the brake pedal.

Hill Descent Control

Hill descent control is a system that assists in driving stability by controlling the brakes to maintain a consistently low speed when descending down steep slopes or on slippery off-road surfaces in which only the engine brake itself is insufficient. When the hill descent control is in operation, it is possible to adjust vehicle speed by depressing the accelerator pedal or the brake pedal.



CAUTION

- Do not overly rely on the hill descent control system. When descending on extremely steep slopes, frozen road surfaces, or muddy roads, or depending on cargo load, it may be difficult to maintain a constant speed. Because an accident may unexpectedly occur in such situations, depress the brake pedal as necessary.
- The temperature of the brake system may rise when used repeatedly for extended periods of time, resulting in the hill descent control being deactivated.



NOTE

- The following may occur during hill descent control operation, but do not indicate an abnormality.
 - Motor operation sounds, etc. can be heard from the engine room during operation
 - When the brake pedal is depressed, there is more resistance than normal or pedal feeling is strange

Operating the Hill Descent Control

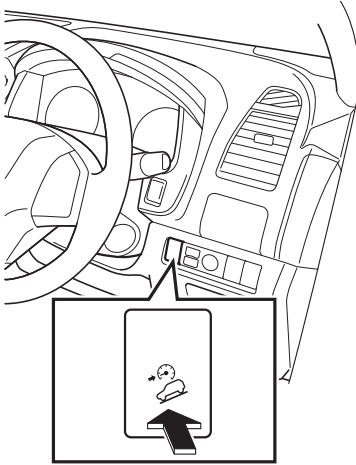

**Hill descent control indicator light
(models with MID)**



**Hill descent control indicator light
(models with LCD)**

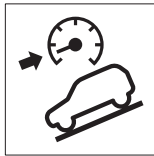

1. The hill descent control will be activated when the hill descent control switch is pressed.

When the hill descent control is activated, the hill descent control indicator light located in the instrument panel will come on.

2. In manual transmission models, place the gearshift lever in a position other than "N" and drive the vehicle. In automatic transmission models, place the selector lever in a position other than "P" or "N" and drive the vehicle.



NOTE

- In manual transmission models, gearshift lever positions "1", "2" or "R" are recommended. In automatic transmission models, selector lever positions "D" or "R" are recommended.

3. When driving, the hill descent control will operate when all of the following conditions are met.

When the hill descent control is in operation, the hill descent control indicator light will flash.

- Steep slope
- Vehicle speed is between a very low speed and approximately 30 km/h (19 MPH)
- Accelerator pedal is not depressed

**NOTE**

- The system will automatically control the brakes to prevent the vehicle speed at the time of hill descent control operation from being exceeded.
- When the hill descent control is in operation, the brake lights will operate.
- When the hill descent control is in operation, it is possible to depress the brake pedal to decrease speed or to depress the accelerator to increase to a vehicle speed of 30 km/h (19 MPH) or less.
- When the hill descent control is activated, the hill descent control may also operate when traveling on a flat road or making a U-turn.

Deactivating the Hill Descent Control

CAUTION

- When the ABS, EBD, ESC, or TCS are in operation, the hill descent control will be deactivated. When this happens, adjust the vehicle speed by depressing the brake pedal.
- When the temperature of the brake system rises, the hill descent control may be deactivated.

Hill descent control indicator light (models with MID)



Hill descent control indicator light (models with LCD)

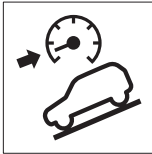

When the hill descent control is in operation, hill descent control will return to the activated state and the hill descent control indicator light will come on when any of the following conditions are met:

- When the selector lever is placed in the "P" or "N" position (automatic transmission model)
- When the slope gradient becomes less steep
- When the vehicle speed exceeds approximately 30 km/h (19 MPH)
- When the vehicle stops

When the hill descent control is in operation or activated state, hill descent control will be deactivated and the hill descent control indicator light will go out when any of the following conditions are met:

- When the hill descent control switch is pressed
- When the vehicle speed exceeds approximately 50 km/h (31 MPH)
- When there is an abnormality in the hill descent control related systems or the brake system

ESC warning light



NOTE

- When there is an abnormality in the hill descent control related systems or the brake system, the ESC warning light will come on.

Four Wheel Drive (4WD) Model

2WD and 4WD ("4H (4WD high)" or "4L (4WD low)") operation can be selected using the 4WD switch. Change them according to the driving conditions.

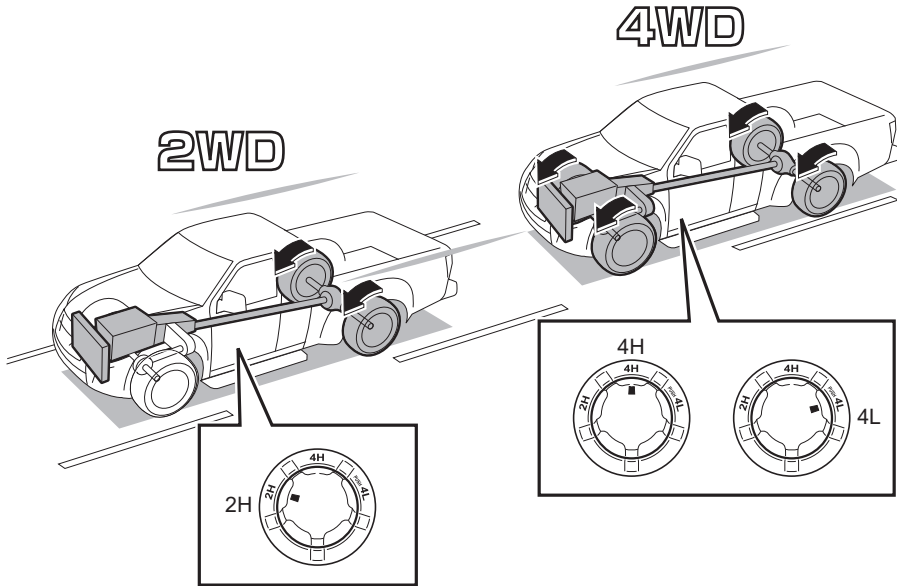
**CAUTION**

- Even a 4WD vehicle does not exempt you from safe driving practices. Operate the accelerator pedal, steering wheel and brake pedal with the same level of caution as when driving a standard rear-wheel drive vehicle.
- Install tires of the specified size, same brand and same tread design (including winter tires) on all wheels.

4WD Switch

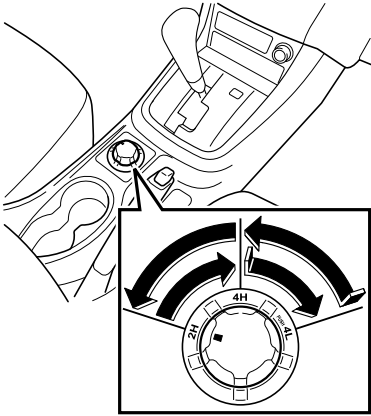

Use the 4WD switch to select 2WD or 4WD ("4H (4WD high)" or "4L (4WD low)").



CAUTION

- Driving in 4WD mode on dry, well-paved roads can accelerate wearing of the front tires and reduce fuel efficiency. As this action can also increase vehicle noise levels and lead to drive system damage, 2WD should always be used under these driving conditions.



NOTE

- When the vehicle speed, engine speed, gearshift lever (manual transmission models) or the selector lever (automatic transmission models) position, or clutch pedal operating condition (manual transmission models) conflict with the changing conditions and when there is an abnormality in 4WD system, a warning buzzer sounds to alert you that switching is not possible.
- In the event that the 4WD indicator light or 4WD low indicator light fail to either go off or come on even when the 4WD switch is operated, have the vehicle inspected and serviced at your Isuzu Dealer.
- When the CHECK 4WD warning light is on, have the vehicle inspected and serviced at your Isuzu Dealer.

4WD Indicator Light

→ Refer to page 4-107







4WD Low Indicator Light

→ Refer to page 4-108

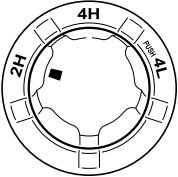
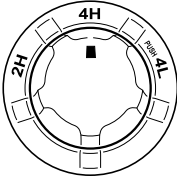
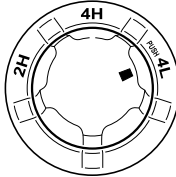
CHECK 4WD Warning Light

→ Refer to page 4-87

Guidelines for 2WD to 4WD Switching

Drive type	2WD	4WD	
	2H	4H (4WD high)	4L (4WD low)
4WD switch			
Indicator light	OFF		
Models with MID*			
Driving conditions	During normal driving on an ordinary road or highway.	Wet roads, snow-covered roads, icy roads, and other roads where the vehicle needs more traction than 2WD.	Steep slopes, rough roads, sand, mud or deep snow, and other roads where the vehicle needs significant traction.

*: When the 4WD switch has been operated in each position, it will be displayed on the MID for approximately 3 seconds.



ADVICE

- Do not set the 4WD switch midway between the "2H" and "4H" positions or the "4H" and "4L" positions. Doing so could cause a malfunction.

Switching from "2H" to "4H (4WD High)"

WARNING

- Do not operate the 4WD switch from "2H" to "4H" while the wheels are spinning. Stop the slipping or spinning first, and then operate the 4WD switch.

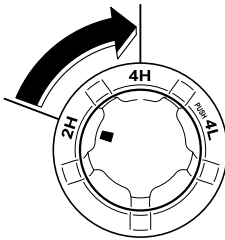

4WD indicator light

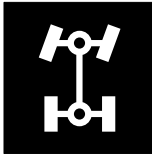

- Keep the vehicle moving straight and operate the 4WD switch to the "4H" position at a constant speed below 100 km/h (60 MPH).

NOTE

- When the 4WD switch is operated at vehicle speeds over 100 km/h (60 MPH), the 4WD indicator light flashes and a warning buzzer sounds.

- The 4WD indicator light comes on when "2H" is switched to "4H". The 4WD indicator light continues flashing until the operation is complete.

NOTE

- If the 4WD indicator light does not come on, move the vehicle slowly forward and backward.

Switching from "4H (4WD High)" to "2H"

- Keep the vehicle moving straight and operate the 4WD switch to the "2H" position at a constant speed below 100 km/h (60 MPH).

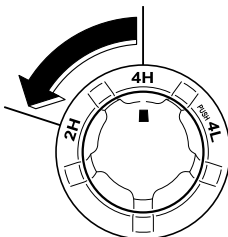

2. The 4WD indicator light goes off when "4H" is switched to "2H".
The 4WD indicator light continues flashing until the operation is complete.

**NOTE**

- If the 4WD indicator light does not go off, move the vehicle slowly forward and backward.

Switching between "4H (4WD High)" and "4L (4WD Low)"**NOTE**

- Operate the 4WD switch when all of the following conditions are fulfilled. If the 4WD switch is operated when the conditions are not fulfilled, a warning buzzer sounds while the 4WD indicator light and 4WD low indicator light flash (at about 1/2-second intervals) to inform the driver that switching to "4H" or "4L" is not possible.
 - The vehicle is stationary.
 - The engine speed is less than 2,000 r/min.
 - The clutch pedal is fully depressed, or the gearshift lever is placed in the "N" position (manual transmission model).
 - The selector lever is placed in the "N" position (automatic transmission model).
- If the status before the 4WD switch operation is any of the following, a waiting time is needed before switching to "4H" or "4L" can be performed (waiting time: A maximum of approximately 3 minutes).
The 4WD indicator light and 4WD low indicator light flash (at about 1/2-second intervals) until switching is complete.
In these cases, the waiting time can be reset by switching the power mode to "OFF" (models with passive entry and start system) or turning the starter switch to the "LOCK" position (models without passive entry and start system).
 - The vehicle is stopped for an extended period of time with the gearshift lever in the "1 (1st)" position and the clutch pedal depressed (manual transmission model).
 - The vehicle is stopped for an extended period of time with the selector lever in the "D" position and the brake pedal depressed (automatic transmission model).

1. Stop the vehicle.
2. On the manual transmission model, fully depress the clutch pedal or shift the gearshift lever to the "N" position. On the automatic transmission model, shift the selector lever to the "N" position and check that the shift indicator indicates "N".
3. Select "4H" or "4L" while pressing the 4WD switch.

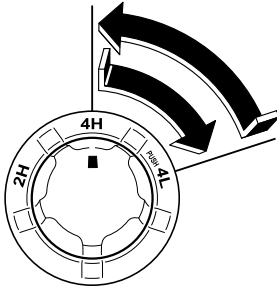

4WD low indicator light

4L

4. When "4H" is switched to "4L", the 4WD low indicator light comes on, and when "4L" is switched to "4H", the 4WD low indicator light goes off.



NOTE

- If the 4WD low indicator light does not come on or go off, move the vehicle slowly forward and backward.

Switching between "2H" and "4L (4WD Low)"**CAUTION**

- Do not operate the 4WD switch while the rear wheels are spinning on a snow-covered, frozen or slippery road.

**NOTE**

- Operate the 4WD switch when all of the following conditions are fulfilled. If the 4WD switch is operated when the conditions are not fulfilled, a warning buzzer sounds while the 4WD indicator light and 4WD low indicator light flash (at about 1/2-second intervals) to inform the driver that switching to "2H" or "4L" is not possible.
 - The vehicle is stationary.
 - The engine speed is less than 2,000 r/min.
 - The clutch pedal is fully depressed, or the gearshift lever is placed in the "N" position (manual transmission model).
 - The selector lever is placed in the "N" position (automatic transmission model).
- If the status before the 4WD switch operation is any of the following, a waiting time is needed before switching to "2H" or "4L" can be performed (waiting time: A maximum of approximately 3 minutes).

The 4WD indicator light and 4WD low indicator light flash (at about 1/2-second intervals) until switching is complete.

In these cases, the waiting time can be reset by switching the power mode to "OFF" (models with passive entry and start system) or turning the starter switch to the "LOCK" position (models without passive entry and start system).

 - The vehicle is stopped for an extended period of time with the gearshift lever in the "1 (1st)" position and the clutch pedal depressed (manual transmission model).
 - The vehicle is stopped for an extended period of time with the selector lever in the "D" position and the brake pedal depressed (automatic transmission model).

1. Stop the vehicle.
2. On the manual transmission model, fully depress the clutch pedal or shift the gearshift lever to the "N" position. On the automatic transmission model, shift the selector lever to the "N" position and check that the shift indicator indicates "N".
3. Operate the 4WD switch to "4L" or "2H".

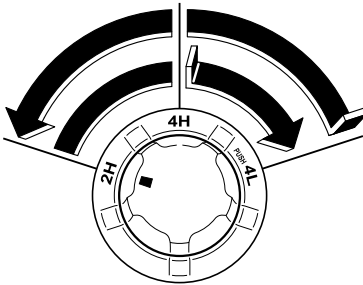

4WD indicator light

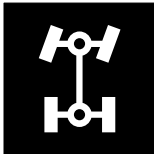

4WD low indicator light



4. When "2H" is switched to "4L", the 4WD indicator light and 4WD low indicator light come on, and when "4L" is switched to "2H", the 4WD indicator light and 4WD low indicator light go off.

**NOTE**

- If the 4WD indicator light and 4WD low indicator light do not come on or go off, move the vehicle slowly forward and backward.

Diesel Particulate Defuser (DPD)

The DPD purifies diesel exhaust gases of particulate matter (PM). PM is filtered from the exhaust gas and accumulated in the DPD. When PM accumulates to level predetermined by the engine control module, the DPD automatically burns the PM in a process called regeneration. Regeneration may not be completed under certain driving conditions. If this occurs, the DPD operator regeneration indicator light will flash to prompt for the completion of DPD regeneration.

Automatic Regeneration of DPD

The DPD will regenerate itself as part of normal operation. The engine control module controls this function based on several factors. During regeneration, the engine idle speed will increase. When this occurs, the DPD is automatically regenerated. This does not indicate a failure.



ADVICE

- The DPD performs regeneration automatically when a certain amount of PM accumulates in the DPD. Regeneration occurs during driving and the DPD operator regeneration indicator light does not come on during regeneration. Depending upon driving conditions, however, the regeneration may sometimes not be completed. In this case, the DPD operator regeneration indicator light will flash, so perform operator regeneration as soon as possible according to the "Operator Regeneration Procedure". This operation recovers the function of the DPD. It does not mean that a failure has occurred.



NOTE

- In models with an MID, the amount of PM accumulated in the DPD and the progress status for DPD regeneration can be displayed with the MID.
- Regeneration time may differ depending on outside temperature, engine coolant temperature and driving conditions.
- During regeneration, white smoke may be temporarily produced from the exhaust pipe. This results from combustion of PM, it does not indicate a failure.
- The engine coolant temperature may rise during regeneration.

NOTE (Continued)

NOTE (Continued)

- Automatic regeneration is performed under normal driving conditions, however, operator regeneration may be required under the following conditions.
 - If the vehicle is only driven at low speeds
 - If the engine is frequently started and stopped
 - If the engine frequently idles for extended periods (1 hour or more)
 - If the engine is habitually stopped before engine warming is complete

DPD PM Level → Refer to page 4-42

Progress of DPD Regeneration

→ Refer to page 4-43

Operator Regeneration of DPD

DPD operator regeneration indicator light

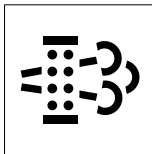

Steps for regenerating the DPD should be taken when the DPD operator regeneration indicator light flashes. Perform operator regeneration as soon as possible according to the "Operator Regeneration Procedure". If driving is continued with the light slowly flashing (1 Hz), the light will begin to flash more quickly (3 Hz). If driving is continued in this state for too long, the DPD may fail. Therefore, perform operator regeneration immediately according to the "Operator Regeneration Procedure".



ADVICE

- If the status of DPD regeneration continues to be incomplete, the malfunction indicator light (MIL) will come on. If this occurs, have your vehicle inspected/ serviced at your Isuzu Dealer as soon as possible.



NOTE

- Depending on usage conditions, the light may begin flashing quickly (3Hz). If this occurs, perform operator regeneration immediately according to the "Operator Regeneration Procedure".

Operator Regeneration Procedure

1. Drive at a constant speed more than 70 km/h (45 MPH) while paying attention to the vehicle surroundings.
2. When vehicle speed, engine coolant temperatures and other factors are met, the DPD operator regeneration indicator light will switch from intermittent flashing to continuous illumination and DPD regeneration will begin.
3. Drive at as constant of a speed as possible. Operator regeneration of DPD is complete once the DPD operator regeneration indicator light will go off.



WARNING

- It is not always necessary to continue driving under the conditions mentioned above. Always drive safely in accordance with road and traffic conditions.



ADVICE

- Although operator regeneration of DPD is usually completed within approximately 15 minutes, the time may differ depending on outside temperature, engine coolant temperature and driving conditions. As a guide, for completing operator regeneration in cold regions, continue driving in 4th gear (for automatic transmission models, maintaining 4th gear in manual mode) at more than 70 km/h (45 MPH) for approximately 15 minutes.



NOTE

- During regeneration, the engine idle speed will increase.
- In models with an MID, the amount of PM accumulated in the DPD and the progress status for DPD regeneration can be displayed with the MID.
- DPD regeneration process will continue even in the case of deceleration or vehicle stoppage. In addition, it is possible to turn off the engine during the process. In this case, the regeneration will stop, but the next time the engine coolant becomes warm after being started, the DPD operator regeneration indicator light will flash to prompt for the completion of DPD regeneration. If this occurs, perform operator regeneration as soon as possible according to the "Operator Regeneration Procedure".

Automatic Transmission Model

→ Refer to page 4-141

DPD PM Level → Refer to page 4-42

Progress of DPD Regeneration

→ Refer to page 4-43

COMFORT AND CONVENIENCE

5

• Air Outlets	5-2	• Small Article Storage Pocket (Upper Side of Dashboard)	5-41
• Automatic Air Conditioner	5-4	• Small Article Storage Pocket (Driver's Side)	5-42
• Heater/Manual Air Conditioner	5-15	• Center Console Box	5-43
• Interior Lights	5-26	• Cup Holder	5-44
• Overhead Console	5-30	• Cup Holder and Small Article Storage Pocket	5-45
• Sun Visor	5-31	• Bottle Holder and Small Article Storage Pocket (Front and Rear Doors)	5-47
• Ticket Holder	5-31	• Grip	5-47
• Vanity Mirror	5-32	• Coat Hook	5-48
• Cigarette Lighter	5-32	• Antenna	5-49
• Accessory Socket	5-34	• Steering Wheel Remote Control	5-51
• USB Power Outlet	5-35	• Rear Vision Camera	5-52
• Ashtray	5-37		
• Small Article Storage Pocket	5-38		
• Small Article Storage Pocket (Passenger's Side)	5-39		
• Glove Compartment	5-40		
• Dashboard Tray	5-41		

Air Outlets

Front outlets

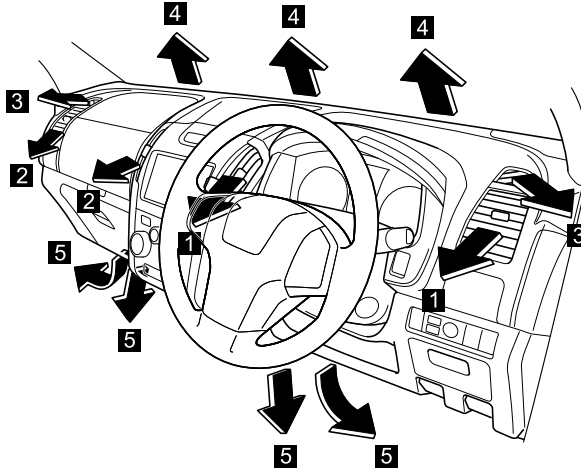

Rear seat outlets

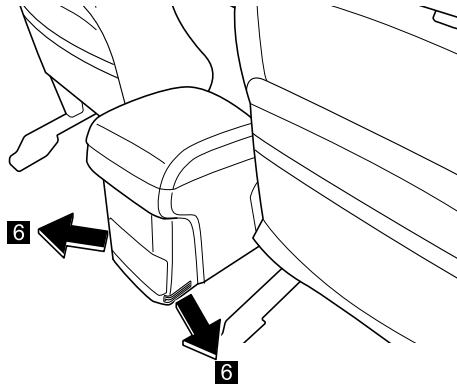

No.	Outlet	Features
1	Driver side outlet	Air flow direction is adjustable with the tab.
2	Passenger side outlet	Air flow direction is adjustable with the tab.
3	Door windows outlet	Air is delivered towards the door windows.
4	Windshield outlet	Air is delivered towards the windshield.
5	Foot outlet	Air is delivered towards the feet.
6	Rear seat outlet (If equipped)	Air is delivered towards the rear seat.

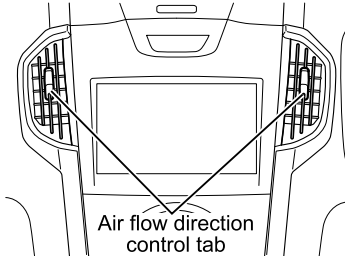
Air Flow Direction Control Tab**Front center outlet**

Use the tab to control the air flow direction from the outlet. To close the outlet, move the tab fully down.

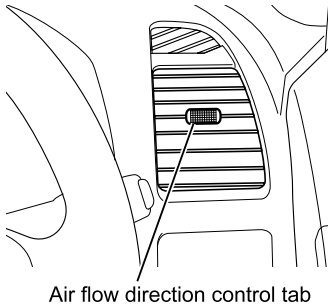
Front side outlet

5-4

COMFORT AND CONVENIENCE

Automatic Air Conditioner

Use the automatic air conditioner only when the engine is running.



ADVICE

- Do not use the automatic air conditioner when the engine is not running. The automatic air conditioner consumes large amounts of electricity and could discharge the battery completely.



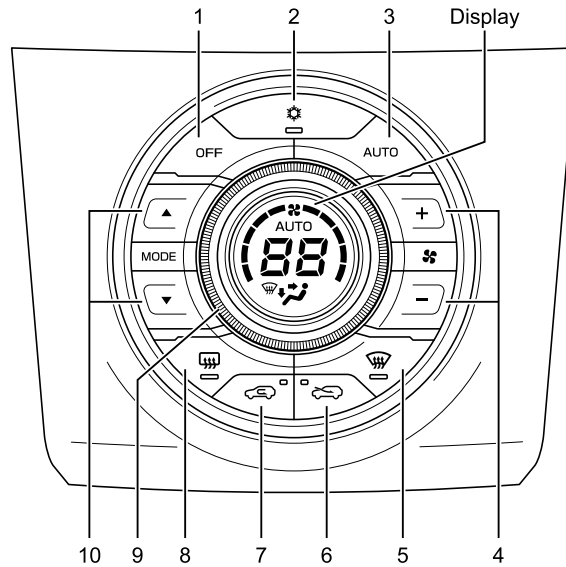

How to Use the Controls



No.	Name
1	Automatic air conditioning off switch (OFF switch)
2	Air conditioning switch (A/C switch)
3	Automatic air conditioning switch (AUTO switch)
4	Fan speed control switch

No.	Name
5	Windshield defroster switch
6	Outside air ventilation switch
7	Inside air recirculation switch
8	Rear window defogger switch
9	Temperature control dial
10	Outlet selector switch (MODE switch)

1. Automatic air conditioning off switch (OFF switch)
Press this switch to stop both the fan and air conditioning system.
2. Air conditioning switch (A/C switch)
Press the A/C switch to use the air conditioning system while the fan is operating. The indicator light inside the switch will come on to show that the air conditioning system is in operation. The indicator light will go out when the air conditioning system is not operating. The air conditioning system can also be used for dehumidifying while the heater is being used.
To turn off the air conditioning system, press the A/C switch again. The indicator will go out and the air conditioning system will turn off.
3. Automatic air conditioning switch (AUTO switch)
Press the AUTO switch to use the air conditioning system in the fully automatic mode. When the switch is pressed, "AUTO" is shown in the display and the system automatically selects the most suitable air outlets, fan speed and all other air conditioning parameters.
4. Fan speed control switch
Use this switch when manually selecting the fan speed. Pressing "+" increases the fan speed and pressing "-" reduces the fan speed. The fan speed can be adjusted through 5 levels.

Fan speed	Minimum	Low	Medium	Fast	Maximum
Displayed symbol					

**NOTE**

- Even in seasons when the air conditioning system is not used, occasionally operate the system for a few minutes with the engine running at a low speed in order to keep the system's components lubricated.
- The air conditioning system is operated by pressing the fan speed control switch.

5. Windshield defroster switch

Use this switch for defogging or defrosting the windshield. Pressing the switch causes the display to show the "☀️" symbol and the indicator light inside the switch to come on. The air conditioning will turn on in this case. Pressing the switch again will return the display to the setting prior to "☀️".

Displayed symbol	Purpose	Outlet
	Defroster	Air flows through outlets 3 and 4.

6. Outside air ventilation switch

Pressing the outside air ventilation switch causes the indicator light inside the switch to come on, and the mode switches to the outside air ventilation. Use this mode to ventilate the interior of the cab.

7. Inside air recirculation switch

Pressing the inside air recirculation switch causes the indicator light inside the switch to come on, and the mode switches to the inside air recirculation. Use this mode to prevent dusty or otherwise polluted outside air from entering the cab (such as in a tunnel or in congested traffic).



NOTE

- Extended use of the inside air recirculation position can cause the windshield and windows to fog up easily, which leads to poor visibility.

8. Rear window defogger switch

Use this switch for defogging or defrosting the rear window glass. With the power mode in "ON" (models with passive entry and start system) or the starter switch in the "ON" position (models without passive entry and start system), press the rear window defogger switch to turn on the rear window defogger. The indicator light comes on. Press the switch again to turn it off. The indicator light will then go out.



ADVICE

- Do not use the rear window defogger while the engine is not running. The rear window defogger consumes a lot of electricity and could discharge the battery completely.
- Turn the switch off promptly after the rear window is defogged or defrosted.



NOTE





- Since the rear window defogger function consumes a lot of electricity, operation will automatically turn off after approximately 10 minutes of operation.
- In models with a mirror heater, press the rear window defogger switch to activate the mirror heater at the same time and defog the mirror surface.

9. Temperature control dial

Use the temperature control dial for setting the preferred interior temperature. The display will show the set temperature. Each turn of the dial by one notch changes the temperature by 1°C (1.8°F). The adjustable temperature range is between 18 °C (64°F) and 32°C (90°F). If you set the temperature at 18°C (64°F), the system invariably sets the control for maximum cooling; if you set it at 32°C (90°F), the system sets the control for maximum heating.

10. Outlet selector switch (MODE switch)

The air outlet will change each time you press the MODE switch ("▲" or "▼"). The outlet currently selected will be shown on the display.

Displayed symbol	Air delivery	Outlet
	Face	Air flows through outlets 1 and 2.
	Bi-level	Air flows through outlets 1, 2, 5 and 6 (if equipped).
	Feet	Air flows through outlet 5, 6 (if equipped), and a miniscule amount flows through outlets 3 and 4.
	Feet and defroster	Air flows through outlet 5, 6 (if equipped), and slightly through outlets 3 and 4.



NOTE

- When you set to the " " position, the air sent to the feet and legs is comparatively less than the air sent to the upper body.

Automatic Air Conditioning Mode

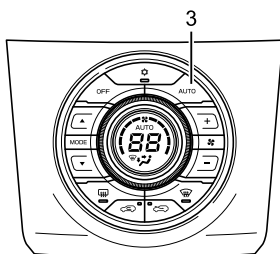

1. Press the AUTO switch (3). The air conditioning system will turn on, and automatically select the air outlets and fan speed most suitable for the condition of the interior of the cab. The display will then show "AUTO".

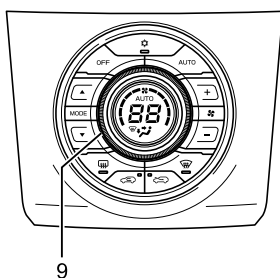

2. Use the temperature control dial (9) to set the interior temperature to the preferred level. The display will show the set temperature. Each turn of the dial by one notch changes the temperature by 1°C (1.8°F).



NOTE

- The number that is shown on the display shows an approximate set temperature. You may thus need finer adjustments for the preferred interior temperature.
- The adjustable temperature range is between 18°C (64°F) and 32°C (90°F). If you set the temperature at 18°C (64°F), the system invariably sets the control for maximum cooling; if you set it at 32°C (90°F), the system sets the control for maximum heating.
- Because the heater uses the heat from the engine coolant, its heating effect is weak when the engine coolant temperature is low.

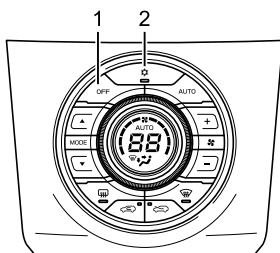

3. To turn off the air conditioning system, press the A/C switch (2). To turn off both the fan and air conditioning system, press the OFF switch (1).

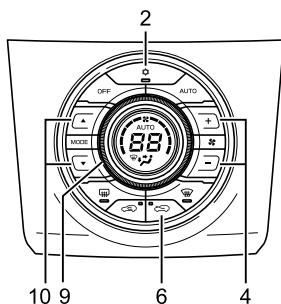
Manual Air Conditioning Mode**Outside Air Ventilation**

Press the A/C switch (2) to turn off the air conditioning system. The indicator light inside the switch will go out.

Select the preferred settings with the temperature control dial (9) and the MODE switch (10).

Press the outside air ventilation switch (6). The indicator light inside the switch will come on, and the mode switches to the outside air ventilation. Adjust the fan speed with the fan speed control switch (4) as necessary.

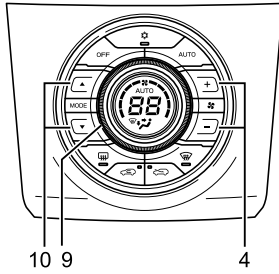

Maximum Heating

Turn the temperature control dial (9) to the maximum heating temperature (32°C (90°F)) and set the fan speed control switch (4) to the maximum speed setting by pressing "+". Select the preferred air outlets with the MODE switch (10).

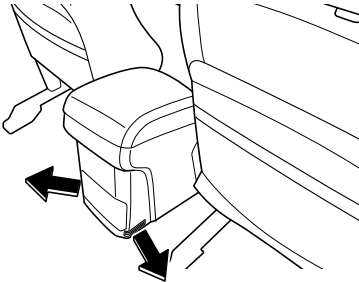
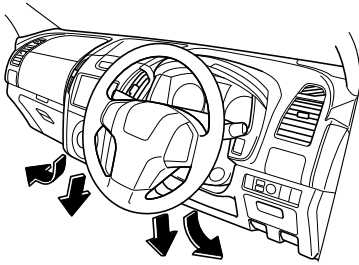

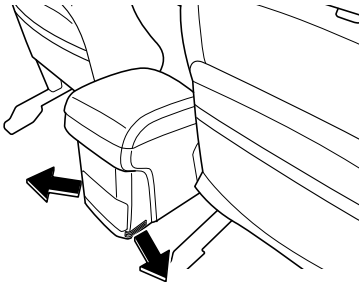
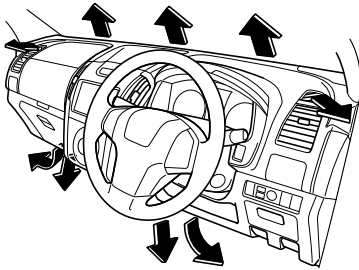
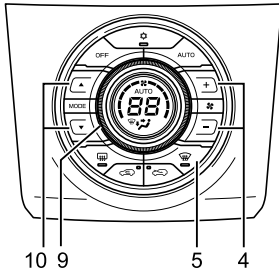

Defogging

Press the windshield defroster switch (5) to turn the defroster on. The display will show the "☀️" sign and the indicator light inside the switch will come on. The air conditioning system starts operating. Turn the temperature control dial (9) to the preferred setting.

Turn the fan speed control switch (4) to the preferred setting. The efficiency of defogging will be lower when "🔄" (inside air recirculation) is selected than when "🚗" (outside air ventilation) is selected. Press the MODE switch (10) to select the preferred air outlets. If you press the switch so that the "☀️" sign appears on the display, the windshield can be defogged while warming your feet as well.



NOTE

- Do not use the maximum cooling position when operating the air conditioning system with the windshield defroster switch (5) to turn the defroster on. The outside surface of the windshield and windows will fog up, which leads to poor frontal visibility.
- To defog quickly, set the temperature to a high temperature position with a high fan speed.

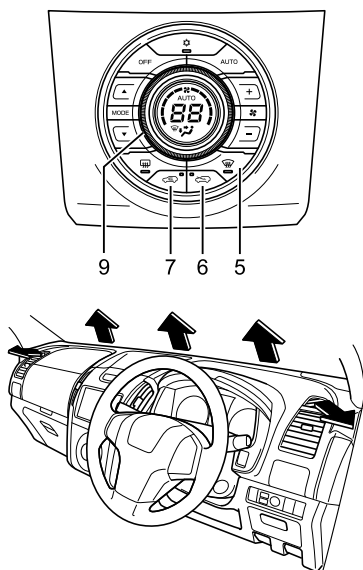

Defrosting

Press the windshield defroster switch (5) to turn the defroster on. The display will show the "☀️" sign and the indicator light inside the switch will come on. The air conditioning system starts operating. Turn the temperature control dial (9) to the maximum temperature position (32°C (90°F)).

Press the inside air recirculation switch (7). The indicator light inside the switch will come on, and the mode switches to the inside air recirculation.

⚠️ CAUTION

- After defrosting, make sure to press the outside air ventilation switch (6) so that it will be switched to the outside air ventilation. Failure to do so will cause the windshield and windows to fog up, which leads to poor frontal visibility.

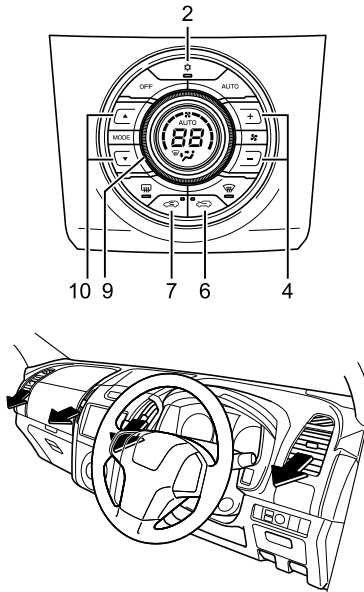

Maximum Cooling

Turn the temperature control dial (9) to the maximum cooling position (18°C (64°F)) and turn the fan speed control switch (4) to the maximum speed setting by pressing "+". Select the preferred air outlets with the MODE switch (10) and press the inside air recirculation switch (7). The indicator light inside the switch will come on, and the mode switches to the inside air recirculation.

You must press the A/C switch (2) before doing the above operation to turn the air conditioning system on.



NOTE

- After prolonged parking in direct sunlight, open the windows or doors to ventilate the interior of the cab and release the heat before turning the air conditioning system on.
- Prolonged use of the air conditioning system in the maximum cooling setting will make the interior air become stale. Occasionally press the outside air ventilation switch (6) to change to the outside air introduction mode or open the windows to allow fresh air into the cab.
- During the cooling operation, mist may come out of the air outlets. This results from sudden cooling of humid air, and it does not indicate any problem.

Temperature Sensors

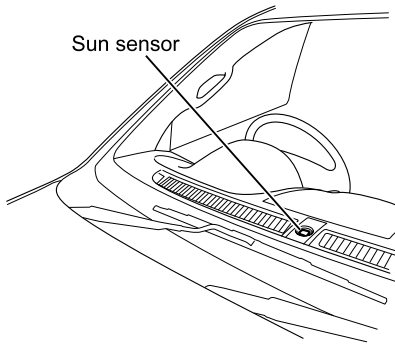

The air conditioning system uses a sun sensor, interior temperature sensor and outside air temperature sensor to ensure effective and comfortable air conditioning. Do not place anything on the sensors or get them wet. Air conditioning control will become inaccurate.

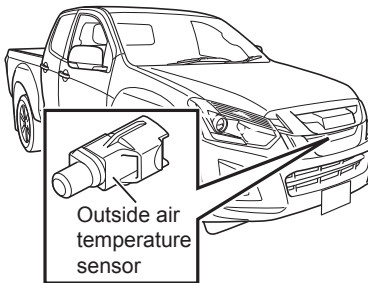
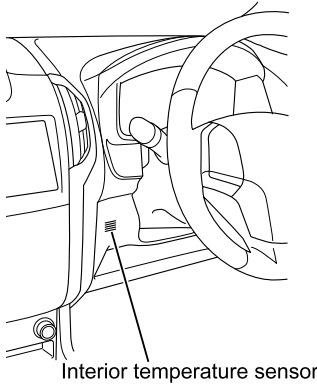

Heater/Manual Air Conditioner

Use the heater and manual air conditioner only when the engine is running.



ADVICE

- Do not use the heater or manual air conditioner when the engine is not running. The heater and manual air conditioner consume a lot of electricity and could discharge the battery completely.

How to Use the Controls

Models with heater (without cooler)

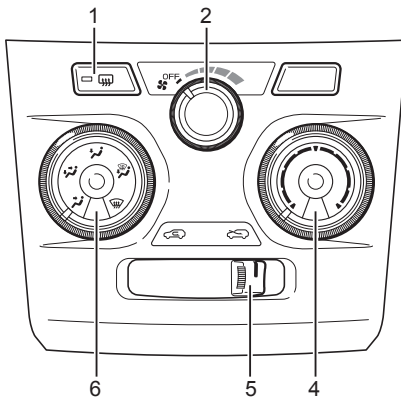

Models with air conditioner (cooler and heater)

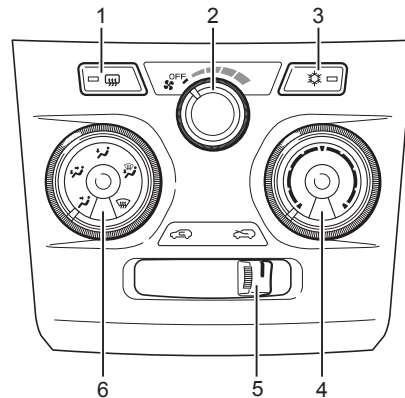

No.	Name
1	Rear window defogger switch (if equipped)
2	Fan speed control dial
3	Air conditioning switch (A/C switch)

No.	Name
4	Temperature control dial
5	Air selector lever
6	Outlet selector dial

1. Rear window defogger switch (if equipped)

Use this switch for defogging or defrosting the rear window glass. With the power mode in "ON" (models with passive entry and start system) or the starter switch in the "ON" position (models without passive entry and start system), press the rear window defogger switch to turn on the rear window defogger. The indicator light comes on. Press the switch again to turn it off. The indicator light will then go out.



ADVICE

- Do not use the rear window defogger while the engine is not running. The rear window defogger consumes a lot of electricity and could discharge the battery completely.
- Turn the switch off promptly after the rear window is defogged or defrosted.



NOTE

- Since the rear window defogger function consumes a lot of electricity, operation will automatically turn off after approximately 10 minutes of operation.
- In models with a mirror heater, press the rear window defogger switch to activate the mirror heater at the same time and defog the mirror surface.

2. Fan speed control dial

The fan speed can be adjusted to any of the 4 speeds that are available. To stop the air flow, return the fan speed control dial to the "OFF" position.

3. Air conditioning switch (A/C switch)

In models with an air conditioner (cooler and heater), press the A/C switch to use the air conditioning system. The indicator light inside the switch will come on to show that the air conditioning system is in operation. The indicator light will go out when the air conditioning system is not operating. The air conditioning system can also be used for dehumidifying while the heater is being used.





NOTE

- Even if the A/C switch is turned on, the air conditioning system will not operate when the fan speed control dial is placed in the "OFF" position. Make sure that the fan speed control dial is in a position other than the "OFF" position.
- In models with an air conditioner, even in seasons when the air conditioning system is not used, occasionally operate the system for a few minutes with the engine running at a low speed in order to keep the system's components lubricated.

4. Temperature control dial

The interior temperature can be set as necessary. The outlet temperature will be low when the temperature control dial is set to the leftmost position, and the outlet temperature will be high when the dial is set to the rightmost position.





5. Air selector lever

Lever position	Purpose	
	Outside air ventilation	Use this position to ventilate the interior of the cab.
	Inside air recirculation	Use this position to prevent dusty or otherwise polluted outside air from entering the cab (such as in a tunnel or in congested traffic).

**NOTE**

- Extended use of the inside air recirculation position can cause the windshield and windows to fog up easily, which leads to poor visibility.

6. Outlet selector dial

Dial position	Air delivery	Outlet
	Face	Air flows through outlets 1 and 2.
	Bi-level	Air flows through outlets 1, 2, 5 and 6 (if equipped).
	Feet	Air flows through outlet 5 and 6 (if equipped).
	Feet and defroster	Air flows through outlet 5, 6 (if equipped), and slightly through outlets 3 and 4.
	Defroster	Air flows through outlets 3 and 4.

**NOTE**

- When you set to the "

Ventilation

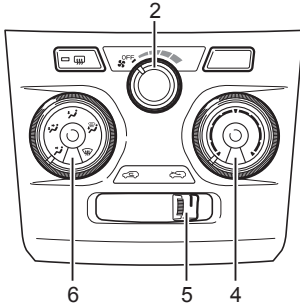
**Outside Air Ventilation (models with heater (without cooler))**

Turn the outlet selector dial (6) to the preferred position. Move the air selector lever (5) to the "↔" position. Set the temperature control dial (4) to the preferred position depending on the season and climate.

Adjust the fan speed control dial (2) to the preferred speed.

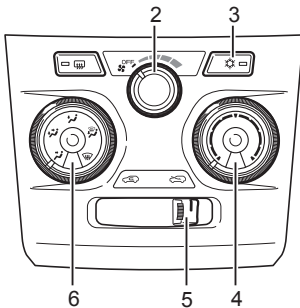
**Outside Air Ventilation (models with air conditioner (cooler and heater))**

Press the A/C switch (3) to turn it off. Turn the outlet selector dial (6) to the preferred position. Move the air selector lever (5) to the "↔" position. Set the temperature control dial (4) to the preferred position depending on the season and climate.

Adjust the fan speed control dial (2) to the preferred speed.

How to Use the Heater

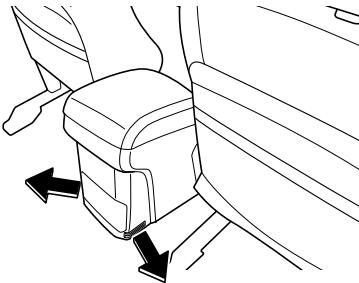
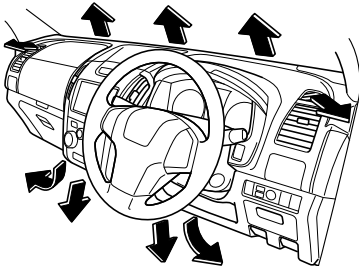
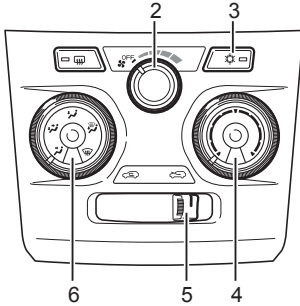
**Normal Heating**

Set the outlet selector dial (6) to the "feet" or "windshield" position. Use the "windshield" position for warming your feet while defogging the windshield. Set the air selector lever (5) to the "face" position. Adjust the temperature control dial (4) and the fan speed control dial (2) to the preferred positions.

If your vehicle is equipped with an air conditioning system, to dehumidify the cab interior while heating, press the A/C switch (3) to turn it on.

**NOTE**

- Because the heater uses the heat from the engine coolant, its heating effect is weak when the engine coolant temperature is low.

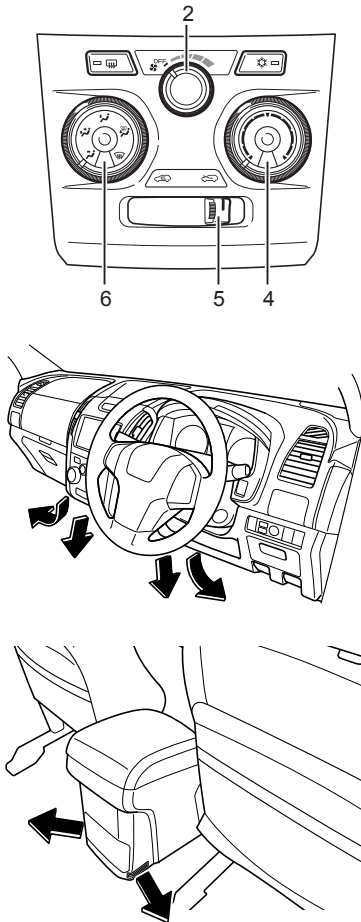

Maximum Heating

Turn the outlet selector dial (6) to the "↖" position, set the air selector lever (5) to the "↖" position, and turn the temperature control dial (4) fully towards the rightmost direction (high temperature direction). Set the fan speed control dial (2) to the maximum speed position.



NOTE

- Extended use of the inside air recirculation position can cause the windshield and windows to fog up easily, which leads to poor visibility.

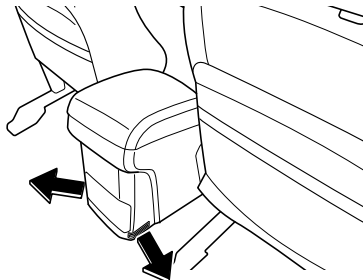
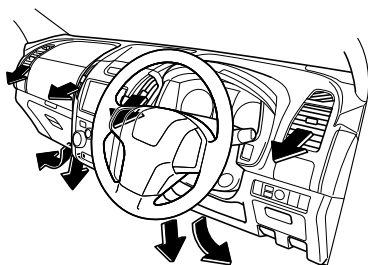
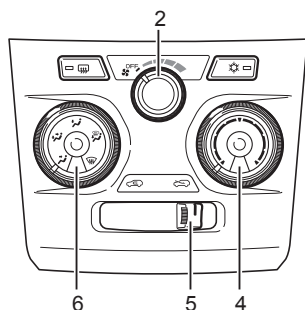

Bi-level Heating

Set the outlet selector dial (6) to the "☺" position.

Set the air selector lever (5) to the "☺" position.

Set the temperature control dial (4) to the middle position.

Adjust the fan speed control dial (2) as necessary.



NOTE

- When you set to the "☺" position, the air sent to the feet and legs is comparatively warmer than the air sent to the upper body.

Defogging and Defrosting the Windshield

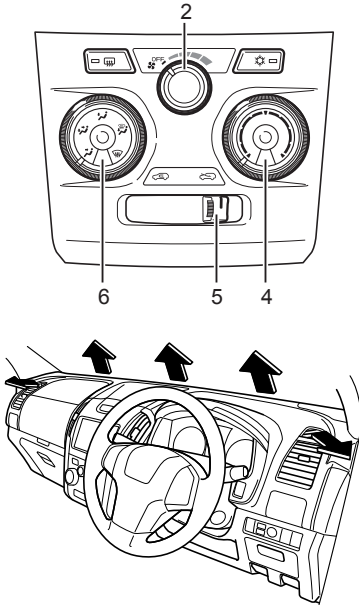

Defogging

Set the outlet selector dial (6) to the "☼" position.

Set the air selector lever (5) to the "☼" position.

Turn the temperature control dial (4) to a right side position (high-temperature position) according to your preference.

For defogging in the summer, set the temperature control dial (4) to any preferred position.

Adjust the fan speed control dial (2) as necessary.

If your vehicle is equipped with an air conditioning system, using the dehumidifying effect of the system is very effective for defogging.



NOTE

- Do not use the maximum cooling position when operating the air conditioning system with the outlet selector dial (6) set to the "☼" position. The outside surface of the windshield and windows will fog up, which leads to poor frontal visibility.

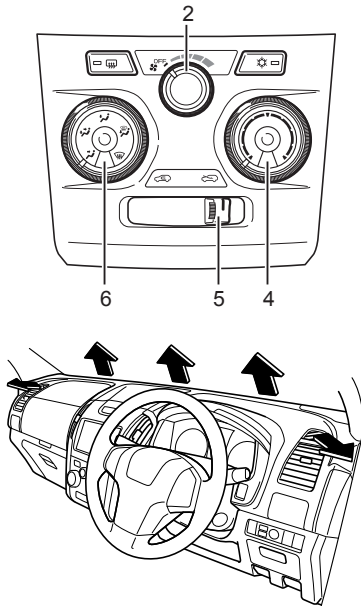

Defrosting

Set the outlet selector dial (6) to the "WINDSHIELD" position.

Set the air selector lever (5) to the "DEFROST" position.

Turn the temperature control dial (4) fully towards the rightmost direction (high-temperature direction).

Set the fan speed control dial (2) to the maximum speed position.



NOTE

- After defrosting, be certain to return the air selector lever (5) to the "DEFROST" position. Failure to do so will cause the windshield and windows to fog up, which leads to poor frontal visibility.

Cooling (Models with Air Conditioner)

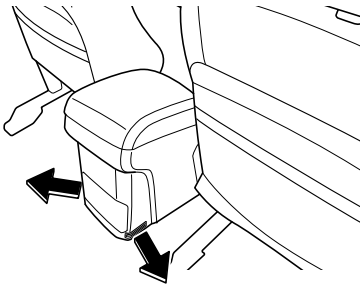
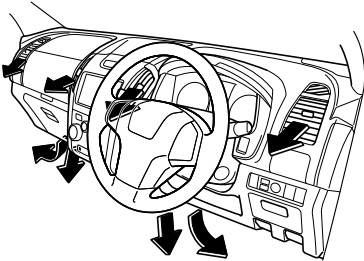
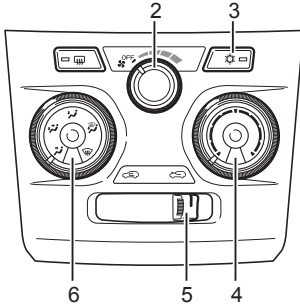
**Normal/Moderate Cooling**

This setting is suitable for extended periods of cooling or moderate cooling.

Press the A/C switch (3) to turn it on.

Set the outlet selector dial (6) to the "↖↗" position for normal cooling (or set it to the

"↖↗" position for moderate cooling).

Adjust the temperature control dial (4) to the preferred position depending on the season and climate.

Adjust the fan speed control dial (2) as necessary.

**NOTE**

- When using the air conditioning system with the engine idling in extremely hot weather, place the air selector lever (5) in the "↖↗" position.

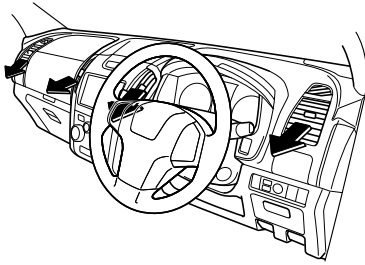
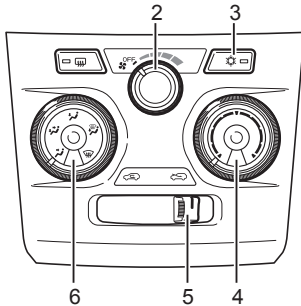

Maximum Cooling

Set the outlet selector dial (6) to the "↗" position.

Press the A/C switch (3) to turn it on.

Move the air selector lever (5) to the "↗" position.

Turn the temperature control dial (4) fully towards the leftmost direction (low-temperature direction).

Set the fan speed control dial (2) to the maximum speed position.



NOTE

- After prolonged parking in direct sunlight, open the windows or doors to ventilate the interior of the cab and release the heat before turning the air conditioning system on.
- Prolonged use of the air conditioning system in the maximum cooling setting will make the interior air become stale. Occasionally move the air selector lever (5) to the outside air introduction position or open the windows to allow fresh air into the cab.
- During the cooling operation, mist may come out of the air outlets. This results from sudden cooling of humid air, and it does not indicate any problem.

Interior Lights

Dome Light

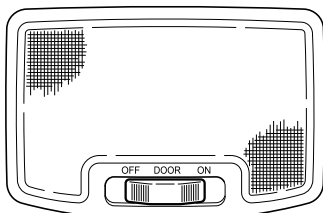

The dome light operates regardless of the power mode (models with passive entry and start system) or starter switch position (models without passive entry and start system).

ON:

The light stays on regardless of the doors being open or closed.

**NOTE**

- In models with a passive entry and start system or keyless entry system (radio remote control units for door-lock), the light will automatically turn off after approximately 20 minutes to prevent battery discharge when all doors are securely closed, the power mode is a mode other than "ON" (models with passive entry and start system) or the starter switch is in a position other than "ON" (models with keyless entry system), and the light switch is in the "ON" position.
- In models with a passive entry and start system or keyless entry system (radio remote control units for door-lock), the light turns off in a different manner when the doors are locked depending on its switch position ("ON" or "DOOR").

DOOR:

The light turns on when a door is opened and turns off when the door is closed. In addition, in models with a passive entry and start system or a keyless entry system (radio remote control units for door-lock), the light also turns on and off under the following conditions.

- When the power mode is switched to "OFF" (models with passive entry and start system) or the starter switch is turned to a position other than "ON" (models with keyless entry system) and a door is open, closing the door will turn the light on for approximately 30 seconds, after which it will turn off automatically.
- When the power mode is switched to "ON" or "ACC" (models with passive entry and start system) or the starter switch is turned to the "ON" position (models with keyless entry system), opening and then closing a door will turn the light off.
- When the doors are closed, switching the power mode to "OFF" (models with passive entry and start system) or removing the key from the starter switch (models with keyless entry system) will turn the light on for approximately 30 seconds, after which it will then turn off automatically.
- When the doors are closed, switching the power mode to "ON" or "ACC" (models with passive entry and start system) or turning the starter switch to the "ON" position (models with keyless entry system) will turn off the light.

OFF:

The light stays off regardless of the doors being open or closed.

Map Lights

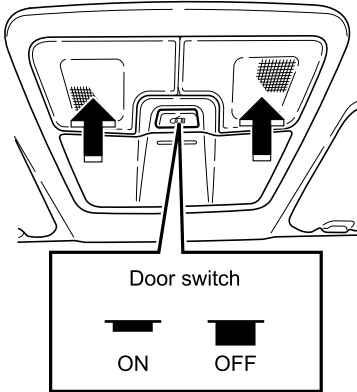

Type 1

When the map light is pushed, the map light on the pushed side will come on. If it is pushed again, it will turn off.

When the door switch is "ON", they will come on in conjunction with opening/closing of the doors.

In addition, in models with a passive entry and start system or a keyless entry system (radio remote control units for door-lock), the light also turns on and off under the following conditions.

- When the power mode is switched to "OFF" (models with passive entry and start system) or the starter switch is turned to a position other than "ON" (models with keyless entry system) and a door is open, closing the door will turn the light on for approximately 30 seconds, after which it will turn off automatically.
- When the power mode is switched to "ON" or "ACC" (models with passive entry and start system) or the starter switch is turned to the "ON" position (models with keyless entry system), opening and then closing a door will turn the light off.
- When the doors are closed, switching the power mode to "OFF" (models with passive entry and start system) or removing the key from the starter switch (models with keyless entry system) will turn the light on for approximately 30 seconds, after which it will turn off automatically.
- When the doors are closed, switching the power mode to "ON" or "ACC" (models with passive entry and start system) or turning the starter switch to the "ON" position (models with keyless entry system) will turn off the light.

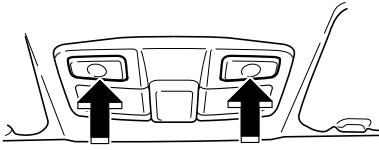
**Type 2**

When the map light switch is pushed, the map light on the side the switch is pushed will come on. If the map light switch is pushed again, it will turn off.

Overhead Console

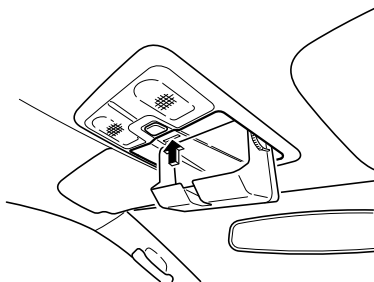

Use them for storing small articles.
Press the indented portion of the overhead console to open it.

WARNING

- For safety, close the overhead console lid during driving as there is a risk of injury from the open lid or from objects stored in the overhead console.
- Do not place heavy objects inside the overhead console. It is designed for storing light articles such as eyeglasses. The lid may open and objects may fall out, resulting in an accident.

CAUTION

- Do not leave eyeglasses or lighters inside the cab. Lighters may explode and plastic lenses or frames may deform or crack if the interior temperature becomes very hot.

Sun Visor

Driver's side

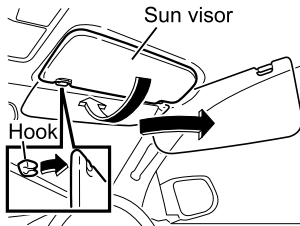

The sun visor protects your eyes in strong sunlight. Use it when sunlight is too bright. To reduce side glare, unhook the sun visor and swing it around to the side.

CAUTION

- For safety, make sure to fold up the sun visor after use.

Passenger's side

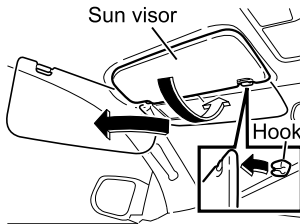

Ticket Holder

Driver's side

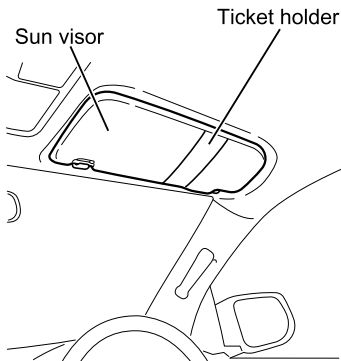

Use this to hold your tickets.

Vanity Mirror

Passenger's side

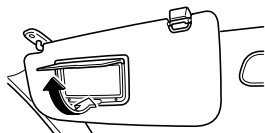

The vanity mirror is on the rear side of the front passenger's sun visor.

Cigarette Lighter

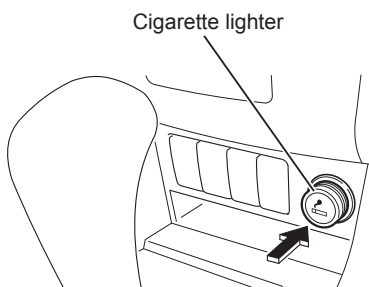

The cigarette lighter can be used when the power mode is "ACC" or "ON" (models with passive entry and start system) or the starter switch is in the "ACC" or "ON" position (models without passive entry and start system).

1. Push the lighter in until it locks.
2. When the heater element becomes hot, the lighter pops out to the original position. Pull out and use it.

**WARNING**

- As the lighter's tip can become extremely hot, take due precautions against burns.
- Do not leave your finger on the cigarette lighter once it has been pushed in. The lighter will overheat and be damaged or cause a fire.
- If the cigarette lighter does not pop out after more than 25 seconds, the lighter is defective. Pull out the lighter by hand immediately.
- Do not leave the vehicle with the cigarette lighter pushed in. This could cause a fire.
- As there is a burn hazard, do not touch the heater element when using the cigarette lighter.
- Do not bend the cigarette lighter. A bent lighter does not function properly and is dangerous.

**CAUTION**

- Check with your Isuzu Dealer if you have no alternative to using the cigarette lighter socket as an accessory outlet.
- If the cigarette lighter has to be replaced, use an Isuzu genuine replacement. Do not use other cigarette lighters.
- When cleaning the cigarette lighter, do not use too much force. It may become bent.
- Keep the cigarette lighter socket and the heater free of ash and dirt.

**ADVICE**

- Do not use the cigarette lighter while the engine is not running. The cigarette lighter consumes a lot of electricity and could discharge the battery completely.

Accessory Socket

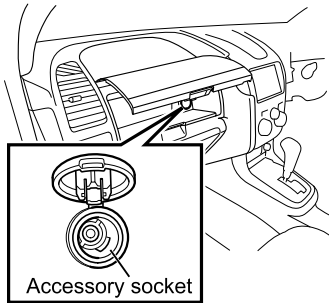

You can use this when the power mode is "ACC" or "ON" (models with passive entry and start system) or the starter switch is in the "ACC" or "ON" position (models without passive entry and start system).

Use it to supply power to commercially available vehicle accessories, etc. Open the cap to use. When using a commercially available electrical accessory, follow the instruction manual of the electrical accessory.

WARNING

- The maximum allowable load on the socket is 120 W (10 A). If you subject the socket to more than the allowable load, the wiring may overheat and cause a fire. Use the socket within the allowable load.
- The socket uses 12 V power. Connecting electrical accessories other than 12 V accessories could cause overheating and may result in a fire.
- Be sure to insert the plug of the electrical accessory all the way into the socket. Using an accessory when the plug is not completely inserted could cause abnormal heat generation and may result in the vehicle's fuses blowing.
- Do not insert the cigarette lighter into the socket. Doing so could generate heat.
- When not in use, be sure to attach the cap. If foreign matter enters the socket, or if water or drinks contact it, it could be damaged. Also, do not insert fingers or any metallic objects other than plugs into the socket.

ADVICE

- When not in use, turn off electrical accessories.
- Using the socket for a long period of time while the engine is stopped will deplete the battery.
- As the internal part of the socket may become deformed depending on the size of the plug used, do not attempt to force the plug into the socket. In this case, replace the socket.
- When inserting or removing the plug of an electrical accessory, turn the electrical accessory off, or switch the power mode to "OFF" (models with passive entry and start system) or place the starter switch in the "LOCK" position (models without passive entry and start system).

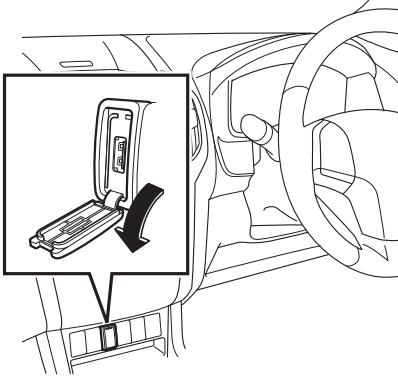
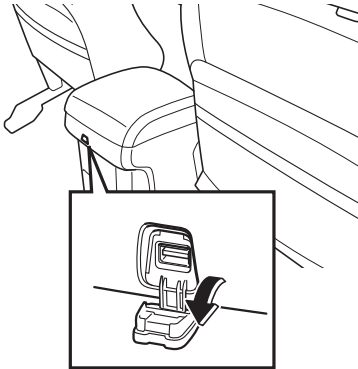
USB Power Outlet**Lower part of center instrument panel****Rear part of center console box**

The USB power outlet can be used when the power mode is "ACC" or "ON" (models with passive entry and start system) or the starter switch is in the "ACC" or "ON" position (models without passive entry and start system).

The power outlet is to be used for operating or charging compatible mobile devices or electronics. Refer to the owner's manuals of those products before using. Open the cap to use. Close the cap when not in use.

**CAUTION**

- Make sure that the connected USB cables, mobile devices, and electronics do not interfere with vehicle operation.

**ADVICE**

- A-Type USB terminals can be used with the power outlet. Do not attempt to insert other types of USB terminals.
- The maximum rating for each power outlet is 5.0 V/1.0 A. Before using, check that the equipment to be used is compatible by referring to its owner's manual, etc.
- It can only be used as a power output and not for transmitting data (including video and music data).
- After charging is complete, promptly disconnect all mobile devices and electronics.
- Do not connect USB hubs. Doing so could result in damage.
- Do not spill liquids on the power outlet, nor attempt to insert metals or other foreign objects. Doing so may result in an electric shock or damage.
- When using for extended periods with the engine stopped, take care as the battery may go flat.
- Do not connect damaged equipment or products.
- Damage to connected equipment or products, as well as any damage of or loss of data are not covered by warranty.
- When using USB cables, make sure that your legs do not get caught by the cables.

Ashtray

WARNING

- Do not put any paper trash or other flammable material in the ashtray.
- After using the ashtray, be sure to close it. If a cigarette butt has not been extinguished completely, other butts in the ashtray may catch fire.
- Do not leave the ashtray full of cigarette butts.
- Put matches and cigarette butts in the ashtray only after they are fully extinguished.
- Never throw lit cigarette butts out the window. They not only litter the road and around but also can cause a roadside fire.

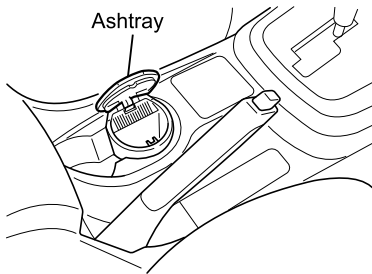

Open the lid to use.
Put out lit cigarettes on the crush-out tab.
Remove the ashtray to clean it.

Small Article Storage Pocket

Use them for storing small articles.

**CAUTION**

- Do not leave eyeglasses or lighters inside the cab. Lighters may explode and plastic lenses or frames may deform or crack if the interior temperature becomes very hot.
- Do not place lidless containers such as paper cups containing drinks in the center console small article storage pocket. Liquid in the container could be spilled inside the vehicle.

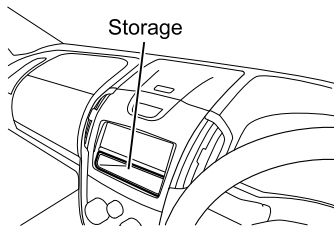
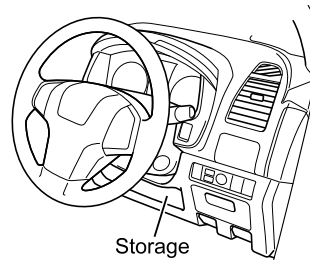
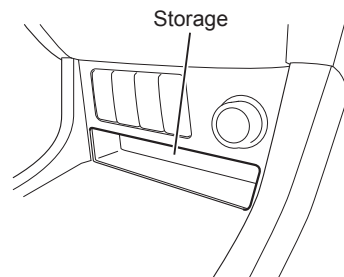
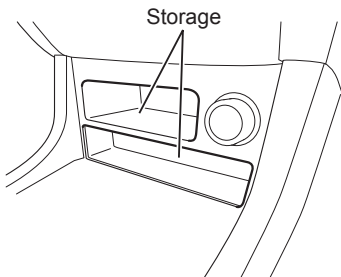
Center of instrument panel**Lower part of driver's side****Lower part of center of instrument panel**

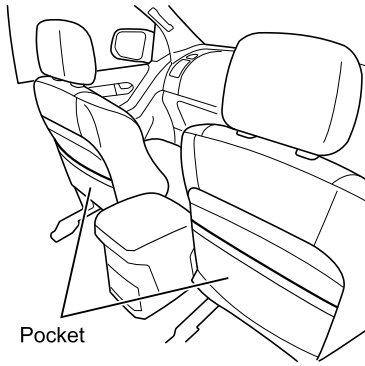
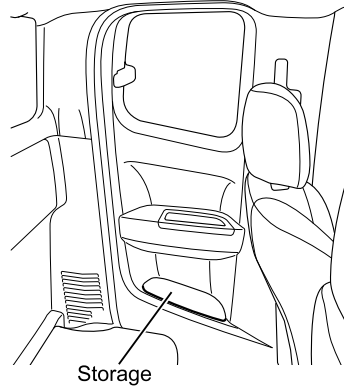
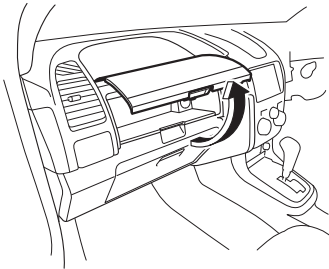
Front seatback**Side access panel (Extended cab model)****Small Article Storage Pocket (Passenger's Side)**

Pull up the cover to open.

**CAUTION**

- For safety, close the small article storage pocket (passenger's side) during driving. There is a risk of injury from the open lid or items stored in the small article storage pocket (passenger's side).
- Do not leave eyeglasses or lighters inside the cab. Lighters may explode and plastic lenses or frames may deform or crack if the interior temperature becomes very hot.

**ADVICE**

- Do not place an object in the small article storage pocket (passenger's side) that is so large that the lid of the compartment cannot be closed. If you attempt to close the lid in this condition, you are likely to break the lid of the small article storage pocket (passenger's side).

Glove Compartment

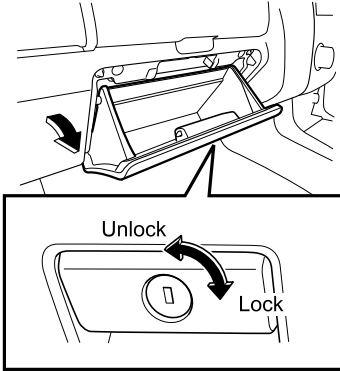

Pull the lever to open it.

Insert the key into the key lock and turn counterclockwise to unlock or clockwise to lock.



CAUTION

- For safety, close the glove compartment during driving. There is a risk of injury from the open lid or items stored in the glove compartment.
- Do not leave eyeglasses or lighters inside the cab. Lighters may explode and plastic lenses or frames may deform or crack if the interior temperature becomes very hot.



ADVICE

- Do not place an object in the glove compartment that is so large that the lid of the compartment cannot be closed. If you attempt to close the lid in this condition, you are likely to break the lid of the glove compartment.

Dashboard Tray

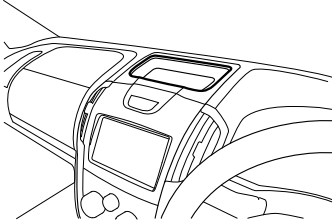

Use it for storing small articles.



CAUTION

- Do not leave eyeglasses or lighters inside the cab. Lighters may explode and plastic lenses or frames may deform or crack if the interior temperature becomes very hot.

Small Article Storage Pocket (Upper Side of Dashboard)

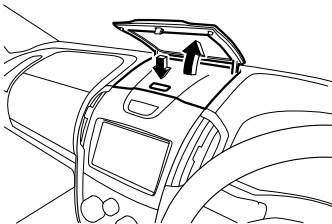

Press the button to open the lid.



CAUTION

- For safety, close the small article storage pocket (upper side of dashboard) during driving. There is a risk of injury from the open lid or items stored in the small article storage pocket (upper side of dashboard).
- Do not leave eyeglasses or lighters inside the cab. Lighters may explode and plastic lenses or frames may deform or crack if the interior temperature becomes very hot.



ADVICE

- Do not place an object in the small article storage pocket (upper side of dashboard) that is so large that the lid of the compartment cannot be closed. If you attempt to close the lid in this condition, you are likely to break the lid of the small article storage pocket (upper side of dashboard).

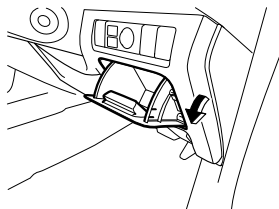
Small Article Storage Pocket (Driver's Side)

Pull towards you to open.

CAUTION

- For safety, close the small article storage pocket (driver's side) during driving. There is a risk of injury from the open lid or items stored in the small article storage pocket (driver's side).
- Do not leave eyeglasses or lighters inside the cab. Lighters may explode and plastic lenses or frames may deform or crack if the interior temperature becomes very hot.

**ADVICE**

- Do not place an object in the small article storage pocket (driver's side) that is so large that the lid of the compartment cannot be closed. If you attempt to close the lid in this condition, you are likely to break the lid of the small article storage pocket (driver's side).

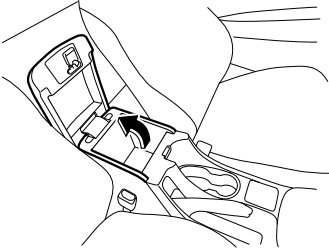
Center Console Box

Pull up the lid to open.

CAUTION

- For safety, close the center console box during driving. There is a risk of injury from the open lid or items stored in the center console box.
- Do not leave eyeglasses or lighters inside the cab. Lighters may explode and plastic lenses or frames may deform or crack if the interior temperature becomes very hot.

**ADVICE**

- Do not place an object in the center console box that is so large that the lid of the compartment cannot be closed. If you attempt to close the lid in this condition, you are likely to break the lid of the center console box.

Cup Holder



CAUTION

- Do not place objects in the cup holder if they have an improper size or shape. Sudden braking or pulling away could cause the object to fly out of the cup holder, leading to an injury.
- Do not place a cup that is too full in the cup holder. Spillages could cause damage to the other electrical circuits. If there is a spill, wipe it up immediately with a dry cloth.

Front Side

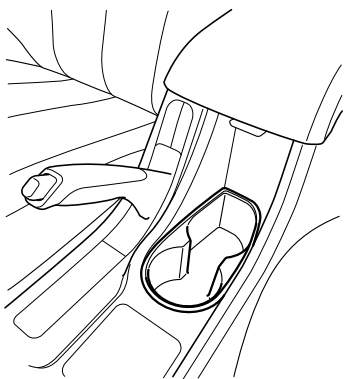

This can be used as a cup holder.



CAUTION

- Placing a water bottle in the cup holder could interfere with driving, leading to an accident.

Rear Side

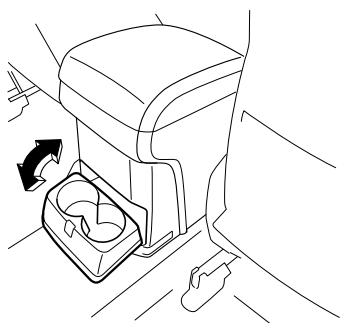

Pull towards you to open.

Cup Holder and Small Article Storage Pocket



WARNING

- Do not use the small article storage pocket as an ashtray or place any ashtrays inside. Doing so is dangerous and could lead to a fire in the vehicle.



CAUTION

- Do not place objects in the cup holder if they have an improper size or shape. Sudden braking or pulling away could cause the object to fly out of the cup holder, leading to an injury.
- Placing a water bottle could obscure the driver's view and interfere with driving, and this could lead to an accident.
- Do not place a cup that is too full in the cup holder. Spillages could cause damage to the radio and other electrical circuits. If there is a spill, wipe it up immediately with a dry cloth.
- There may be a danger of the cup holder and small article storage pocket breaking if the weight on it exceeds 0.75 kg (26 oz).

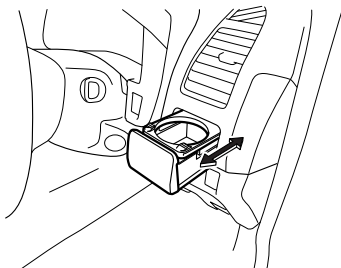
Driver's side

1. Pull towards you to open.

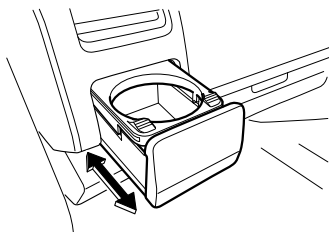
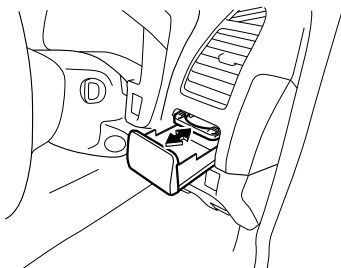
Passenger's side**Driver's side**

2. If only the cup holder is returned to its original position it can be used as the small article storage pocket.

3. If it is used as a cup holder before being returned to its original position, it will be a cup holder when it is opened again.

If it is used as a small article storage pocket before being returned to its original position, it will be a small article storage pocket when it is opened again.

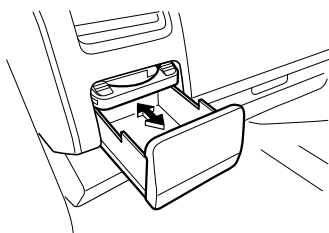
Passenger's side

Bottle Holder and Small Article Storage Pocket (Front and Rear Doors)

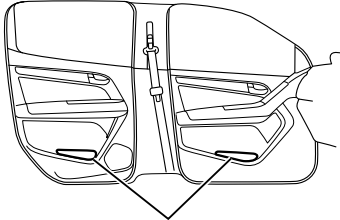

Bottle holder and small article storage pocket

Use as a bottle holder and small article storage pocket.



CAUTION

- Do not place lidless containers such as paper cups containing drinks in the bottle holder and small article storage pocket. Liquid in the container could be spilled inside the vehicle.

Grip

Folding type

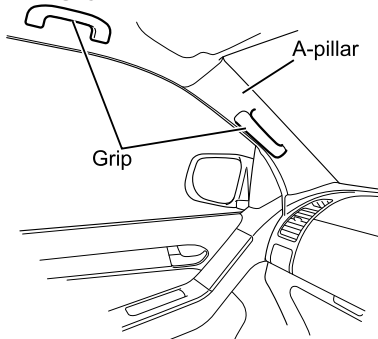

Fixed type

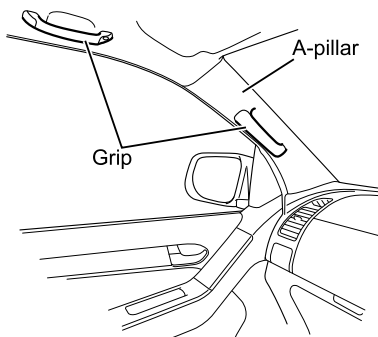

There are grips near the top of the windows.

A-pillar grips are equipped on 2WD High-Ride and 4WD models.



WARNING

- In models with side airbag and curtain airbag, if hard objects such as hangers or accessories are attached to the grip or coat hook, they may prevent normal operation of the curtain airbag and could fly off in the event of system activation.

Coat Hook

Crew cab model (type 1)

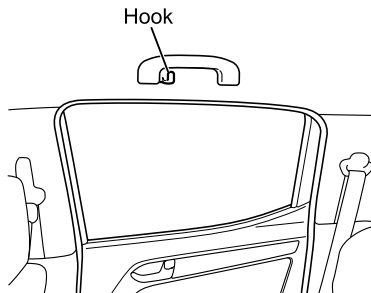

Crew cab model (type 2)

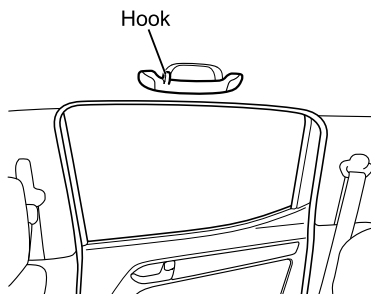

Extended cab model

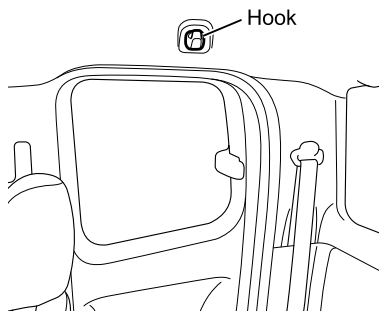

Use this to hang clothing.

WARNING

- To prevent hook cracking or breakage, do not hang heavy or large objects in the coat hook.
- In models with side airbag and curtain airbag, if hard objects such as hangers or accessories are attached to the grip or coat hook, they may prevent normal operation of the curtain airbag and could fly off in the event of system activation.

Antenna



NOTE

[Radio reception]

- Compared with AM signals, FM signals are of better quality and compatible with stereo broadcasting. However, due to the nature of FM signals, conditions in which the quality of signals received in a moving vehicle may not be sustainable.
 - The directness of FM signal transmission
As FM signals are more strongly directional than AM signals, they are blocked easily by large objects such as mountains and buildings and as such their reception area is much narrower than AM signals.
 - Sound loss
FM signals are reflected easily by objects, so when driving through built-up areas, the sound may be interrupted or disturbed by noise.
 - Sound distortion
Simultaneous reception of direct signals from the radio station and reflected signals from buildings may cause flutter or noise disturbance.

Shark Fin Type

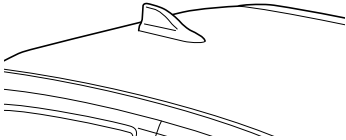

NOTE

- Radio reception may be affected by accessories or roof racks, etc., placed near the antenna.

Center Type

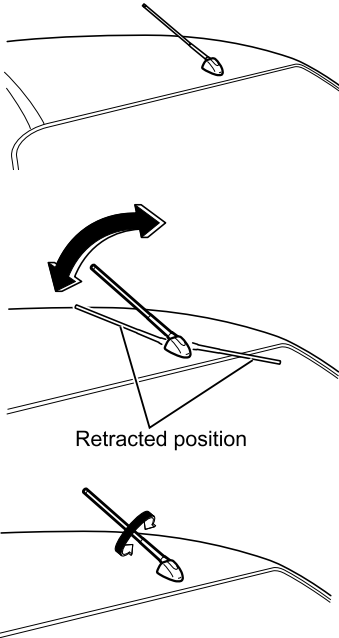

When receiving radio signals, adjust the angle of the antenna as appropriate. Turn the antenna rod counterclockwise to remove it.



ADVICE

- To prevent breaking the antenna when in an automatic car wash, remove the antenna. When the antenna has been removed in order to wash the vehicle, be careful not to misplace the antenna and be sure to reinstall it before driving the vehicle again.
- To prevent breaking the antenna, retract it when passing through areas with low clearance or when attaching a vehicle cover.

Pillar Type

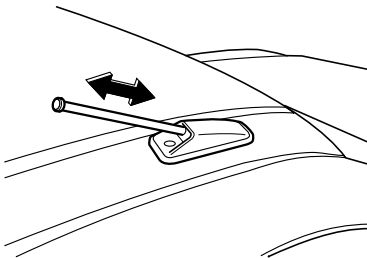

When receiving radio signals, pull the antenna out by hand to extend it to its full length.



ADVICE

- To prevent breaking the antenna, shorten it when passing through areas with low clearance or a car wash, or when attaching a vehicle cover.

Steering Wheel Remote Control

You can use the steering wheel remote control to perform various audio operations. The operations differ depending on the type of audio system that you use.

CAUTION

- While driving, be sure that audio control operations do not interfere with your driving.

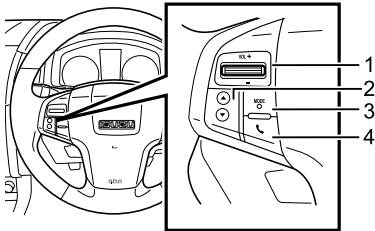

No.	Description
1	[VOL +/-] button
2	[▲], [▼] buttons
3	[MODE] button
4	[📞] button

Rear Vision Camera

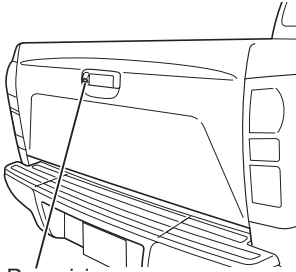

Rear vision camera

The rear vision camera is installed to the tailgate.



CAUTION

- Do not look only at the screen when driving the vehicle in reverse. Always inspect your surroundings by looking at them directly, and slowly move the vehicle.



ADVICE

- If the front cover of the lens is dirty, video will not be clear. If raindrops, snow, or dirt gets on the front cover of the lens, wipe it off with a soft cloth moistened with water. If you use a dry cloth to wipe the cover of the lens, it may be damaged.
- Do not subject the camera to strong shocks. It may break or become damaged, and a fire or electrocution may occur.
- Do not subject the camera to strong shocks from a high-pressure water stream, such as from a car wash. It may become damaged.
- Do not loosen the rear vision camera screws or disassemble the rear vision camera. The splash-proofing may be affected, and the camera may be damaged.



NOTE

- Raindrops may get on the camera area and obscure video.
- The rear vision camera uses a wide-angle lens, so objects in the screen may appear closer or farther than they appear.
- Video from the rear vision camera may be difficult to see or impossible to see in dark places or at night.
- The lens features a splash-proof construction to prevent fogging.
- Do not damage the camera area. Video from the camera may be affected.

SERVICE AND MAINTENANCE

6

BEFORE SERVICE AND MAINTENANCE

6-3

DAILY CHECKS

6-13

**ENGINE-RELATED SERVICE AND
MAINTENANCE**

6-17

**CHASSIS-RELATED SERVICE AND
MAINTENANCE**

6-57

OTHER SERVICE AND MAINTENANCE

6-95

**INTERIOR AND EXTERIOR
MAINTENANCE**

6-113

MAINTENANCE DATA

6-121

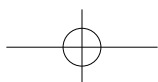
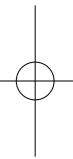
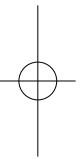
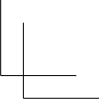
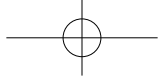
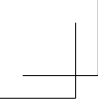

BEFORE SERVICE AND MAINTENANCE

• Precautions for Checking and Adjustments	6-4
• Discarded Parts, Oils and Other Liquids	6-6
• Isuzu Genuine Oils and Grease	6-6
• Tools	6-7
• Engine Hood	6-10

Precautions for Checking and Adjustments

Your Isuzu Dealer has factory trained technicians and Isuzu genuine parts to service your vehicle properly. For expert advice and quality service, see your Isuzu Dealer.

WARNING

- To help avoid personal injury, take care when doing any maintenance or making any check or repair. Follow the manufacturer's instructions for all materials used during service and maintenance of this vehicle. If used or handled improperly, they may be hazardous. Improper or incomplete service can also affect the vehicle and result in personal injury, or damage to the vehicle or its equipment. If you have any questions about carrying out some service, contact an Isuzu Dealer.
- Before performing any checks, in models with passive entry and start system, make sure to turn off the engine and switch the power mode to "OFF". In models without passive entry and start system, make sure to turn off the engine and remove the key from the starter switch.
- Pull firmly on the parking brake lever and put the transmission in neutral.
 - If your vehicle is equipped with a manual transmission, make sure the gearshift lever is in "N" position.
 - If your vehicle is equipped with an automatic transmission, place the selector lever in "P" position and make sure the shift indicator displays "P".
- Select a place with a solid and level surface to perform the checking and maintenance work. Make sure to chock the wheels. It would be very dangerous if the vehicle started to move.
- To prevent personal injury, keep hands, tools and clothing clear of the engine cooling fan when the engine is running.
- When raising the vehicle, use a suitable jack, not the one provided on the vehicle.
- After raising the vehicle and before going underneath to perform work, make sure the vehicle is supported with jack stands.
- When performing work on the electrical system, begin by switching the power mode to "OFF" (models with passive entry and start system) or turning the starter switch to the "LOCK" position (models without passive entry and start system), wait at least 1 minute, and then disconnect the negative cable from the negative terminal on battery. If the negative cable is disconnected within 1 minute, the engine control module may malfunction.

WARNING (Continued)

WARNING (Continued)

- The engine, diesel particulate defuser (DPD), muffler, exhaust pipe, radiator and power steering fluid reserve tank will be hot immediately after the vehicle is driven. In addition, the oil and fluids will also be hot. Be careful around these parts to prevent burns. Perform all checks when the engine is cold.
- Do not perform work near an open flame or other heat sources.
- When working on the fuel line or fuel filter, remove the fuel tank filler cap. The fuel system is under pressure and the fuel will overspill unless the pressure is relieved, possibly leading to combustion or a fire.
- Do not let the engine run in poorly ventilated garages or sheds. This could cause carbon monoxide poisoning, resulting in death.
- Hands, tools, or clothing could become entangled in the belts while the engine is in operation. Do not allow them to come close to the engine (remove wristwatches, neckties, rings, etc.).
- Fuel and batteries generate flammable gas that could explode. Do not use fire and avoid creating sparks.
- Protect your eyes with protective goggles from oil, fluids, and falling objects.
- Use only Isuzu genuine parts for replacement parts.

**CAUTION**

- Discarded parts, oil, grease and fluids could have an adverse effect on the environment. It is difficult to dispose of these, so have your Isuzu Dealer handle all checks and replacements.
- Oils, brake fluid, battery fluid and engine coolant have lubrication, cooling and rust prevention functions. If these liquids deteriorate through loss or contamination, it will cause a decline in the performance of the parts and such problems as seizure or malfunctioning. Replenish or change these liquids when performing the checks (daily and periodic checks) as required by the relevant regulations or in accordance with the Maintenance Schedule (when either the specified driving distance or period of time, whichever comes first, has expired).

**ADVICE**

- Use only appropriate tools.
- Confirm that all systems and components are normal after performing the work.
- Do not leave the removed parts or tools in the engine compartment. They could damage the equipment if caught in the belts or other moving components.
- Dirty water, dirt and other impurities seriously impair the effectiveness of the oil, grease and fluids, and damage the parts. Exercise all due caution to prevent waste or other refuse from coming in contact with parts or materials that have been removed when changing or replenishing them.

Discarded Parts, Oils and Other Liquids

- When changing oils, filters, engine coolant or other liquids, be sure to have a container ready in advance for their disposal.
- Use methods conforming to legal requirements for discarding or disposing of parts, oils, filters or engine coolant after change or replacement.

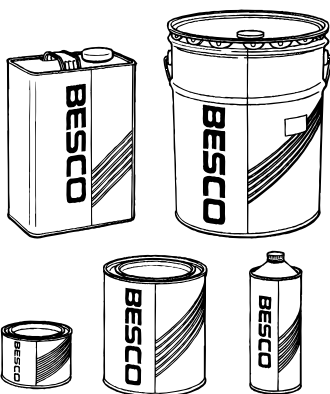
Isuzu Genuine Oils and Grease

Periodically replenishing and changing the oil and grease is extremely important for maintaining your vehicle's performance and preventing malfunctions.

Isuzu Motors guarantees the quality and performance of the Isuzu genuine oils and grease. We recommend the use of Isuzu genuine oils and grease for maintenance and service of your vehicle.

**CAUTION**

- Flames or other heat sources near spilled oil can cause a fire. Make sure to clean up all oil spills.

Tools



ADVICE

- It is recommended that you familiarize yourself with the contents and use of the various tools and the jack before using them.
- After finishing work with the tools, return them to the correct storage location and ensure that they will not move while the vehicle will be in motion.
- Store the jack in its original position and turn the jack socket clockwise so that it is secured (as a guide, with a force of **0.5 N·m** (0.05 kgf·m/**0.36 lb·ft**)).

Storage Location

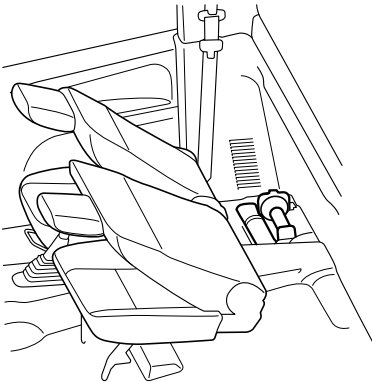

Regular Cab Model

The jack and tools are positioned behind the right seat. Tilt the seatbacks forward to take out the jack and tools. To remove the jack, turn the jack socket counterclockwise so that the ram is lowered away from the holder. Remove the jack when the ram is fully lowered.

Driver's Seat → Refer to page **3-49**



Extended Cab Model

The jack and tools are positioned in the storage compartment behind the right front seat. Open the cover to take out the jack and tools. To remove the jack, turn the jack socket counterclockwise so that the ram is lowered away from the holder. Remove the jack when the ram is fully lowered.

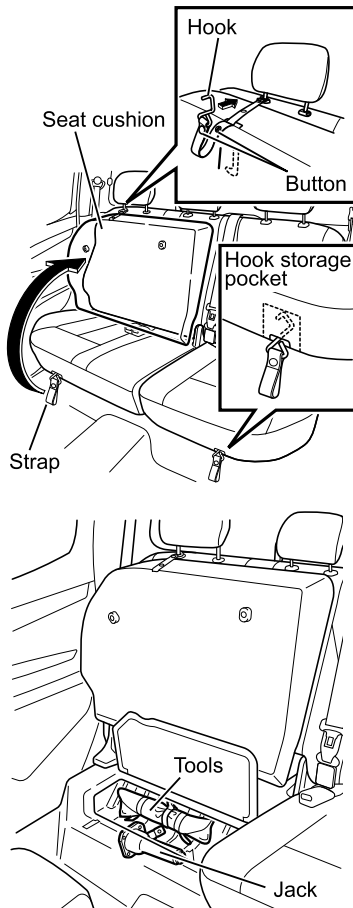

Crew Cab Model

The jack and tools are positioned under the right rear seat. Pull the strap forward to raise the seat cushion. Remove the hook of the strap edge from the strap button and secure the hook to the headrest stay. To remove the jack, turn the jack socket counterclockwise so that the ram is lowered away from the holder. Remove the jack when the ram is fully lowered.

⚠ WARNING

- Do not raise the seat cushion while driving.
- When raising the seat cushion, the hook of seat cushion strap must be secured to the headrest stay to keep the seat cushion locked safely in the storage position.
- When returning the seat cushion to its original position, hold the seat cushion and slowly lay it down. Finally, try to move the seat cushion to check that it is completely locked.
- After returning the seat cushion to its original position, do not forget to return the hook to the hook storage pocket.
- When returning the seat cushion to its original position, make sure the seat belt does not get trapped. In addition, make sure the seat belt lays on top of the seat cushion after returning the seat cushion to its original position.

Tools Carried in Your Vehicle

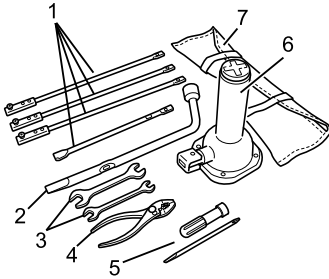

No.	Tool name
1	Jack bar/Spare tire removal bar
2	Wheel nut wrench (Jack handle)
3	Spanner
4	Pliers
5	Screwdriver (with switchable Phillips and flat heads)
6	Jack
7	Tool bag



ADVICE

- Be sure to carry all of the provided tools in the vehicle.

Engine Hood



WARNING

- Keep your hands and clothing away from the moving fan and engine drive belts when the engine is running.
- Upon inserting the support rod into the hood slot, make sure that the rod supports the hood securely to prevent injuries due to unexpected and sudden closing of the hood.
- Do not open the engine hood when steam is coming out of the engine compartment.



ADVICE

- Do not open the engine hood with the wiper arms standing. The wiper arms and engine hood may be damaged.

To Open

1. Pull the engine hood release lever.
The lock is released, and the front edge of the engine hood will rise.

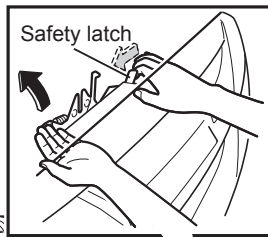
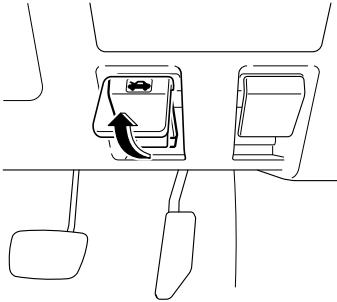

2. Insert a hand with its palm facing down into the space under the front edge of the engine hood, push the safety latch leftward to release the lock, and open the engine hood.

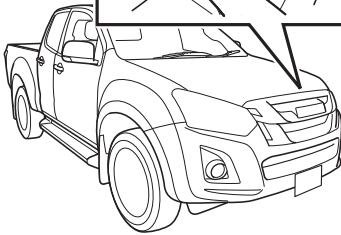

3. Remove the support rod from the clip, and then install the support rod edge hook into the groove of the engine hood.

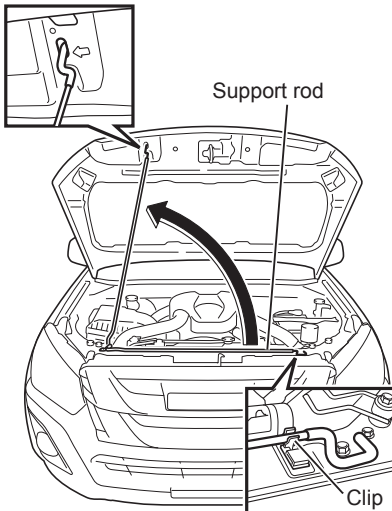

6-12 SERVICE AND MAINTENANCE

To Close

WARNING

- The engine hood is very heavy. When you close the engine hood, be careful not to trap your hands or anything else.

ADVICE

- Do not drop the engine hood from a height of over 60 cm (23.6 in). The engine hood and radiator grille may be damaged by the impact.

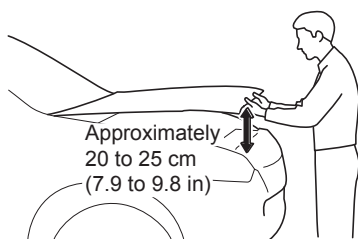

1. Remove the support rod from the groove of the engine hood and install it into the clip.
2. Lower the engine hood slowly, and release your hands at a height of approximately 20 to 25 cm (7.9 to 9.8 in).
3. Gently push and pull the edge of the engine hood to make sure that it has been securely locked in place.

WARNING

- Do not drive unless the engine hood is complete closed. Driving with the engine hood open could lead to an accident. Before driving, confirm that the engine hood is securely locked.

DAILY CHECKS

• Daily Checks (Preoperational Checks)	6-14
• Checking Components that Showed Abnormalities during Previous Operation	6-16

Daily Checks (Preoperational Checks)

Check your vehicle for the items listed below before starting the day's operation to ensure safe, trouble-free operation. Also, make note of the distance the vehicle has covered and the conditions under which the vehicle has been operated to be able to determine the inspection intervals most appropriate for your specific vehicle and adequately service it according to inspection results.

If the checks reveal an abnormality or if there are components that showed abnormalities during the previous operation, have the vehicle repaired by your Isuzu Dealer before using the vehicle.

Daily Check (Preoperational Check) Items

[1. Checking components that showed abnormalities during the previous operation]

Check item	Reference page
Checking components that showed abnormalities during the previous operation	6-16

[2. Checks performed with the engine hood opened]

Check item	Reference page
Fan belt looseness and damage	6-47
Engine oil level	6-20
Engine coolant level and radiator cap looseness	6-40
Power steering fluid level	6-93
Brake fluid level (For a manual transmission model, brake fluid doubles as clutch fluid.)	6-58, 6-90
Windshield washer fluid level	6-96
Battery fluid level	6-101

[3. Checks performed in the driver's seat]

Check item	Reference page
Brake pedal free play	6-60
Operation of meters, gauges and warning/indicator lights	4-16, 4-26
Engine startability, abnormal noise and color of exhaust gases	6-18
Parking brake lever stroke	6-63
Windshield washer fluid spray condition and windshield wiper effectiveness	6-96, 6-97
Rearview mirror condition	3-59
Steering wheel free play and mounting condition	3-58, 6-92
Operation of horn and turn signal lights	4-123, 4-129
Fuel level	4-23
Operation of door locks	3-7, 3-13, 3-26

[4. Checks performed during a walk around the vehicle]

Check item	Reference page
Illumination, flashing or for stained or damaged lights	6-100
Suspension springs damage	—
Leakage of oil, engine coolant, fuel, brake fluid, and power steering fluid	—

[5. Checking wheels and tires]

Check item	Reference page
Air pressure	6-64
Cracks and other damage	6-66
Abnormal wear	6-66
Tread depth	6-66
Disc wheel mounting condition	6-67

[6. Checks performed while driving the vehicle]

Check item	Reference page
Brake effectiveness	6-62
Driving condition at low speeds and during acceleration	6-19

Checking Components that Showed Abnormalities during Previous Operation

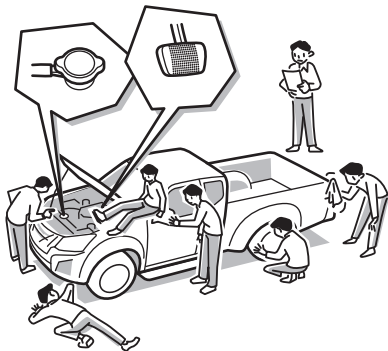

Check the components that showed abnormalities during the previous operation. Have any abnormalities repaired by your Isuzu Dealer before using the vehicle.

**ENGINE-RELATED SERVICE AND
MAINTENANCE**

• Engine Conditions	6-18
• Engine Oil	6-20
• Engine Coolant	6-40
• Handling the Radiator and Intercooler	6-45
• Fan Belt/Air Conditioning Compressor Belt/Accessory Belt	6-47
• Air Cleaner	6-50
• Fuel Filter	6-53

Engine Conditions

Checking the Engine for Startability and Abnormal Conditions

1. Make sure the parking brake is securely engaged. Step firmly on the brake pedal.
2. If your vehicle is a manual transmission model, check that the gearshift lever is in the "N" position, and fully depress the clutch pedal.
In an automatic transmission model, check that the selector lever is in the "P" position, and firmly depress the brake pedal.



CAUTION

- If your vehicle is equipped with the automatic transmission, the engine will not start unless the transmission is actually in "P" or "N" position.
- For safety, firmly press the brake pedal before starting the engine.

3. Push the engine start/stop button (models with passive entry and start system) or turn the starter switch (models without passive entry and start system) to start the engine.
Check that the engine starts quickly without any abnormal conditions (abnormal noises, vibration, etc.). If there are any abnormalities, stop the engine and contact your nearest Isuzu Dealer.

Starting the Engine

→ Refer to page 4-4

Checking Condition of the Engine at Low Speeds and during Acceleration



1. Make sure that the parking brake lever is fully pulled.
If your vehicle is a manual transmission model, make sure that the gearshift lever is in the "N" position and then depress the clutch pedal and brake pedal fully.
In an automatic transmission model, make sure that the selector lever is in the "P" position and then depress the brake pedal fully.
2. Push the engine start/stop button (models with passive entry and start system) or turn the starter switch (models without passive entry and start system) to start the engine, and run it to warm up.

Starting the Engine

→ Refer to page 4-4

3. Check that the engine is running at a speed within the standard idle speed range.
4. Drive the vehicle, making sure the accelerator pedal does not stick when gradually accelerating, the engine speed rises smoothly and it does not knock. If there are any abnormalities (accelerator pedal sticking, rough engine acceleration, knocking, etc.), stop your vehicle at a safe place, stop the engine, and contact your nearest Isuzu Dealer.

Engine Oil

Engine oil is an important factor in determining engine performance and longevity. Be sure to use only specified oil and oil filter. The engine oil level must be checked and the oil and oil filter should be regularly changed at the same time according to the Maintenance Schedule.



NOTE

- When particulate matter (PM) has accumulated to a preset level in the diesel particulate defuser (DPD), the DPD is automatically regenerated through combustion. To make this regeneration (combustion) possible, a small amount of fuel is injected into the engine combustion chamber after combustion. A small amount of the injected fuel gradually mixes with the engine oil, and the engine oil level rises beyond the original level. This does not indicate an engine malfunction. If the engine oil level exceeds the "Inspection MAX" mark of the oil dipstick, change the engine oil even if the regular oil change period on the Maintenance Schedule has not arrived yet.

Engine Oil Indicator Light

→ Refer to page 4-79

Maintenance Schedule

→ Refer to page 6-122

Recommended Fluids, Lubricants and

Diesel Fuels → Refer to page 6-130

Checking the Engine Oil Level

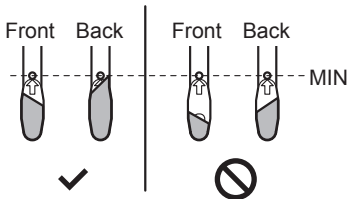
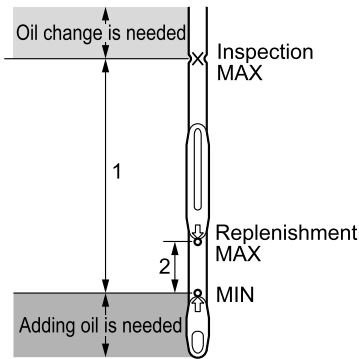
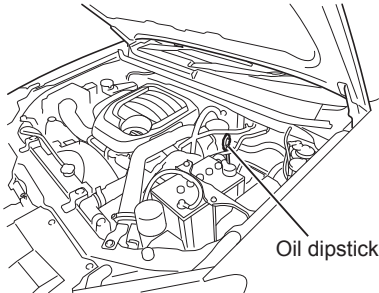

Perform the engine oil level check on a flat surface while the engine is cold before starting it. If the engine has already been started, stop it after it has sufficiently warmed and wait 30 minutes or more before performing.

1. Remove the oil dipstick and wipe off any oil on the oil dipstick.
2. Reinsert the oil dipstick fully and then gently remove it.
3. Check the front and back of the oil dipstick. If the highest position is between the "MIN" and "Inspection MAX" marks (range 1), the oil is at the correct level.

- If the oil level is below the "MIN" mark, add oil by following the procedures detailed on the following pages.
- If the oil level is beyond the "Inspection MAX" mark, have engine oil replacement performed at your Isuzu Dealer. If you perform replacement yourself, please replace the oil by following the procedures detailed on the following pages.

**ADVICE**

- If the oil level is higher than the "MIN" mark, there is a sufficient amount of oil. In this case, the engine oil supply does not need to be replenished.

4. Reinstall the oil dipstick into position after checking the oil level.

**ADVICE**

- Any oil level above the "Inspection MAX" mark on the oil dipstick may cause engine malfunctions. Change the oil whenever its level exceeds the "Inspection MAX" mark.
- Fuel will gradually become mixed with the engine oil, thinning it out. Be sure to change the oil at the specified intervals.
- The oil level read by the oil dipstick changes depending on the amount of time that elapses after the engine is turned off. In order to confirm the correct oil level, perform the check while the engine is cold before starting it. If the engine has already been started, stop it after it has sufficiently warmed and wait 30 minutes or more before performing.

Adding the Engine Oil

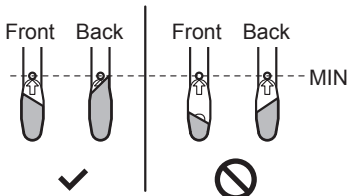
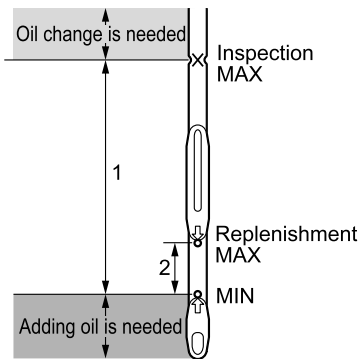
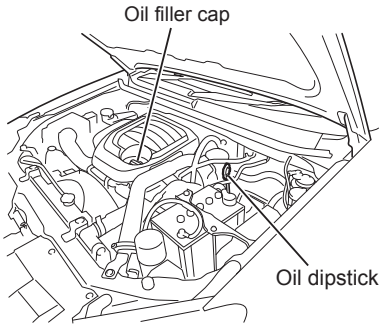

If the oil level is found to be below the "MIN" mark on the oil dipstick as a result of the oil level inspection, add engine oil by following the procedure below.

Add engine oil on a flat surface while the engine is cold before starting it. If the engine has already been started, stop it after it has sufficiently warmed and wait 30 minutes or more before performing.

1. Clean around the oil filler cap so that foreign matter does not enter.
2. Remove the oil filler cap.
3. Fill with **0.3 liters** (0.08 US gal./**0.07 Imp gal.**) of the specified oil through the oil filler.
4. Install the oil filler cap.
5. Wait 5 minutes or more without starting the engine.
6. Remove the oil dipstick and wipe off any oil on the oil dipstick.
7. Reinsert the oil dipstick fully and then gently remove it.
8. Check the front and back of the oil dipstick. If the highest position is higher than the "MIN" mark, the oil is at the correct level.
 - If the "Replenishment MAX" mark is exceeded, drain oil until the level is between the "MIN" and "Replenishment MAX" marks (range 2).
 - If below the "MIN" mark, return to Step 2 and repeat the procedure for adding **0.3 liters** (0.08 US gal./**0.07 Imp gal.**) of the specified oil.
9. Reinstall the oil dipstick into position after checking the oil level.

**WARNING**

- When adding oil, be careful not to spill any, but keep a workshop rag handy just in case there are any spills. If any oil should spill onto the engine, carefully wipe it away. If this precaution is not taken, the spilled oil could ignite and a fire could spread.
- Do not leave flammable items, such as rags or gloves, in the engine compartment. They could cause a fire.
- The engine oil and the area surrounding the engine are hot immediately after engine operation, so be careful of burns.

**ADVICE**

- The oil level read by the oil dipstick changes depending on the amount of time that elapses after the engine is turned off. In order to confirm the correct oil level, perform the check while the engine is cold before starting it. If the engine has already been started, stop it after it has sufficiently warmed and wait 30 minutes or more before performing.
- Prevent dirt from entering the oil filler when filling with oil. If foreign matter mixes with the oil, it could damage the engine.
- Always use low ash content engine oil. Failing to do so could result in DPD failure.

**NOTE**

- If the oil level is above the "MIN" mark, there is a sufficient amount of oil.

Changing the Engine Oil and Oil Filter

Engine oil and the oil filter are important factors in determining engine performance and longevity. Be sure to use only specified oil and oil filter. The engine oil level must be checked and the oil and oil filter should be regularly changed at the same time according to the Maintenance Schedule.

WARNING

- Hot engine oil can cause severe skin burns. Allow the engine to cool before draining the engine oil.

ADVICE

- Use the oil quantities indicated below only as guidelines when changing the engine oil. After changing the oil, make sure the oil is at the required level.
- Always use low ash content engine oil. Also, do not use engine oil additives. Failing to do so could result in DPD failure.

Quantity of engine oil to be changed

Engine model	Oil quantity [Reference value]
	When changing oil and filter
4JK1 (2WD)	5.4 liters (1.43 US gal./1.19 Imp gal.)
4JK1 (4WD)	5.9 liters (1.56 US gal./1.30 Imp gal.)
RZ4E (2WD/4WD)	6.6 liters (1.74 US gal./1.45 Imp gal.)

Maintenance Schedule

→ Refer to page 6-122

Recommended Fluids, Lubricants and

Diesel Fuels → Refer to page 6-130

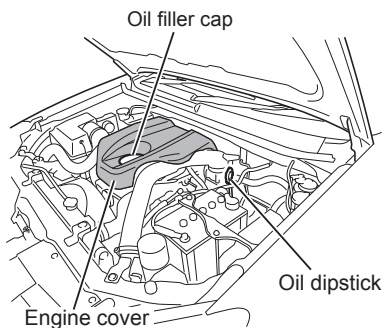
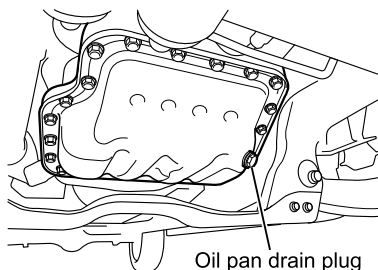
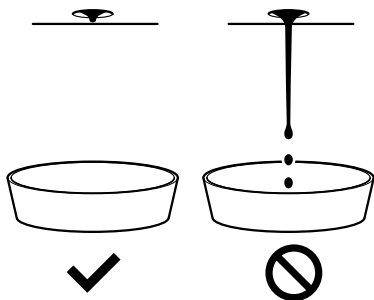
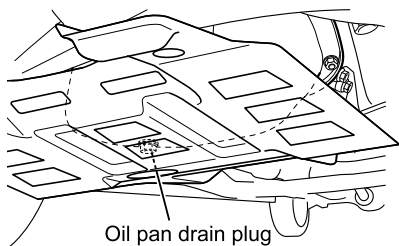
**2WD model****4WD model****Changing the Oil and Oil Filter (4JK1 Engine Model)**

Change the engine oil and oil filter on a flat surface while the engine is cold before starting it. If the engine has already been started, stop it after it has sufficiently warmed, wait 30 minutes or more, and perform after confirming that the oil has sufficiently cooled.

1. Remove the engine cover.
2. Clean around the oil filler cap so that foreign matter does not enter.
3. Remove the oil filler cap.
4. Place a container for receiving the oil beneath the oil pan. Remove the oil pan drain plug to discharge the oil into the container.
5. Wait until the flow of oil stops and the oil pools into a drop inside the oil pan drain hole.

**ADVICE**

- If the engine oil is not sufficiently drained from the oil pan, the oil level may be too high when oil is replenished.
- Drained oil must be disposed of in a method conforming to the regulatory requirements in your country.

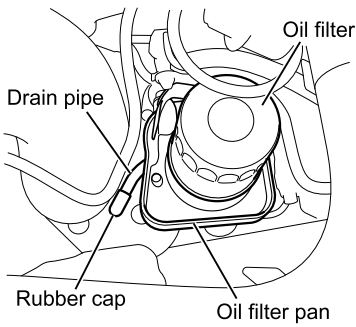
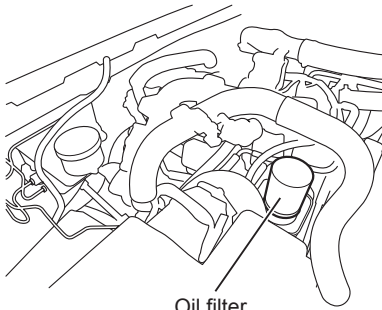

6. Remove the oil filter in one of the following procedures:

- When replacing the oil filter without using a drain hose, use the special oil filter wrench to remove the oil filter.

When the oil from the oil filter spills out into the oil filter pan, remove the oil from the oil filter pan. Wipe away any spilled oil with a workshop rag, etc.

- When replacing the oil filter using a drain hose, remove the rubber cap attached to the end of the drain pipe for the oil filter pan and attach a commercially available drain hose to the drain pipe before removing the oil filter. Then, place a container under the end of the drain hose after pulling the hose to the bottom of the engine.

Use the special oil filter wrench to remove the oil filter.

Drain any oil remaining in the oil filter pan from the drain hose into the container. After oil drainage is complete, remove the drain hose and attach the rubber cap. Wipe away any spilled oil with a workshop rag, etc.



ADVICE

- Drained oil must be disposed of in a method conforming to the regulatory requirements in your country.



NOTE

- Engine oil will spill out from the removed oil filter, so catch the engine oil with a workshop rag, etc.

7. Lightly coat the gasket of the new oil filter with clean engine oil.
8. Wipe the attachment surface of the oil filter clean with a rag, etc.
9. Install the new oil filter. After the filter gasket comes in contact with the surface to which it will be attached, use the special oil filter wrench and tighten it by a 2/3 (two thirds) turn.

**ADVICE**

- When installing the oil filter, make sure the gasket is not caught in the screw threads. This could cause oil leaks.

10. Replace the oil pan drain plug gasket. Reinstall and tighten the oil pan drain plug.

Drain plug tightening torque

83 N·m (8.5 kgf·m/61 lb·ft)

**ADVICE**

- The dirt and oil on the following parts must be wiped off before reinstalling the oil pan drain plug.
 - Thread of the oil pan drain plug
 - Thread of the oil pan drain hole
 - Bolt seat surface of the oil pan
11. Measure the specified quantity of the specified oil.
 12. Remove the oil dipstick and pour the specified quantity of oil once from the oil filler.
 13. Install the oil dipstick and the oil filler cap.
 14. Wait 5 minutes or more without starting the engine.

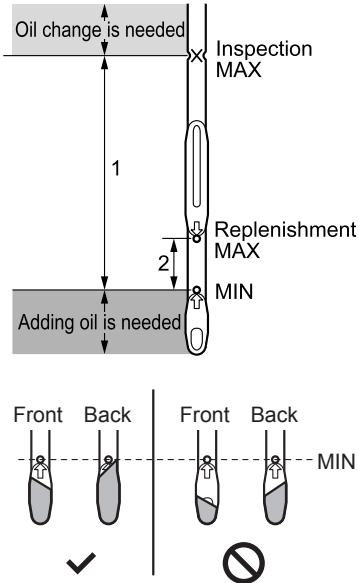

15. Remove the oil dipstick and wipe off any oil on the oil dipstick.
16. Reinsert the oil dipstick fully and then gently remove it.
17. Check the front and back of the oil dipstick. If the highest position is higher than the "MIN" mark, the oil is at the correct level.
 - If the "Replenishment MAX" mark is exceeded, drain oil until the level is between the "MIN" and "Replenishment MAX" marks (range 2).
18. Reinstall the oil dipstick into position after checking the oil level.
19. Reinstall the engine cover.

WARNING

- Bringing flames or other heat sources near spilled engine oil could cause a fire. Make sure to wipe it all up.
- Do not leave flammable items, such as rags or gloves in the engine compartment. They could be the cause of a fire. Also, do not forget your tools.

ADVICE

- Do not start the engine until the oil level has been checked, because it will become impossible to confirm the correct oil level.

NOTE

- If the oil level is above the "MIN" mark, there is a sufficient amount of oil.

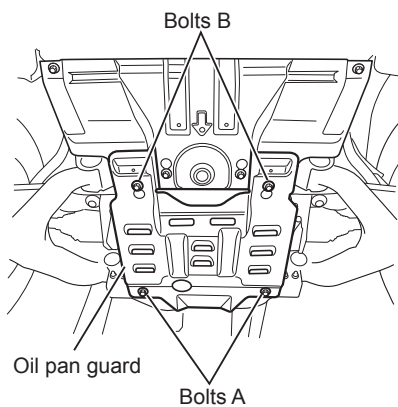

Changing the Oil and Oil Filter (RZ4E Engine Model)

Change the engine oil and oil filter on a flat surface while the engine is cold before starting it. If the engine has already been started, stop it after it has sufficiently warmed, wait 30 minutes or more, and perform after confirming that the oil has sufficiently cooled.

1. In models with an oil pan guard, remove the oil pan guard. While securely supporting the oil pan guard, loosen bolts A and B and remove the oil pan guard.

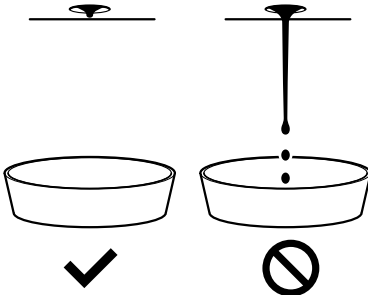
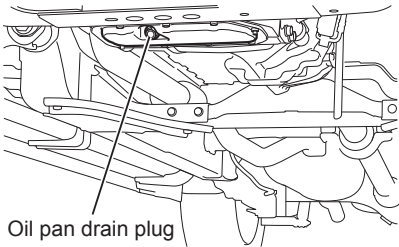
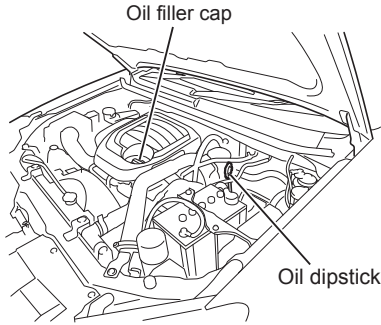

2. Clean around the oil filler cap so that foreign matter does not enter.
3. Remove the oil filler cap.
4. Place a container for receiving the oil beneath the oil pan. Remove the oil pan drain plug to discharge the oil into the container.
5. Wait until the flow of oil stops and the oil pools into a drop inside the oil pan drain hole.

**ADVICE**

- If the engine oil is not sufficiently drained from the oil pan, the oil level may be too high when oil is replenished.
- Drained oil must be disposed of in a method conforming to the regulatory requirements in your country.

- Pull the tab of clip A, clip B, clip C, clip D, and clip E in the direction of the arrow and remove clips from the stays while unlocking.

**ADVICE**

- When removing, do not apply excessive force to the tab of the clip and do not attempt to forcibly remove the clip while the lock is not released. Doing so may result in clip breakage.

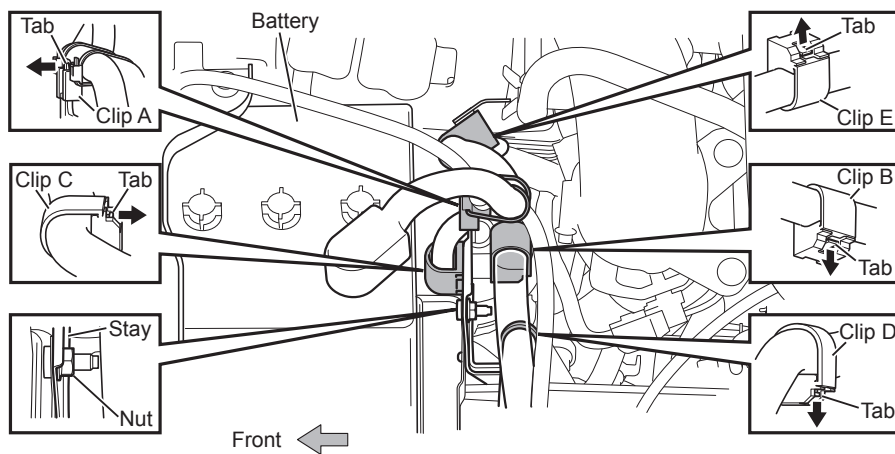

- Loosen the nut and remove the stay.

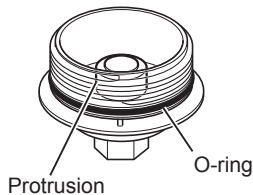
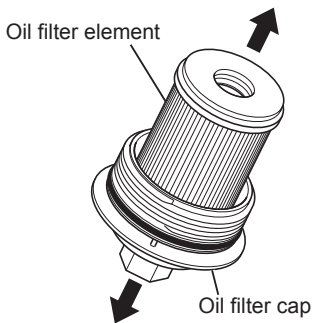
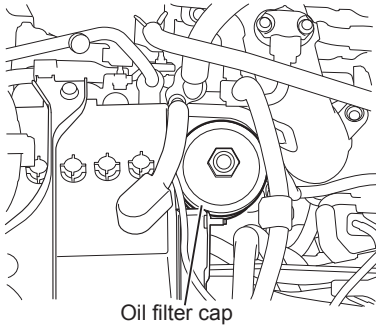

8. Using a socket wrench, loosen the oil filter cap.
9. Wait for approximately 30 seconds.
10. Remove the oil filter cap.

**ADVICE**

- If you remove the oil filter cap immediately after loosening, engine oil may overflow.

11. Remove the oil filter element from the oil filter cap.

**ADVICE**

- Drained oil must be disposed of in a method conforming to the regulatory requirements in your country.

**NOTE**

- Engine oil may drip from the removed oil filter. Catch the engine oil with a workshop rag, etc.
12. To ensure that the new oil filter element makes good contact, wipe the protrusion inside the oil filter cap using a clean workshop rag, etc.
 13. Remove the O-ring from the oil filter cap and wipe the O-ring mounting surface using a clean workshop rag, etc.
 14. Install a new O-ring to the oil filter cap.

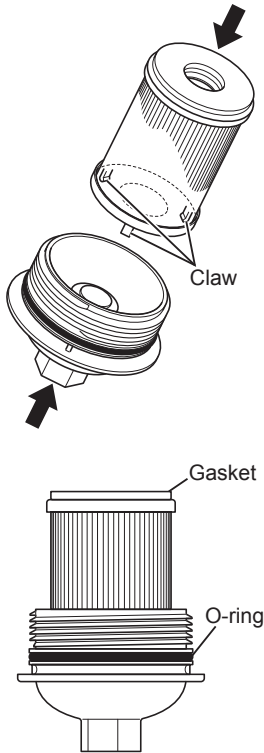

15. Face the claw side of the new oil filter element towards the oil filter cap, and install by firmly pushing it in until the claws latch on.
16. Make sure that the oil filter element and oil filter cap are installed straightly.

17. Lightly coat the gasket of the new oil filter element and the O-ring of the oil filter cap with clean engine oil.
18. Install and tighten the oil filter cap by hand. Finally, tighten the cap to the specified torque using a torque wrench.

Oil filter cap tightening torque

25 N·m (2.5 kgf·m/18 lb·ft)



ADVICE

- When installing, make sure the gasket and O-ring are not caught in other parts. This could cause oil leaks.

19. Install the stay and tighten the nut to the specified torque using a torque wrench.

Stay nut tightening torque

7 N·m (0.7 kgf·m/5 lb·ft)

20. Install clips to the stays.
21. Replace the oil pan drain plug gasket. Reinstall and tighten the oil pan drain plug.

Drain plug tightening torque

83 N·m (8.5 kgf·m/61 lb·ft)



ADVICE

- The dirt and oil on the following parts must be wiped off before reinstalling the oil pan drain plug.
 - Thread of the oil pan drain plug
 - Thread of the oil pan drain hole
 - Bolt seat surface of the oil pan

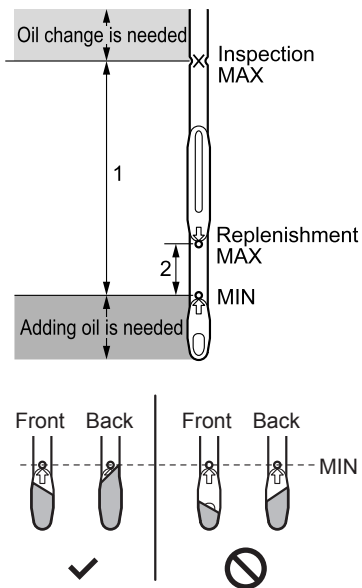

22. Measure the specified quantity of the specified oil.
23. Remove the oil dipstick and pour the specified quantity of oil once from the oil filler.
24. Install the oil dipstick and the oil filler cap.
25. Wait 5 minutes or more without starting the engine.
26. Remove the oil dipstick and wipe off any oil on the oil dipstick.
27. Reinsert the oil dipstick fully and then gently remove it.
28. Check the front and back of the oil dipstick. If the highest position is higher than the "MIN" mark, the oil is at the correct level.
 - If the "Replenishment MAX" mark is exceeded, drain oil until the level is between the "MIN" and "Replenishment MAX" marks (range 2).
29. Reinstall the oil dipstick into position after checking the oil level.

WARNING

- Bringing flames or other heat sources near spilled engine oil could cause a fire. Make sure to wipe it all up.
- Do not leave flammable items, such as rags or gloves in the engine compartment. They could be the cause of a fire. Also, do not forget your tools.

**ADVICE**

- Do not start the engine until the oil level has been checked, because it will become impossible to confirm the correct oil level.

**NOTE**

- If the oil level is above the "MIN" mark, there is a sufficient amount of oil.

30. In models with an oil pan guard, reinstall the oil pan guard.

Oil pan guard tightening torque

90 N·m (9.2 kgf·m/66.4 lb·ft)

31. To update the information in the engine control module after replacing the engine oil, confirm that the engine is stopped.
32. Confirm that the parking brake is securely engaged. For manual transmission models, confirm that the gearshift lever is in the "N" position. For automatic transmission models, confirm that the selector lever is in the "P" position.

Parking Brake Lever

→ Refer to page 4-137

Gearshift Lever

→ Refer to page 4-138

Selector Lever

→ Refer to page 4-141

33. Switch the power mode to "ON" (models with passive entry and start system) or turn the starter switch to the "ON" position (models without passive entry and start system).

**CAUTION**

- Do not start the engine until the update operation has completed. It is not possible to complete the update operation safely and properly with the engine running.

Engine Start/Stop Button (Models with Passive Entry and Start System)

→ Refer to page 4-116

Starter Switch (Models without Passive Entry and Start System)

→ Refer to page 4-119

SVS indicator light



34. Depress the accelerator pedal fully. Depressing the accelerator pedal for approximately 20 seconds will cause the SVS indicator light to start flashing slowly (approximately 1 time/second).

**WARNING**

- When depressing the accelerator pedal, ensure that the engine is stopped. If the engine is running when depressing the accelerator pedal, the vehicle will suddenly move, causing a serious accident.

Service Vehicle Soon (SVS) Indicator Light

→ Refer to page 4-84

35. Continue to depress the accelerator pedal, and approximately 40 seconds after the SVS indicator light starts to flash slowly, it will change to a fast flash (approximately 3 times/second). After the SVS indicator light has flashed fast for approximately 2 seconds, the update operation completes.

**ADVICE**

- Forgetting the update operation when replacing the oil may cause the SVS indicator light to illuminate erroneously because the oil change information is not determined correctly.

**NOTE**

- If the update operation does not complete properly, consult your Isuzu Dealer.

Engine Coolant

The engine cooling system is a device for keeping the engine temperature at an appropriate level.

The engine coolant must be changed according to the Maintenance Schedule.

Have engine coolant replacement performed at an Isuzu Dealer.

Maintenance Schedule

→ Refer to page 6-122

Recommended Fluids, Lubricants and

Diesel Fuels → Refer to page 6-130

WARNING

- Check, replenish or change the engine coolant only after the engine has sufficiently cooled down.
- Do not loosen or remove the cap of the radiator or reserve tank cap when the engine coolant is still hot. Hot vapor or boiling water may burst out and cause a burn. Cover the cap with a cloth, etc. and remove it gradually after the engine is fully cooled down and the temperature of the engine coolant becomes low.
- When removing the radiator cap or reserve tank cap, use a thick cloth to cover the cap and turn it slowly.
- Engine coolant is toxic and must not be ingested. If the engine coolant is mistakenly ingested, immediately vomit it and seek prompt medical attention.
- If the engine coolant gets in your eyes, rinse it off immediately with a large amount of water for 15 minutes or longer. Also, if still abnormality such as irritation is felt, seek medical attention.
- If the engine coolant gets on your skin, rinse it off using a soap with a large amount of water. Also, if abnormality is seen, seek medical attention.
- Engine coolant is flammable, and therefore, it must be kept away from flames and other heat sources. Engine coolant also could ignite if it comes in contact with a hot surface, such as the exhaust manifold. Exercise caution to prevent this from happening.

ADVICE

- Replace the engine coolant periodically.
If the engine coolant is not replaced periodically, rust is generated due to degradation of the engine coolant, which may cause a failure such as water leakage or clogging of the radiator or heater core.

**NOTE**

- Engine coolant is fluid which is made by mixing coolant and water at an appropriate concentration.

Preparing Engine Coolant

To prevent the engine damage due to freezing of the engine coolant and to protect the cooling system from corrosion, mix the Isuzu recommended coolant and water to be an appropriate concentration.

Outside temperature	Coolant concentration*
-30°C (-22°F) or above	50%

* Direct use of "50/50 Pre-diluted" product which is already diluted to 50% concentration is recommended.

Recommended Fluids, Lubricants and Diesel Fuels → Refer to page 6-130

**ADVICE**

- Isuzu does not guarantee the use of the engine or vehicle at the outside temperature of -30°C (-22°F) or below.
- However, if the engine or vehicle is used at the outside temperature of -30°C (-22°F) or below, the coolant concentration of 55% is recommended.

**WARNING**

- Coolant is toxic and must not be ingested. If the coolant is mistakenly ingested, immediately vomit it and seek prompt medical attention.
- If the coolant gets in your eyes, rinse it off immediately with a large amount of water for 15 minutes or longer. Also, if still abnormality such as irritation is felt, seek medical attention.
- If the coolant gets on your skin, rinse it off using a soap with a large amount of water. Also, if abnormality is seen, seek medical attention.
- For storage, close the cap securely and keep it in a place inaccessible to children.
- Coolant is flammable, and therefore, it must be kept away from flames and other heat sources. Coolant also could ignite if it comes in contact with a hot surface, such as the exhaust manifold. Exercise caution to prevent this from happening.

**CAUTION**

- Use only an Isuzu recommended coolant.
- Using any coolant other than that Isuzu recommended could cause damage to the engine, radiator or heater core. In particular, use of coolants containing amines, borate salts or silicates may result in engine or radiator corrosion, causing engine coolant leaks and other problems.
- Do not use water alone.

**ADVICE**

- To dilute the coolant, use distilled water or deionized water.
- Do not use the coolant at any coolant concentration other than that specified. If the coolant concentration is 60% or higher, overheating is likely to occur, while if it is 30% or lower, anti-corrosion function is not provided sufficiently.
- Using coolant at any coolant concentration other than that specified may reduce anti-freezing performance, and engine coolant may freeze.
- If the engine coolant decreases rapidly, go immediately to the nearest Isuzu Dealer for a check or repair.
- Do not introduce additives to engine coolant other than coolant.

Checking the Engine Coolant Level

4JK1 engine model

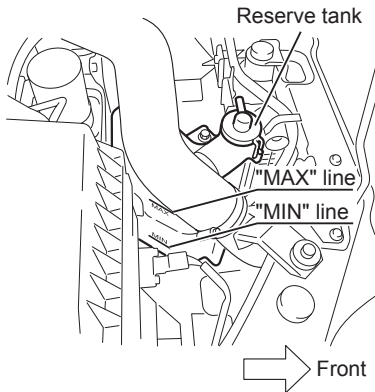

RZ4E engine model

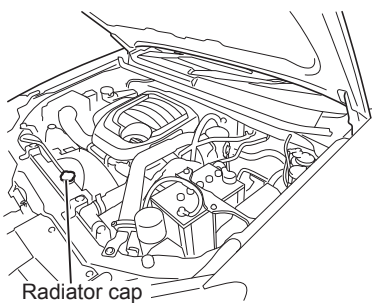
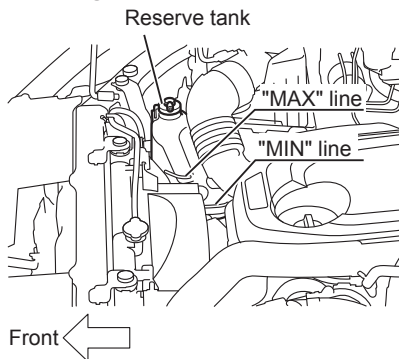

The reserve tank is located at the front right side of the engine compartment. When the engine has cooled down, make sure that the engine coolant level in the reserve tank is between the "MAX" and "MIN" line.

In addition, remove the radiator cap and check that the engine coolant is full to the filler neck. Check the engine coolant level only when it is cold.

Engine Hood → Refer to page 6-10

⚠ CAUTION

- The radiator cap opens and closes in double action. When removing the radiator cap, take caution not to damage the cap and the filler neck.

Also, check to make sure there are no leaks from the radiator or radiator hose. Check for fluid or stains on the ground showing leaks where the vehicle is parked. Contact your Isuzu Dealer when you discover leaks.

⚠ CAUTION

- Using the vehicle when there are leaks can lead to engine seizure.

Adding the Engine Coolant

4JK1 engine model

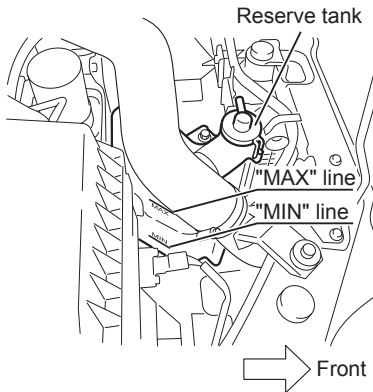

When the engine coolant level in the reserve tank is below the "MIN" line, open the tank cap and fill to near the "MAX" line with engine coolant. Tighten the cap securely after the engine coolant has been replenished.

Engine Hood → Refer to page 6-10

WARNING

- Check, replenish or change the engine coolant only after the engine has sufficiently cooled down.

RZ4E engine model

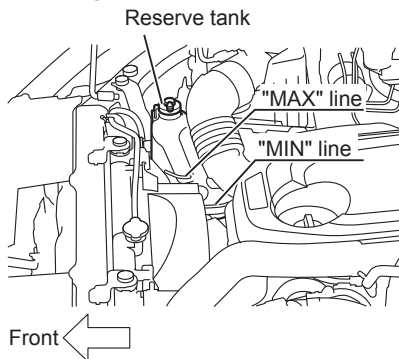

ADVICE

- Do not overfill the reserve tank.
- Check the reserve tank to determine engine coolant level. In situations, however, where the level in the reserve tank rises or falls suddenly, open the radiator cap and check the level within the radiator itself.
- When the engine is still hot, take care to prevent engine coolant from contact with the exhaust manifold. Any such contact could result in exhaust manifold damage.
- If the level of engine coolant changes rapidly, have your vehicle inspected at your Isuzu Dealer.

Handling the Radiator and Intercooler

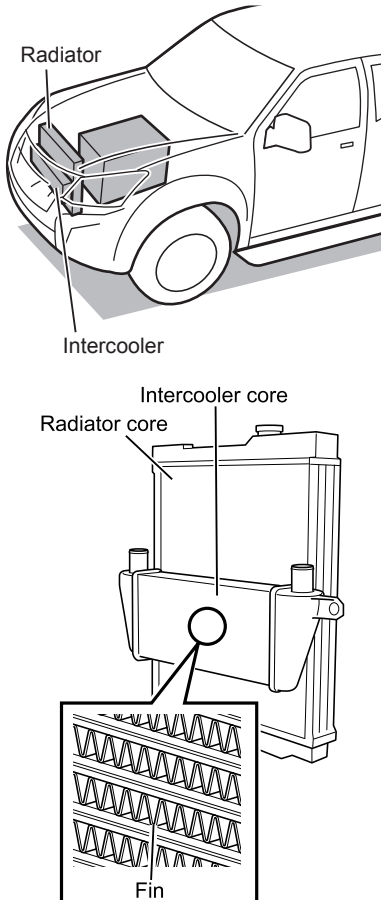

Cleaning the Radiator Core and Intercooler Core

Cooling efficiency is compromised when there is dirt or dust plugging air passages in the radiator core and intercooler core. This can also cause corrosion of these cores. Periodically wash the radiator core and intercooler core with tap water.

WARNING

- Before cleaning cores, in models with a passive entry and start system, make sure to turn the engine off and switch the power mode to "OFF". In models without a passive entry and start system, make sure to turn the engine off and remove the key from the starter switch.
- The area around the engine is extremely hot immediately after vehicle operation, so wait until the vehicle has cooled down before cleaning. Otherwise, you could be burned.

CAUTION

- When washing the radiator core and intercooler core, make sure that they have sufficiently cooled. Otherwise, the cores could be damaged.
- Do not clean the radiator, intercooler and their surrounding areas using water that is supplied under high pressure. Doing so may cause damage.
- When cleaning the radiator core and intercooler core, do not crush or damage the fins.

CAUTION (Continued)

CAUTION (Continued)

- The fins are very fragile so be careful not to bend them out of shape. If they become deformed, their cooling efficiency will be impaired.
- Before cleaning, take steps to ensure that no water will splash onto the surrounding electrical components and wires.
- If stubborn dirt still remains even after the radiator core and intercooler core have been cleaned, have the vehicle inspected and serviced at your Isuzu Dealer.

Fan Belt/Air Conditioning Compressor Belt/Accessory Belt**CAUTION**

- A V-ribbed belt is used for the fan belt of the 4JK1 engine. This type of belt requires the tension to be adjusted more accurately than is required with the conventional V belt. Inappropriate tension could cause the belt to make noise or break. When the fan belt is damaged, electricity is not properly generated or becomes a cause of engine overheating. You must check the tension of the fan belt carefully.
- Inappropriate tension could cause the belt to make noise or break. You must check the tension of the air conditioning compressor belt carefully.
- Use Isuzu genuine parts when changing the fan belt and air conditioning compressor belt.

[Follow this to properly adjust belt tension]

- Adjust the belt using the following method after installing either a new or used belt.
 - Inspect the belt before starting the engine or 30 minutes after turning off the engine to cool down.
 - Align the belt and pulley grooves and adjust the belt tension using the indicated method.
 - Start the engine, and let it idle for about 1 minute to equalize the tension of the belt at all spans between the pulleys.
 - Stop the engine, and then check the belt tension. If the tension is inappropriate, readjust it to the specified standard value.
 - Use the new belt tension specification only after replacing the belt with a new one.

Inspection

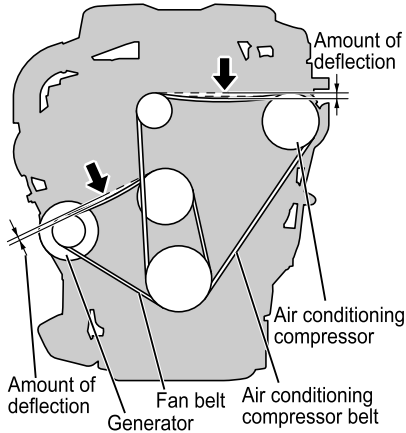

4JK1 Engine Model

Press the center of the span between pulleys (see the figure) of the belt with a force of **98 N (10.0 kgf/22 lb)** and check the amount of deflection. The amount of deflection must fall within the standard value range indicated below. Otherwise, adjust the tension.

When inspecting by vibration frequency, place and hold the sensor mic surface parallel to the belt 10 mm (0.39 in) from the center of the span between pulleys (indicated by the arrow) and tap the belt with a handle of screwdriver etc. to make the belt vibrated and measure the value. Measure the value 2 or 3 times and calculate the average value. The average value must be within the standard value range indicated below. Otherwise, adjust the tension.

Also check the belt for cracks or other damage. If there are any cracks or damage, replace the belt. Have adjustment and replacement of the fan belt or air conditioning compressor belt performed at an Isuzu Dealer.

	Standard value [amount of deflection]	Standard value [vibration frequency]
Fan belt	7.7 - 8.5 mm/0.30 - 0.33 in (New belt: 5.4 - 6.6 mm/0.21 - 0.26 in)*	160 - 174 Hz (New belt: 188 - 210 Hz)*
Air conditioning compressor belt	16.5 - 19.1 mm/0.65 - 0.75 in (New belt: 12.5 - 16.5 mm/0.49 - 0.65 in)*	79 - 91 Hz (New belt: 92 - 112 Hz)*

*: The values in parentheses are the adjusted values for replacement with a new belt.

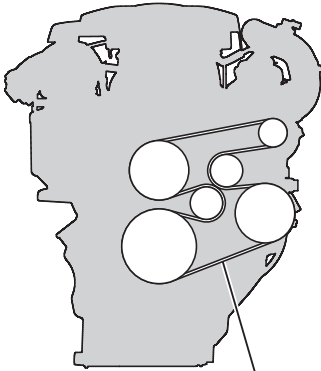

Accessory belt

RZ4E Engine Model

The tension of the accessory belt is automatically adjusted using an auto-tensioner.

Check the accessory belt for cracks or damage. Also, run the engine to check for belt squealing or looseness. If there are any cracks, damage, squealing, or looseness, replace the accessory belt. Have replacement performed at an Isuzu Dealer.

**WARNING**

- When performing checks with the engine running, take care to prevent hands, feet, clothing, or any accessories from coming into contact with moving parts, such as cooling fan or belts.

Starting the Engine

→ Refer to page 4-4

Air Cleaner

Use of clogged air cleaner element not only causes a deterioration in the engine output but also increased fuel consumption. The air cleaner element should be serviced in the following manner.

The air cleaner element must be inspected and changed according to the Maintenance Schedule. Have air cleaner element replacement performed at an Isuzu Dealer.



ADVICE

- Be sure to use an Isuzu genuine air cleaner element.
- The cover should be reinstalled after aligning correctly to prevent dust from entering. The engine air cleaner should be installed at all times unless temporary removal is necessary during repair or maintenance of the vehicle. Absence of the air cleaner could cause damage to the engine.

Air Cleaner Element Indicator Light

→ Refer to page 4-80

Maintenance Schedule

→ Refer to page 6-122

Inspection and Cleaning of the Air Cleaner

Remove the air cleaner element and check to see if it is blocked by dirt.

If air cleaner element is blocked by dirt, clean the air cleaner element.

1. Unfasten the two clips and open the air cleaner cover.

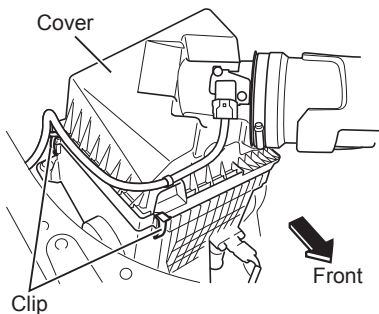

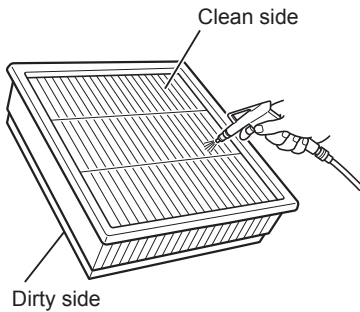
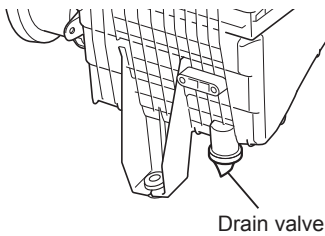
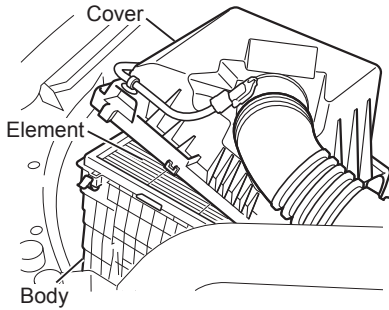

2. Remove the air cleaner element by pulling it out upward.
3. Remove any dirt that has accumulated on the inside of the air cleaner body.

4. Clean the drain valve at the bottom of the air cleaner.

5. Blow compressed air at a pressure of up to **690 kPa** (7.0 kgf/cm² / **100 psi**) against the clean side of the element to remove the dust.

**ADVICE**

- Do not apply compressed air to the dirty side of the element as it causes dust to become lodged in the element.

6. Check to see if the element has been damaged or become thin in places.

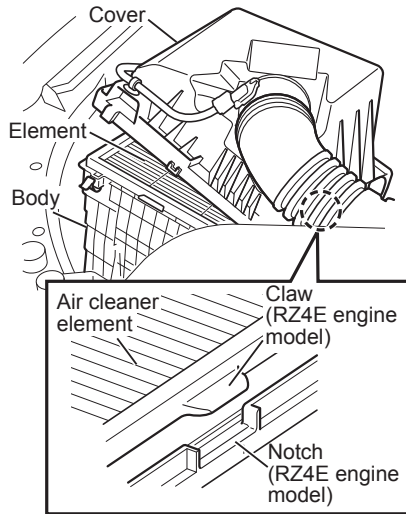

7. For 4JK1 engine models, reinstall the air cleaner element.
For RZ4E engine models, align the claw of the air cleaner element with the notch of the air cleaner body and reinstall it.
8. Close the air cleaner cover and fasten the two clips of the air cleaner body.

Fuel Filter

Change the fuel filter in accordance with the Maintenance Schedule. Have fuel filter replacement performed at an Isuzu Dealer.

Drain the water when the water separator (fuel filter) warning light comes on.

Maintenance Schedule

→ Refer to page 6-122

Water Separator (Fuel Filter) Warning Light

Water separator (fuel filter) warning light

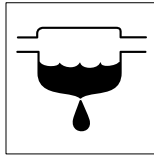

Warning message (models with MID)



In models with an MID, when a certain amount of water has collected in the water separator (the engine side fuel filter), the water separator (fuel filter) warning light comes on after the warning message is displayed on the MID for approximately 3 seconds and then goes out.

In models with an LCD, when a certain amount of water has collected in the water separator (the engine side fuel filter), the water separator (fuel filter) warning light comes on.

When this happens, drain the water and make sure that the warning light has gone out.



CAUTION

- Water remaining that is not discharged from the water separator could freeze and damage the vehicle.
- If the warning light comes on while the engine is in operation, immediately drain the water from the water separator (fuel filter). Continuing to drive with the light remaining on could damage the fuel injection system. If this happens, have the vehicle checked and serviced by the nearest Isuzu Dealer.

Draining Water from the Fuel Filter

→ Refer to page 6-54

Draining Water from the Fuel Filter

Have water separator (fuel filter) drain work performed at an Isuzu Dealer. If performing water separator (fuel filter) drain work yourself, dispose of the oil in a method conforming to the regulatory requirements in your country.

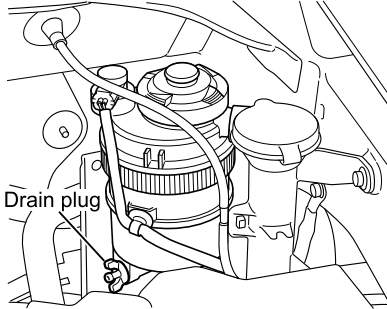

1. The fuel filter is located at the rear left side of the engine compartment. Connect one end of a plastic hose to the drain plug at the bottom of the fuel filter and place the other end of the hose inside a container to receive the drained fluid.

WARNING

- Perform drain work in a location without any flammable material. Failure to do so could cause a fire.
2. Loosen the drain plug and move the priming pump up and down by hand between 10 and 20 times.
 3. Fully tighten the drain plug and move the priming pump several times.
 4. Test run the engine and check that there are no fuel leaks from the drain plugs of the fuel filter. Also check that the water separator (fuel filter) warning light stays off.

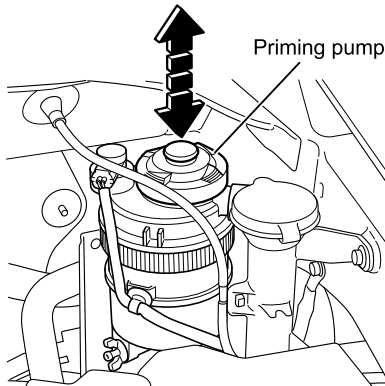

**CAUTION**

- Be sure to stop the engine when draining water from the fuel filter.
- Clean off any fuel that has adhered to the vehicle body.
- Starting the engine immediately after draining the water from the fuel filter requires a little more time than usual. If the engine does not start in 10 seconds, wait for a while and try again.
- Fuel will be mixed in the drained water. Dispose of it in a method conforming to the regulatory requirements in your country.
- If the water separator (fuel filter) requires frequent draining, have the fuel tank drained at your Isuzu Dealer. It would be better not to use the water separator (fuel filter), since it may possibly exert a bad effect on the fuel system.



**CHASSIS-RELATED SERVICE AND
MAINTENANCE**

• Brakes	6-58
• Parking Brake	6-63
• Wheels and Tires	6-63
• Tire Rotation	6-69
• Spare Tire	6-70
• Handling the Jack	6-74
• Changing Tires	6-79
• Clutch (Manual Transmission Model)	6-90
• Automatic Transmission Fluid (Automatic Transmission Model)	6-91
• Steering Wheel	6-92
• Power Steering Fluid	6-93

Brakes



WARNING

- If there are abnormalities with the brake system, avoid driving the vehicle and contact the nearest Isuzu Dealer.

Brake Fluid

For a manual transmission model, the tank of the brake fluid is common with a tank of the clutch fluid.



WARNING

- If the brake fluid gets in your eyes, rinse it off immediately with a large amount of water for 15 minutes or longer. Also, if still abnormality such as irritation is felt, seek medical attention.



CAUTION

- Before refilling the tank, clean the area around the cap and fill brake fluid from a clean container. Foreign objects getting in the tank will lead to a brake system failure.
- Inspect and change brake fluid according to the Maintenance Schedule.
- Use non-petroleum base brake fluid when adding brake fluid.
- Be careful not to let brake fluid come in contact with skin. If fluid comes into contact with skin, wash away the fluid with water.
- Brake fluid melts paintwork and vehicle component materials such as plastic, vinyl and rubber. It is also highly corrosive on metals. If it is spilled, immediately wipe the area clean or wash away the fluid with water.
- If skin irritation persists, check with a doctor.
- Brake fluid readily absorbs moisture. Therefore, it is necessary to close the container tightly for storage.
- Do not mix brake fluid with fluids of a non-specified brand. Due to chemical reactions, any mixture of differently branded fluids will cause failure of the brake system.

CAUTION (Continued)

CAUTION (Continued)

- If the brake fluid level decreases rapidly, there may be a problem in the brake system or brake pads or shoe linings may have worn out. Have your vehicle inspected by the nearest Isuzu Dealer immediately.

Maintenance Schedule

→ Refer to page 6-122

Recommended Fluids, Lubricants and**Diesel Fuels** → Refer to page 6-130**Checking the Brake Fluid Level**

Check that the fluid level in the reserve tank is between the "MAX" and "MIN" lines.

Be sure to use the brake fluid compartment section when checking the "MIN" line section of the brake fluid level. The brake fluid level cannot be accurately checked if the brake fluid level is checked with a method other than the brake fluid compartment section.

If the fluid surface cannot easily be seen, rock the vehicle gently.

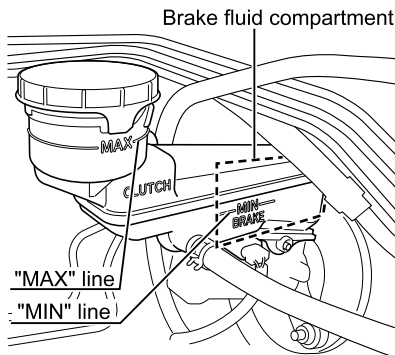
**CAUTION**

- Be sure to check the fluid level correctly. The clutch and brake fluid level varies when the brake pads are worn out.

Adding Brake Fluid

If the level of brake fluid has dropped below the "MIN" line, remove the cap and add fluid. Take care to avoid filling beyond the "MAX" line.

Tighten the cap securely after the fluid has been added.

Changing Brake Fluid

Change the brake fluid according to the Maintenance Schedule using the specified fluid. Since a brake fluid change requires disassembly of the related components, have this service performed by your Isuzu Dealer.

Brake Pedal

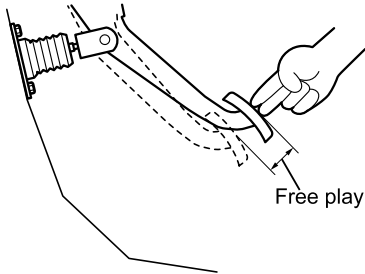

Free Play

Shut off the engine and depress the brake pedal about 10 times strongly, then check the brake pedal for free play by lightly pushing it by hand until you feel resistance. If the free play is not within the specified range, have your vehicle inspected and adjusted by an Isuzu Dealer.

Free play (measured at the tip of pedal)

6 - 10 mm (0.24 - 0.39 in)

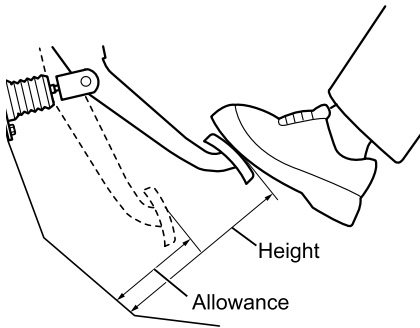

Height and Allowance

Inspect the brake pedal height from the floor.

Next, start the engine, wait at least 1 minute and inspect the brake pedal allowance from the floor with the brake pedal in a depressed position.

If the height and allowance are not within the specified range, have your vehicle inspected and adjusted by an Isuzu Dealer.

Transmission model	Height	
	Right-hand drive models	Left-hand drive models
Manual transmission models	177.4 - 189.4 mm (6.98 - 7.46 in)	176.3 - 188.3 mm (6.94 - 7.41 in)
Automatic transmission models	179.6 - 191.6 mm (7.07 - 7.54 in)	178.5 - 190.5 mm (7.03 - 7.50 in)

Allowance (pressure of 490 N (50 kgf / 110 lb) applied to the brake pedal)

85 mm (3.35 in) or more

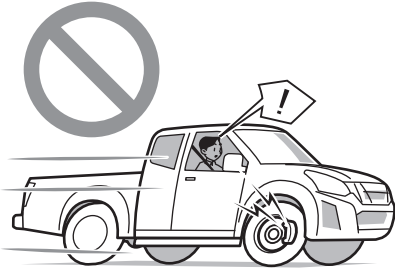
**ADVICE**

- If, after continued pressing of the brake pedal, the clearance slowly decreases or the pedal action feels spongy, air may be trapped in the brake hydraulic circuit. Have your vehicle inspected at the nearest Isuzu Dealer as soon as possible.
- If your vehicle's brakes squeak during normal driving or braking, the cause may be one of the following.
 - Brake pad wear
Brake pads are about to wear out. If this happens, have your vehicle inspected at the nearest Isuzu Dealer as soon as possible.
 - Adherence of sand, grit or mud
If sand, grit or mud adheres to the brakes, a screeching sound may be emitted upon contact with rotating components. If this happens, wash the vehicle to remove all such adhering matter. If cleaning alone does not eliminate the squeaking sound, have your vehicle inspected at the nearest Isuzu Dealer as soon as possible.

**NOTE**

- To check the clearance of the pedal from the floor, start the engine, depress the accelerator pedal a few times, and use the first pressing of the brake pedal to measure the clearance. The clearance cannot be correctly measured after pressing the pedal two or more times in succession.

Brake Performance

Run the vehicle slowly on a dry road and apply the brakes. Check that the brakes fully work and the vehicle does not pull on one side. If there are problems with brake performance, avoid driving the vehicle and contact the nearest Isuzu Dealer.



CAUTION

- A brake performance check should be performed on a wide road with good visibility while paying adequate attention to the traffic behind and the surroundings.

Brake Hoses and Pipes

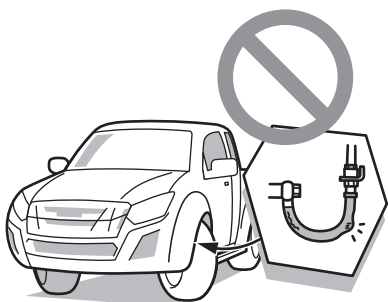

With the steering wheel turned fully to the left, check the left front brake hose and pipe visually and by touch, making sure that they are free of scratches, cracks and bulging. Also make sure that the hose and pipe do not interfere with any chassis part or wheel, and that their joints are not leaking and free of any type of damage. Check the right front brake hose and pipe in the same way. The rear left and right brake hoses and pipes should also be checked. If there are abnormalities with the brake hoses or pipes (damage, scratches, cracks, bulging, leakage, etc.), avoid driving the vehicle and contact the nearest Isuzu Dealer.

Parking Brake

Inspection

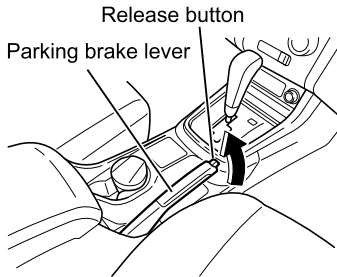

Pull the parking brake lever slowly from the fully released position while counting the clicks produced as the lever engages ratchet plate notches to check that it can be raised the proper amount and the lever is held firmly. If the number of notches is not within the standard value range below, adjust it to the standard value. Also, on a dry sloping road, check that the parking brake can hold the vehicle stationary.

Have adjustment of the parking brake and inspections for parking brake performance performed at an Isuzu Dealer.

Lever stroke*
6 to 9 notches

*:Number of notches before parking brake is set when lever is pulled slowly from released position with pull force of about **294 N (30 kgf/66 lb)**.

Wheels and Tires

The wheels have a major influence upon the safety and comfort of driving. Should any wheel fall off the vehicle, it not only causes the vehicle to breakdown on the road and block other traffic, but it may also lead to a serious accident. We strongly recommend that you check the wheels and tires daily and maintain them in satisfactory condition.



WARNING

- Do not drive the vehicle unless the tires are properly inflated and in safe condition.
- If you find anything abnormal with wheel bolts, wheel nuts, disc wheels or tires when you check them, avoid driving the vehicle and contact the nearest Isuzu Dealer.
- If you find anything abnormal on the left wheels, check the right wheels carefully for similar defects. A defect on a wheel may be a sign of defects on other wheels.

Checking Tires

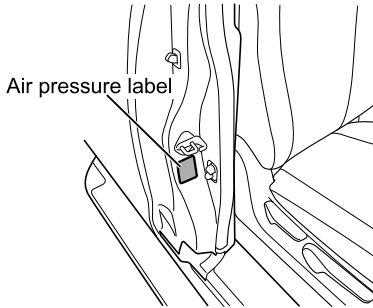
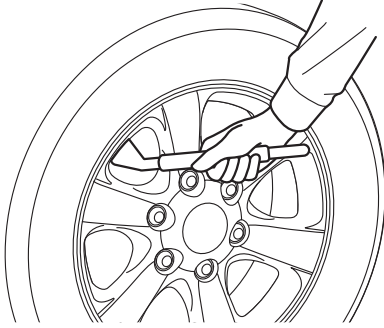

Air Pressure

Too low or too high a tire air pressure not only affects the ride or causes damage to the cargo but also causes abnormal heat buildup, premature wear, a tire puncture, or may even cause the tire to burst.

- Use an appropriate tire air pressure gauge when measuring the air pressure of a tire. Tire air pressure should be measured when the tire is cold, or before the vehicle is driven. (After driving, tire air pressure increases by about 10%.)
- As the tire air pressure varies depending on the vehicle model and tire size, refer to the air pressure label on the driver's door opening frame if the air pressure label is attached or the tire air pressure tables on the following pages if the air pressure label is not attached.
- Also check the air pressure of the spare tire using a tire air pressure gauge at the intervals specified by the Maintenance Schedule.

Tire Size and Tire Air Pressure

Vehicle model	Tire size		Tire air pressure kPa (kgf/cm ² / psi)	
	Front	Rear	Front	Rear
2WD	215/70R15C		225 (2.25/33)	375 (3.75/54)
2WD High-Ride/ 4WD	245/70R16		200 (2.00/29)	280 (2.80/41)
	255/65R17		200 (2.00/29)	250 (2.50/36)
	255/60R18		200 (2.00/29)	250 (2.50/36)

**WARNING**

- Insufficiently inflated or worn-out tires are highly dangerous as they easily skid and can even burst. Should they burst, the tires may burn and this could cause a fire in the vehicle.
- If you drive on under-inflated or flat tires, the wheel bolts will be placed under excessive stress. Under such conditions, the bolts may break and the wheel may detach from the vehicle, possibly causing an accident.

**CAUTION**

- Over-inflated tires result in a harsh ride and are likely to cause damage to the cargo. Under-inflated tires build up heat and could burst. Always keep the tires of your vehicle adjusted at the standard air pressures.

Cracks and Other Damage

Check the tread and sidewall surfaces of each tire for cracks or other damage. Especially check the tread for nails or other metal pieces embedded in grooves.

If you find anything abnormal with tires when you check them, avoid driving the vehicle and contact the nearest Isuzu Dealer.



ADVICE

- When checking tires, pay special attention to: low air pressure; pebbles or nails in tread grooves; cracks or other damage on tire surfaces; uneven wear.

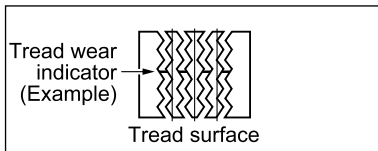
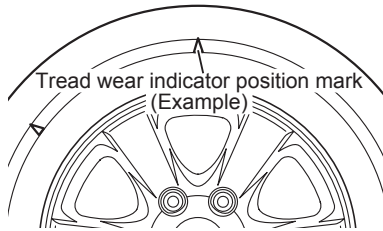

Tread Depth and Abnormal Wear

Using worn-out tires is dangerous because they might have an increased chance of getting punctured or bursting while driving. Check all tires to see if tread wear indicators appear on their treads and also check their entire tread for its depth with a depth gauge to make sure that the grooves are deeper than the specified depth.

A tire with tread wear indicators appearing must be changed. Also, check the tires for uneven or otherwise abnormal wear.

If the tires are worn, contact your Isuzu Dealer as soon as possible.



CAUTION

- Tires with excessively shallow tread grooves will increase the chance of skidding and, when driving at high speeds, hydroplaning.

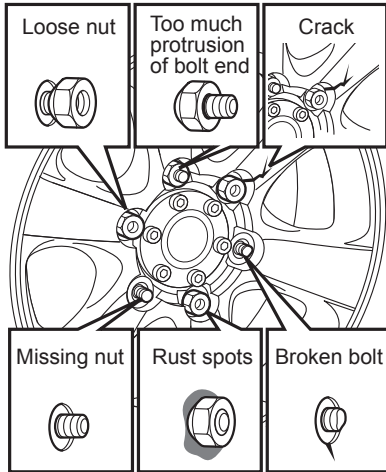

Visual Checking of Wheel Installation Condition

Visually check the condition of installation of each disc wheel.

1. Check that there are no missing wheel bolts and wheel nuts.
2. Check each disc wheel to see if there is any rust seepage from wheel bolts or nuts. Also check the disc wheel for cracks or other damage.
3. Check the end of each wheel bolt for proper length of protrusion from the wheel nut. The protrusion should be uniform among all bolts on a wheel and among all wheels. If you find anything abnormal with wheel bolts, wheel nuts or disc wheels when you check them, avoid driving the vehicle and contact the nearest Isuzu Dealer.



CAUTION

- Any abnormality in wheel installation is likely to lead to loose or missing wheel nuts and/or broken wheel bolts.

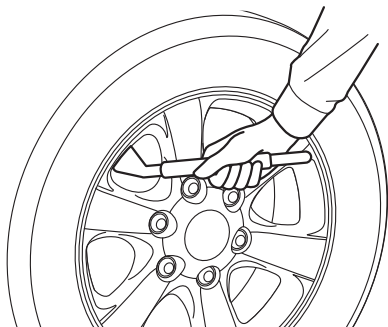

Spare Tire Air Pressure

Keep the air pressure of the spare tire slightly higher than the standard pressure. Adjust the pressure correctly when you use it.

Tires heat up while driving, and their air pressures become higher accordingly. If you must wait until right after driving to adjust the air pressure, determine the target pressure for adjustment by adding about **20 kPa** (0.2 kgf/cm² / **3 psi**) to the standard pressure.

Tires Used for Long Term

Tires are made of rubber whose property changes gradually by aging as time goes on (even when it is stored fitted on the rim like a spare tire). Tires must receive an aging check after being used for up to 5 to 7 years if they are to be used continuously. For further details, please contact your Isuzu Dealer.

Tire Rotation

**CAUTION**

- Be sure to check the wheel bolts, wheel nuts and disc wheel for any abnormality whenever the disc wheel is removed.
- If you find any abnormal condition on the wheel bolts, wheel nuts or disc wheel, do not continue to use the wheel. Contact the nearest Isuzu Dealer as soon as possible.

Tires at different locations wear differently. For uniform tire wear and longer tire life, you should rotate the tires on your vehicle regularly.

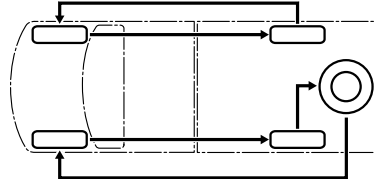
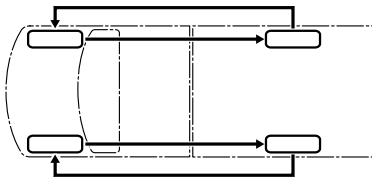

If one-sided tire wear appears on radial tires, rotate the wheels as shown in the below figure.

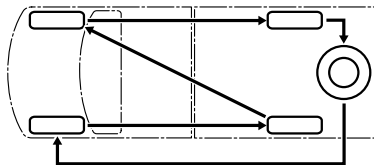
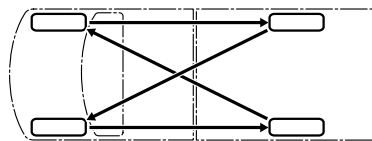
**ADVICE**

- The tightening torque of the wheel nuts may decrease after a tire change due to their initial settlement. Upon driving 50 to 100 km (31 to 62 miles) after a tire change, retighten the wheel nuts to the specified torques according to the instructions in the "Retightening Wheel Nuts" section in this chapter.
- The spare tire disc wheel is steel (not aluminum). It is for emergency use only for vehicles that are equipped with an aluminum wheel (do not use in the rotation sequence).

Retightening Wheel Nuts

→ Refer to page 6-89

Spare Tire

Removal

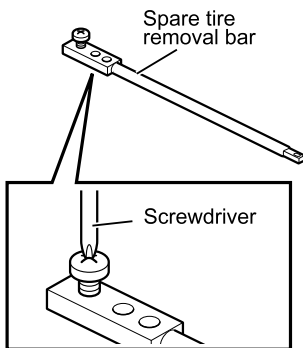
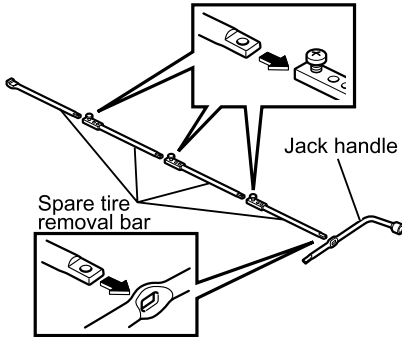

1. Assemble the spare tire removal bars and jack handle.

2. When assembling the spare tire removal bars to each other, tighten the joint bolts by hand or with a screwdriver (Phillips head). Make sure that the concave side is facing the bolt side of the other bar before tightening the bolt.

 **CAUTION**

- Make sure that each screw joint is tightened properly.

 **ADVICE**

- All the joint bolts should be tightened properly or the bars may become loose and hit the body panel, causing damage to the panel or paint.
- To prevent paint damage, place several pieces of paper above painted parts.

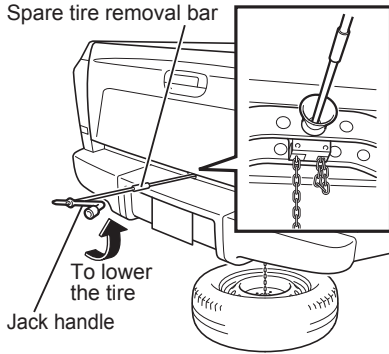

3. Insert the spare tire removal bar into the hole in the spare tire carrier, and turn the jack handle counterclockwise to remove the spare tire.

Storage

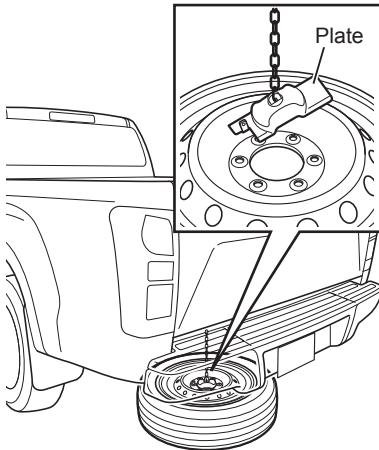

1. Set the disc wheel so that its outer surface faces up, and then insert the plate into the center of the disc wheel.



NOTE

- When storing aluminum wheels, make sure that the wheel cover is removed.

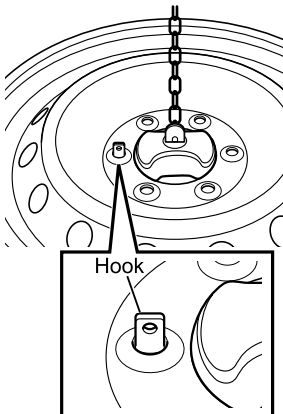

2. Insert the hook of the plate into the disc wheel nut hole and adjust its position for secure engagement with the spare tire before winding the chain up.

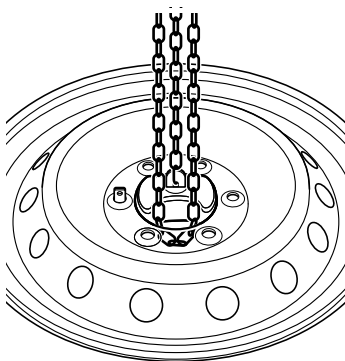
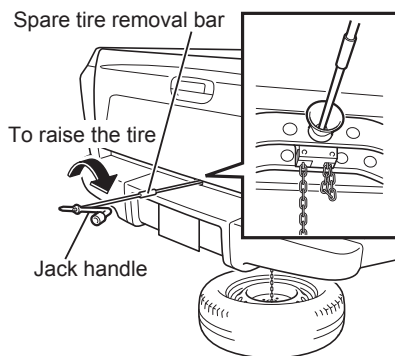

3. Let the chain rest in the center of the disc wheel while it is raised halfway. Then turn the jack handle to lift up the tire.

Turn the spare tire removal bar clockwise to fully wind up the chain, apply at least **196 N (20 kgf/44 lb)** of force to the jack handle by hand, and make sure that the spare tire is firmly secured in place.

**CAUTION**

- Do not remove the spare tire while the vehicle is jacked up.
- If the chain twisted when it is wound, it becomes loose while running due to vibrations or shocks and the tire might fall off; this is very dangerous.
- After storing the tire in the carrier, check that the tire is held firmly. If loosely retained, the tire becomes loose while running due to vibrations or shocks and the tire might fall off; this is very dangerous.

**ADVICE**

- After storing the spare tire, check that it is not loose by strongly pushing the tire with your foot. If the tire is loose, fasten it again after checking that there are no defects in the carrier such as a bent bracket or hanger plate. If you cannot retighten the tire in the carrier, avoid driving the vehicle and contact the nearest Isuzu Dealer.

Air Pressure

Check the air pressure of the spare tire using a tire air pressure gauge at the intervals specified in the Maintenance Schedule.

A spare tire inflated to a normal pressure may lose its pressure gradually over time due to leaks. You should therefore inflate it to a pressure a little higher than the normal over time pressure.

Maintenance Schedule

→ **Refer to page 6-122**



Handling the Jack



WARNING

- Raising the vehicle with a jack could lead to an accident when carried out on soft or inclined surfaces. Ensure that you always carry out this operation on flat, solid surfaces.
- Do not place any objects above or below the jack while performing the jacking operation.
- Always apply the parking brake fully and correctly chock the wheels with the gearshift lever in the "R (reverse)" position for manual transmission models and "P" for automatic transmission models before jacking the vehicle. A vehicle blocked only with the parking brake could move, creating a very dangerous situation when the rear wheels are jacked up.
- To lock the steering wheel, in models with passive entry and start system, place the front wheels in a straight position, switch the power mode to "OFF", then open or close the driver side door. In models without passive entry and start system, place the front wheels in a straight position and remove the key from the starter switch.
- Ensure that there are no people or objects present in the vehicle before it is jacked up.
- In order to ensure safety, doors should never be opened and the engine should never be started during a jack-up operation.
- The jack must only be used at one of the specified jacking points. In addition, you must confirm that it makes good contact with the specified point.
- In order to provide extra safety should the jack slip, once a spare tire has been removed, it should be placed under the vehicle near the jack.
- Before starting a jacking operation, ensure that the jack and the jacking point to be used are clear of dirt, oil and grease. Failure to observe this precaution could lead to an accident should the dirt or oil cause the jack to slip.
- It might start moving when the engine power is transmitted to the rear axle even when one of the wheels on the axle is raised clear of the ground. Do not start the engine with any rear wheel in contact with the ground.
- The jack provided with your vehicle must be used only for changing defective tires and fitting or removing tire chains. In order to ensure safety, furthermore, only one wheel should be jacked up at a time.
- Do not use more than one jack at any one time.
- Lifting up both wheels at the same time is very dangerous. Be sure to jack up one wheel at one time.

WARNING (Continued)

WARNING (Continued)

- The jack supplied with your vehicle is specifically for that vehicle. Do not use it on another vehicle and never use another vehicle's jack.
- Be sure that the jack bar is tightly inserted into the jack handle before turning the handle and bar. Serious personal injury can result if the bar slips from the handle during the jacking procedure.
- Do not get under a vehicle and no person should place any portion of their body under a vehicle that supported by a jack. Failure to observe this precaution could lead to an accident if the jack were to slip.
- If the underside of the vehicle is to be worked on after jacking up, jack stands must be used to support the vehicle.

**Operating the Jack****Raising the Vehicle**

1. Assemble the jack bars and jack handle.

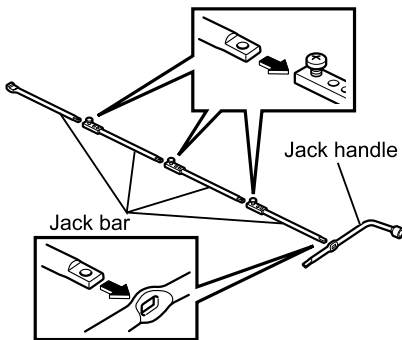

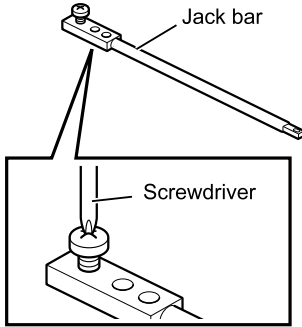

- When assemble jack bars to each other, tighten joint bolt by hand or a screwdriver (Phillips side). Make sure that the concave side is facing the bolt side of the other bar before tighten the bolt.

**CAUTION**

- Make sure that each screw joint is tightened properly.

- Insert the jack bar end into the jack socket.
- Place the jack immediately below the jacking point and ensure that it is upright. The jack must be placed on a flat, solid surface.
- Turn the jack handle, and check that the jack moves correctly.

Front Wheel Jacking Points

→ Refer to page 6-78

Rear Wheel Jacking Points

→ Refer to page 6-78

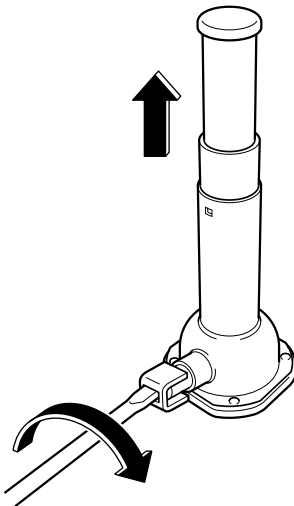

- Raise the vehicle by turning the jack handle clockwise.
- Confirm that the jack is in good contact with the jacking point, and then continue to raise the vehicle.

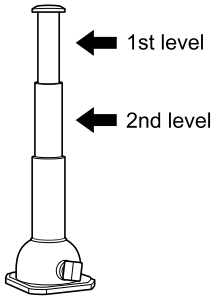
**⚠ WARNING**

- The jack has 2 levels. After completion of the 2nd level lifting, the handle becomes heavy to operate. At this time, stop lifting up with the jack. If lifting up is continued, the jack may be damaged. If the vehicle is lifted up with the jack excessively, the vehicle becomes unstable and very dangerous.

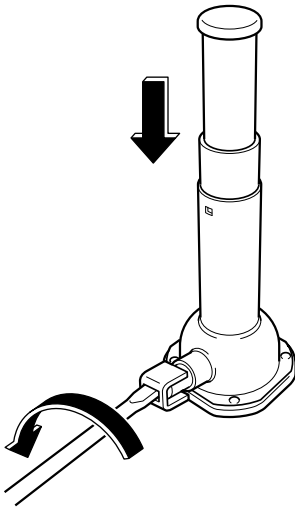
**Lowering the Vehicle**

Lower the vehicle by turning the jack handle counterclockwise to the ground.

Jacking Points

WARNING

- Failure to position the jack as described could result in serious personal injury or vehicle damage caused by the vehicle slipping off the jack.

Front Wheel Jacking Points

Apply the jack head to the flat part of the bracket on the frame side.

Rear Wheel Jacking Points

Set the jack at a point within 90 mm (3.5 in) from the leaf spring under the axle tube. Align the recess on the jack head to the curved surface of the axle tube center.

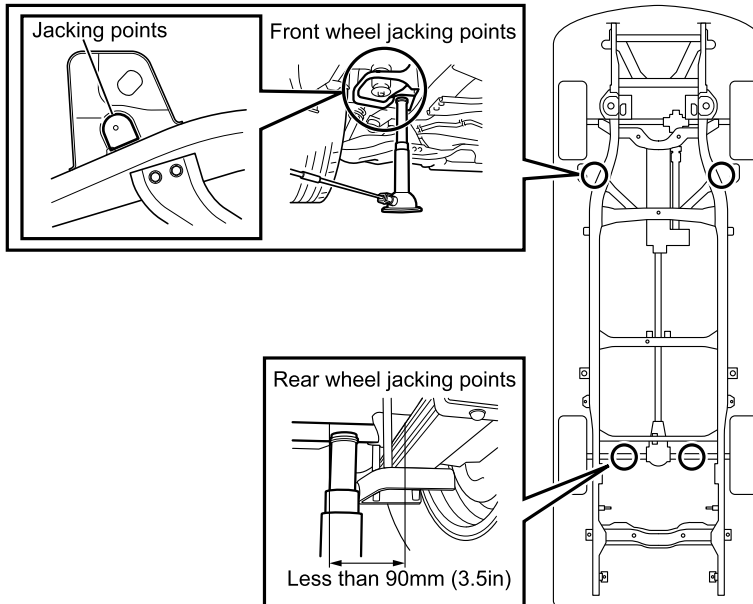

Changing Tires

Preparation

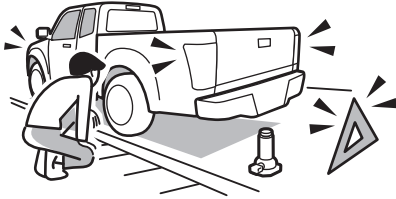

When you park the vehicle to change tires, choose a place listed below.

- Your vehicle does not hinder other traffic.
- The surface is level, flat and solid.
- You can change a tire safely.

When changing tires on a road, use the hazard warning flasher and triangle reflectors to alert other traffic to the presence of your vehicle.

Fully pull the parking brake lever, put the gearshift lever in the "R (reverse)" position for manual transmission models or put the selector lever in the "P" position for automatic transmission models. Chock both the front and back sides of the wheel diagonally opposite to the one to be changed with chocks (or stones, wood blocks, etc.). (Example: When changing the right rear wheel, chock the left front wheel.) Have the passengers get out of the vehicle.



CAUTION

- Use a tire of the specified size and the same tread pattern as the one to be replaced.

Removing a Wheel

 **WARNING**

- Always apply the parking brake fully and put the gearshift lever in the "R (reverse)" position for manual transmission models or put the selector lever in the "P" position for automatic transmission models and correctly chock the wheels before raising the vehicle. Applying only the parking brake is insufficient to prevent the vehicle from moving. When a rear wheel is jacked up, the vehicle blocked only by the parking brake would move, creating a very dangerous situation.
- Ensure that there are no people or objects present in the vehicle before it is jacked up.
- Never open doors or start the engine while jacking up the wheel. Do not try to look into the underside of the vehicle or get beneath the vehicle. This is very dangerous.
- To avoid danger in case of the jack slipping off, place the removed spare tire near the jack under the vehicle.
- Never apply oil or grease to the wheel bolts or nuts. Wheel nuts may loosen, causing the wheels to fall off and cause serious accidents.
- Never use heat to loosen tight wheel nuts. The application of heat to the hub can shorten the life of the wheel and may cause damage to wheel bearings.

 **CAUTION**

- The wheel is heavy. Carefully handle it to avoid getting hurt when removing and installing the wheel.
- Do not touch the engine, diesel particulate defuser (DPD), muffler, and exhaust pipe just after stopping the vehicle as they are very hot.
- Be careful for personal injuries when handling wheel ornaments.

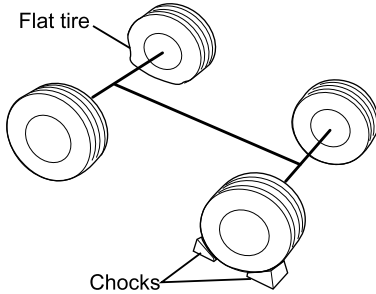

1. Firmly apply the parking brake and put the gearshift lever in the "R (reverse)" position for manual transmission models or put the selector lever in the "P" position for automatic transmission models. When changing a front wheel, chock the rear wheel diagonally opposite to the front wheel. When changing a rear wheel, chock the front wheel diagonally opposite to the rear wheel.
2. Firmly apply the head of the jack to the jacking point.

Handling the Jack

→ Refer to page 6-74

3. Raise the vehicle enough so that the tire not quite clear of the ground.

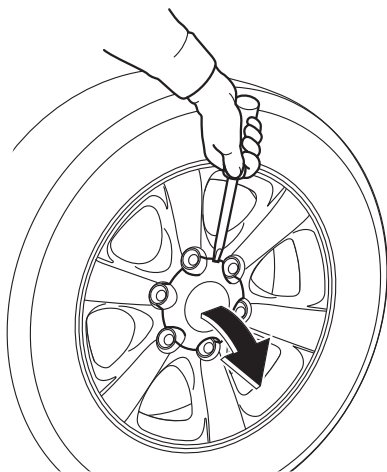
**Models with aluminum wheels
(except for 18-inch)**

4. For models with aluminum wheels (except for 18-inch), remove the wheel cover using a flat-head screwdriver or flat end of the jack handle. Insert the driver or the jack handle into the hole and pry the wheel cover off.

**CAUTION**

- Attempting to remove the wheel cover with bare hands could result in an injury caused by the edge of the wheel cover.

**ADVICE**

- Wrap a piece of cloth or tape around the flat-head screwdriver or the flat end of the jack handle so as not to damage the wheel and wheel cover.

- Using the wheel nut wrench, loosen the wheel nuts just enough so that the wheel remains stable in position. Do not remove the wheel nuts yet.

**CAUTION**

- Do not loosen the wheel nuts too much. The wheel bolts would be damaged.

- Jack up the vehicle so that the tire is clear of the ground completely.
- Remove all the wheel nuts that have been loosened, and then remove the wheel.

**ADVICE**

- Remove the wheel being careful not to damage the threads of the wheel bolts.
- Do not put the wheel with its design (outer) side down on the floor. It may cause scratch on the wheel surface.

- For models with 18-inch aluminum wheels, remove the wheel cover by pressing the wheel cover from the back side of the wheel.
- Check the following parts: the disc wheel for deformation and damage such as cracks; the hub for excessive wear of the disc wheel fitting surface; and the wheel bolts and nuts for damage to the threads. If anything abnormal is found in the above parts, check other parts as well, and replace any defective part with a new one.

Front Wheel Jacking Points

→ Refer to page 6-78

Rear Wheel Jacking Points

→ Refer to page 6-78

Installing a Wheel

WARNING

- A disc wheel, wheel bolts or wheel nuts in any abnormal condition could break later, causing the wheel to be detached from the vehicle while driving.
- If you find anything abnormal with wheel bolts, wheel nuts or disc wheels when you check them, avoid driving the vehicle and contact the nearest Isuzu Dealer.
- Do not repaint any mating surfaces, wheel nut seating surfaces (tapered surfaces) and hub fitting surface of the disc wheel. Thick paint films would cause loosened or broken wheel bolts.
- Do not assemble the wheel in a slanted state or with the center of the wheel misaligned state.
- Never apply oil or grease to the wheel bolts or nuts. By applying them, nuts may become over-tightened and cause damage to the bolts. Wheel nuts or bolts may loosen, causing the wheels to fall off and cause serious accidents. If oil or grease is found on any bolt or nut, clean it off.

CAUTION

- Change wheels only when the tire is clear of the ground. Otherwise, the wheel will be installed improperly and the operation of the vehicle will be affected adversely.
- Remove mud and rust from the hub fitting surface or wheel-to-wheel mating surfaces. Otherwise, the wheel might become loose while driving.

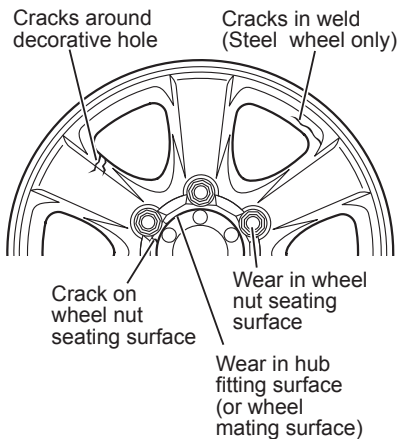

1. Check the disc wheel for the following:

- Cracks or other damage around the bolt holes and decorative holes
- Cracks or other damage or wear on the wheel nut seating surfaces (tapered surfaces)
- Cracks or other damage on welds (steel wheel only)
- Wear or other damage on the hub fitting surface or wheel-to-wheel mating surface

If you find anything abnormal with disc wheels when you check them, avoid driving the vehicle and contact the nearest Isuzu Dealer.

2. Check the wheel bolts and wheel nuts for the following:

- Cracks or other damage
- Bolt elongation or excessive rust
- Crushed, thinned or seized threads

If you find anything abnormal with wheel bolts or wheel nuts when you check them, avoid driving the vehicle and contact the nearest Isuzu Dealer.

**CAUTION**

- Remove rust and dirt from a wheel bolt and nut, and turn the nut on the bolt. If the nut does not turn smoothly, the threads are defective.
- If the threads are defective, replace both wheel bolt and wheel nut as a set.
- If any wheel bolt is broken, change all the wheel bolts and wheel nuts on the wheel.

3. Remove rust, dust and mud from the fitting surface, hub fitting surface or wheel-to-wheel mating surfaces, and wheel nut seating surfaces (tapered surfaces) of the disc wheel, and from the threads of the wheel bolts and nuts.

**CAUTION**

- Clean the disc wheel to remove dirt and rust from its fitting surfaces, hub fitting surface or wheel-to-wheel mating surface. Also clean the tapered portion of each nut. If you fasten the wheel nuts without removing dirt and rust, the wheel nuts would later loosen and the wheel might be detached from the vehicle while driving. This could be very dangerous.

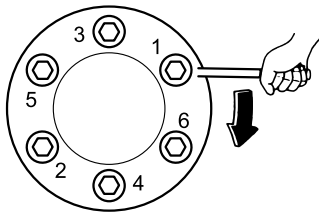
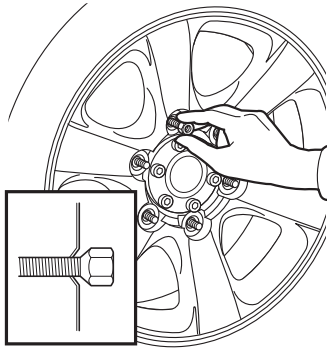

4. For models with 18-inch aluminum wheels, install the wheel cover by tapping the wheel cover into place with your hand after aligning the protrusions on the rear side of the wheel cover with the depressions on the wheel.
5. Install the wheel while aligning the bolt holes in the disc wheel with the wheel bolts.
6. Screw in each wheel nut by hand until it touches the nut seating surface on the disc wheel, and then finger tighten all wheel nuts until the wheel is held in position without any looseness. Face the tapered end of wheel nuts inward.
7. Turn the bleeder screw of the jack counterclockwise to lower the vehicle slowly.
8. Tighten the wheel nuts in a diagonal sequence and in two or three passes.

CAUTION

- Some impact wrenches available in the market produce torques higher than the maximum torque specified for tightening the wheel nuts. If the wheel nuts are tightened with such an impact wrench, wheel bolts might be broken. Before using an impact wrench, check that the torque it produces conforms to the specification.
- When using an impact wrench, carefully adjust the air pressure regulator and select the tightening time. As a final step, tighten to the specified torque using a torque wrench.

9. Finally, tighten all wheel nuts using a torque wrench to the specified torque.

Tightening torque

120 N·m (12 kgf·m/87 lb·ft)

Models with aluminum wheels (except for 18-inch)

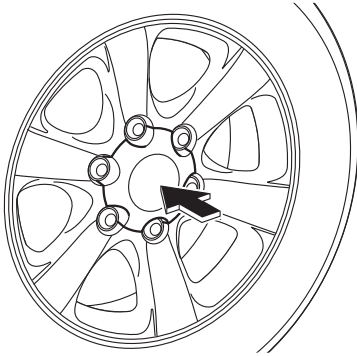

Models with 17-inch aluminum wheels

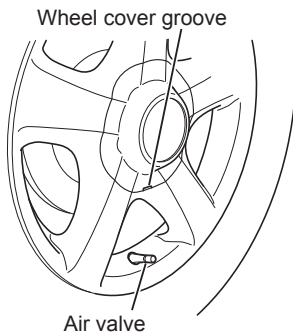

10. For models with aluminum wheels (except for 18-inch), install the wheel cover by tapping the wheel cover into place with your hand.
- For models with 17-inch aluminum wheels, align the wheel cover groove and the air valve when installing the wheel cover.
 - For models other than those with 17-inch aluminum wheels, align the protrusions on the rear side of the wheel cover with the depressions on the wheel when installing the wheel cover.



WARNING

- Do not attach plastic wheel ornaments that are heavily damaged. These may fly off from the wheels of your vehicle and cause accidents when the vehicle is driven.
- Make sure to secure all tools, jacks and flat tires into their storage locations before driving in order to reduce the possibilities of personal injury due to a collision or sudden braking.

**ADVICE**

- After changing a tire, turn the steering wheel in both directions to make sure that the wheels do not interfere with the surrounding components. If you are unclear about any of this, please contact the nearest Isuzu Dealer.
- The tightening torque of the wheel nuts may decrease after tire replacement due to their initial settlement. Upon driving 50 to 100 km (31 to 62 miles) after a tire change, retighten the wheel nuts to the specified torque according to the instructions in the "Retightening Wheel Nuts" section in this chapter.

Retightening Wheel Nuts

→ Refer to page 6-89

Retightening Wheel Nuts

Check the wheel nuts to make sure they are tightened to the specific torque by using a torque wrench.

Use the following methods to check loose wheel nuts. The tightening torque of the wheel nuts may decrease after a tire change or rotation due to their initial settlement. After driving 50 to 100 km (31 to 62 miles), be sure to retighten the wheel nuts to the specified torque.

Tightening torque

120 N·m (12 kgf·m/87 lb·ft)

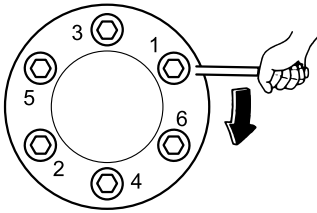

Turn the wheel nuts in the tightening direction to the specified torque.

WARNING

- If you find any abnormal conditions with the wheel nuts such as frequent loosening of retightened nuts, have your vehicle checked or serviced at the nearest Isuzu Dealer as soon as possible.

CAUTION

- Fully engage the wheel wrench on a wheel nut in order to tighten the nut to the specified torque. However, do not use a pipe as a handle extension or your foot to apply force on the wrench. This would tighten the nut more than required and might damage components.
- Both under-tightening and over-tightening of wheel nuts may cause broken wheel bolts or cracked disc wheels and could lead to wheel detachment. Adhere to the specified tightening torques.
- When replacing a tire with a new one, use only a tire of the same type and size as the replaced tire; otherwise, driving safety could be affected. Avoid mixed use of different types or different size tires at all costs.

Clutch (Manual Transmission Model)**Clutch Fluid**

The tank of the clutch fluid is common with a tank of the brake fluid.

⚠ WARNING

- If the clutch fluid gets in your eyes, rinse it off immediately with a large amount of water for 15 minutes or longer. Also, if still abnormality such as irritation is felt, seek medical attention.

⚠ CAUTION

- Before refilling the tank, clean the area around the cap and fill clutch fluid from a clean container. Foreign objects getting in the tank will lead to a clutch system failure.
- Be careful not to let clutch fluid come in contact with skin. If fluid comes into contact with skin, wash away the fluid with water.
- Clutch fluid melts paintwork and vehicle component materials such as plastic, vinyl and rubber. It is also highly corrosive on metals. If it is spilled, immediately wipe the area clean or wash away the fluid with water.
- If skin irritation persists, check with a doctor.
- Use only the specified clutch fluid and change it according to the Maintenance Schedule.
- Clutch fluid readily absorbs moisture. Close the cap of the container tightly when storing it.
- Do not mix clutch fluid with fluids of a non-specified brand. Due to chemical reactions, any mixture of differently branded fluids will cause failure of the clutch system.
- If clutch fluid decreases too rapidly, there might be a problem in the clutch system or the brake system, or the brake pads or shoe linings may have worn out. Have your vehicle inspected by the nearest Isuzu Dealer immediately.

Maintenance Schedule

→ Refer to page 6-122

Recommended Fluids, Lubricants and

Diesel Fuels → Refer to page 6-130

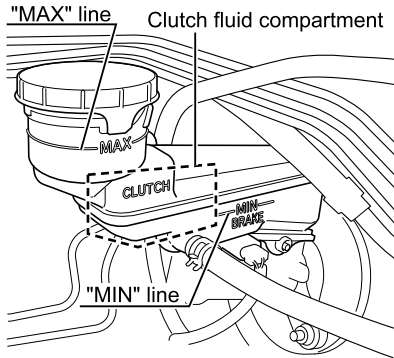

Checking the Clutch-Fluid Level

Confirm that the fluid level in the reserve tank is between the "MAX" and "MIN" lines. Be sure to use the clutch fluid compartment section when checking the "MIN" line section of the clutch fluid level. The clutch fluid level cannot be accurately checked if the clutch fluid level is checked with a method other than the clutch fluid compartment section.

If the fluid surface cannot easily be seen, rock the vehicle gently.

Adding Clutch Fluid

If the level of clutch fluid has dropped below the "MIN" line, remove the clutch fluid tank cap and add fluid. Add the specified clutch fluid up to the "MAX" line.

Changing Clutch Fluid

Change the clutch fluid according to the Maintenance Schedule using the specified fluid. Since a clutch fluid change requires disassembly of the related components, have this service performed by your Isuzu Dealer.

Automatic Transmission Fluid (Automatic Transmission Model)

Have inspection and replacement of the automatic transmission fluid performed at an Isuzu Dealer.

Steering Wheel

Checking the Steering Wheel

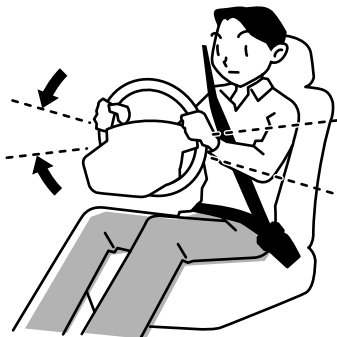

While the engine is idling, place the steering wheel in the straight forward position, then gently turn it to the left and right by hand, and check the play in the steering wheel as the peripheral distance to the point where the tires start moving.

Standard value
(at the periphery of the steering wheel)

10 - 30 mm (0.39 - 1.18 in)



Grasp the steering wheel with both hands, and move it in the axial direction and also up and down, and left and right to see if there is any looseness.

Also, drive the vehicle and check for abnormal shaking of the steering wheel, steering pull, sluggish steering, or inability to return to the straight forward position.

**CAUTION**

- If the steering parts have excess play or looseness or if any abnormal condition is noted, have the steering system checked at the nearest Isuzu Dealer immediately.

Power Steering Fluid

The power steering fluid level must be checked and it must be changed according to the Maintenance Schedule.

Have replacement of the power steering fluid performed at an Isuzu Dealer.

Maintenance Schedule

→ Refer to page 6-122

Checking the Power Steering Fluid Level

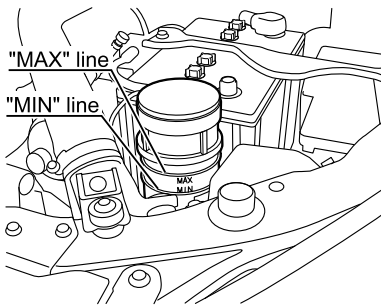

The reserve tank is located at the front of the engine compartment on the left. The fluid level is correct if it is between the "MAX" and "MIN" lines on the reserve tank. If the level is lower than the "MIN" line, add power steering fluid up to the "MAX" line. Furthermore, perform an inspection for power steering fluid leaks.

Engine Hood → Refer to page 6-10

Adding Power Steering Fluid



CAUTION

- Before adding fluid, clean the area around the cap and pour fluid from a clean jug or filler. Foreign matter getting in the tank will cause power steering system failure.
- Do not mix the recommended power steering fluid with fluids of other brands. Due to chemical reactions, any mixture of differently branded fluids will cause failure of the system.

Remove the reserve tank cap, and add power steering fluid up to the "MAX" line.



OTHER SERVICE AND MAINTENANCE

• Windshield Washer Fluid	6-96
• Windshield Wiper Blades	6-97
• Headlights and Turn Signal Lights	6-100
• Handling the Battery	6-101
• Refrigerant	6-112

Windshield Washer Fluid

Windshield Wiper/Washer

Check the level of fluid in the windshield washer tank. In addition, spray windshield washer fluid and operate the windshield wipers to check for any areas that are not being properly wiped. At this time, also check the spraying condition of the washer fluid.

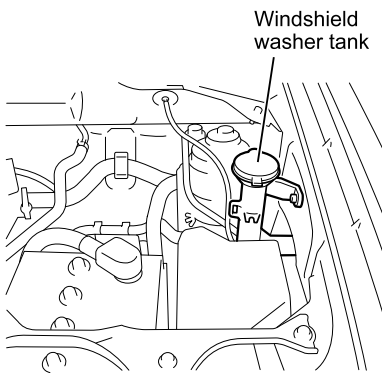

Refilling Windshield Washer Fluid

1. The windshield washer tank is located at the rear of the engine compartment on the left.
2. Open the cap and fill the tank with windshield washer fluid to the opening.



ADVICE

- Upon factory shipment, new vehicles contain only tap water in the washer fluid tank. Adjust the concentration of the fluid to suit your own usage.
- Follow the instructions provided with the windshield washer fluid regarding the ratio for mixing with tap water.
- Poor quality products, engine coolant, and soapy water must not be used. Failure to observe this precaution can result in nozzle blockage or damage to painted surfaces.
- The washer should never be used while the tank is empty. Operating the washer with the tank empty can result in motor damage.

Windshield Wiper Blades

Daily Checks

Spray windshield washer fluid and then operate the windshield wipers to check for any poorly wiped areas. In addition, confirm that the functions operate normally.

Windshield Wiper Blade Replacement

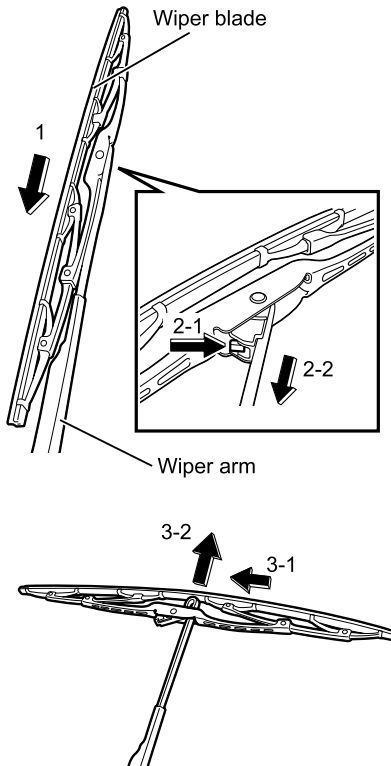

Removal

1. Pull the wiper arm up to the vertical position.
2. While pressing the wiper blade hook towards the arm, slide the blade downwards (towards the base of the arm).
3. With the blade and arm almost perpendicular, remove the blade from the arm.

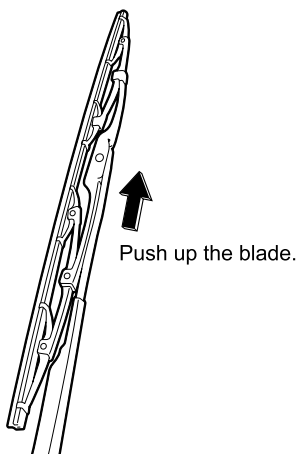
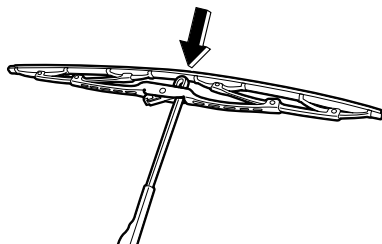

Installation

1. Insert the blade while holding it almost perpendicular to the arm.
2. Then, with the blade and arm oriented in the same direction, push up the blade until it locks into place on the arm.



ADVICE

- Do not lower the wiper arm with its blade removed; the windshield glass may be scratched.
- Whenever a wiper blade has been attached, ensure that it is locked into place. Failure to observe this precaution can result in the wiper blade becoming dislocated when the windshield wiper switch is turned on.

Replacement of Wiper Rubber Insert**Removal**

1. Remove the wiper blade from the wiper arm.
2. Pull the wiper rubber insert in the direction indicated by the arrow and extract it from the wiper blade.

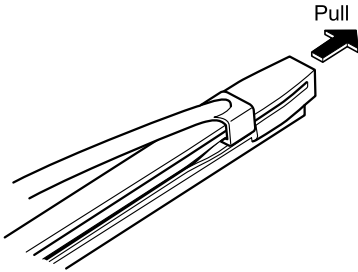
**Installation**

1. Insert a new wiper rubber insert into the wiper blade.

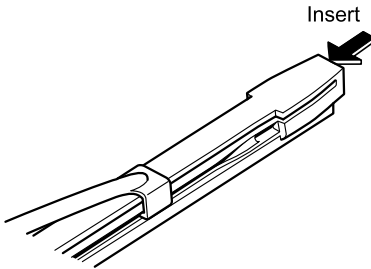

2. Continue pushing in the wiper rubber insert until the wiper blade's hook engages with the hole in it, and then confirm that the rubber insert is securely held in place.
3. Attach the wiper blade to the wiper arm.

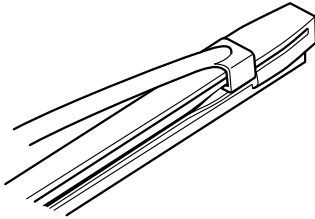

Headlights and Turn Signal Lights

Switch the power mode to "ON" (models with passive entry and start system) or turn the starter switch to the "ON" position (models without passive entry and start system), and then check the way in which the headlights, turn signal lights, and other exterior lights come on and flash.

In addition, depress the brake pedal to confirm whether the stop lights come on, and shift the transmission to "R" position to confirm whether the back up lights come on. Also examine the lights for discoloration, damage, and looseness.

When the Bulb Does not Come On
 → Refer to page 7-34

Front

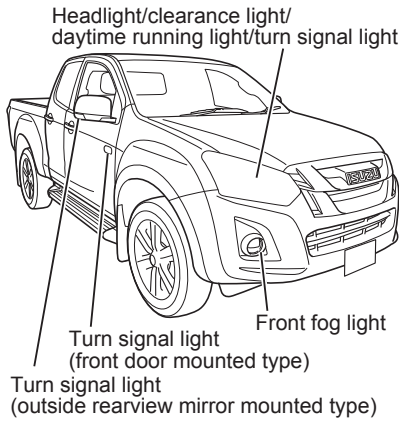

Rear

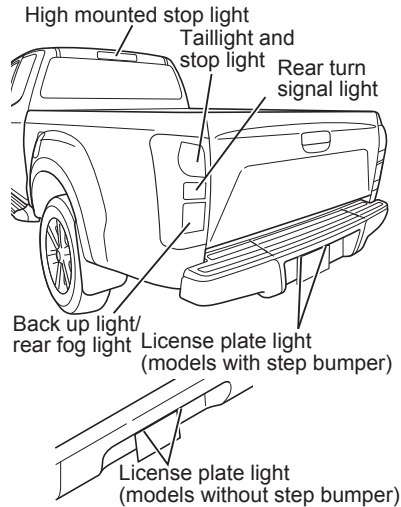

Rear (Horizontal type)

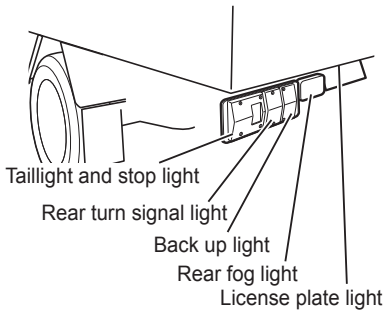

Handling the Battery



DANGER

- Usage or charging of the battery when the battery fluid is below the lower level line can accelerate deterioration and give rise to dangerous situations such as the generation of heat and even explosion.
- If battery fluid should come in contact with an eye, immediately wash it out using a large amount of water and continue washing for at least 5 minutes. Following this, contact a doctor for a medical examination. If fluid adheres to any part of the body, wash it off using a large amount of water and contact a doctor for a medical examination.
- When using tools or other metal objects in the vicinity of the battery, take care to prevent them from coming into contact with the positive terminal. As the vehicle itself will conduct electricity, any such contact can result in a short-circuit and a highly dangerous electric shock.
- A vehicle battery generates extremely flammable hydrogen gas. For this reason, operations producing sparks or requiring the usage of an open flame must never be carried out near a vehicle battery. Failure to observe this precaution can result in explosion if the hydrogen gas ignites. Whenever wiping up battery fluid, a damp cloth should be used.



WARNING

- Always stop the engine whenever the battery is to be inspected.
- Dilute sulfuric acid is used as the battery fluid. Wear protective goggles when handling the battery. Special care must be taken to ensure that this fluid does not come into contact with skin, clothing, or the vehicle body.
- Battery fluid should never be filled beyond the upper level line. Failure to observe this precaution can result in battery fluid spillage and corrosion of battery terminals and other components. Any spilled battery fluid should be immediately washed away with water.
- Do not allow your face or head to come close to the battery except when absolutely necessary.

WARNING (Continued)

WARNING (Continued)

- When disconnecting cables, switch the power mode to "OFF" (models with passive entry and start system) or turn the starter switch to the "LOCK" position (models without passive entry and start system), wait at least 1 minute, and then disconnect the cables starting with the negative cable from the terminals. If the negative cable is disconnected within 1 minute, the engine control module may malfunction. When reconnecting them, the negative cable should be reconnected last.
- Be careful not to inhale the hydrogen gas that emits from the battery.
- Recharge the battery in a well-ventilated area. Do not recharge the battery in an enclosed room, etc.
- Wash your hands after handling battery posts, terminals and related accessories.
- Be sure to keep the battery away from children.

**ADVICE**

- Whenever battery fluid has been added, the battery should be recharged (by driving the vehicle). In winter months in particular, battery fluid can freeze and damage the battery case if you fail to recharge the battery.
- If the battery fluid level continues to drop at an unusually fast rate, have an inspection carried out immediately by the nearest Isuzu Dealer.

Battery Handling Precautions

Keep the battery clean. If the battery is left in a dirty condition, contaminants can get mixed into the battery fluid, the battery plates can be damaged, short circuits can occur on the top surface of the battery and the battery's service life can be reduced.

Models with passive entry and start system

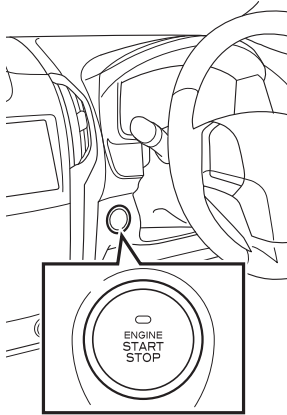

Models without passive entry and start system

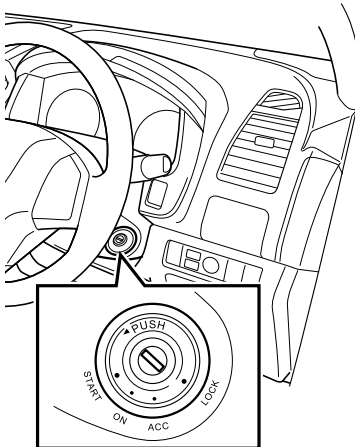

When Performing Inspection or Maintenance

Before starting inspection and maintenance of the battery or other parts of the electrical system, switch the power mode to "OFF" (models with passive entry and start system) or turn the starter switch to the "LOCK" position (models without passive entry and start system), wait at least 1 minute, and then disconnect the negative cable from the negative terminal. If the negative cable is disconnected within 1 minute, the engine control module may malfunction.

There is a danger that electrical components could be damaged if inspection or maintenance is carried out if the battery remains connected.

Engine Start/Stop Button (Models with Passive Entry and Start System)

→ Refer to page 4-116

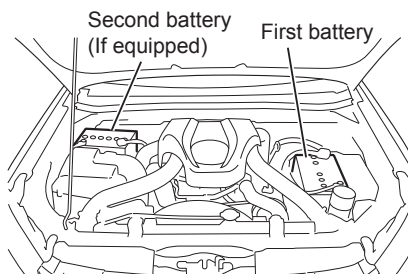

Battery Installation Position

Depending on the vehicle model, there may be one battery (first battery) or two batteries (first and second battery).

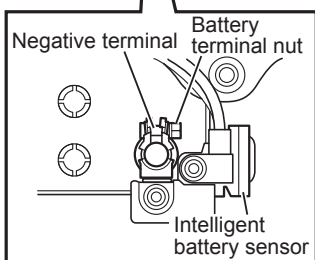
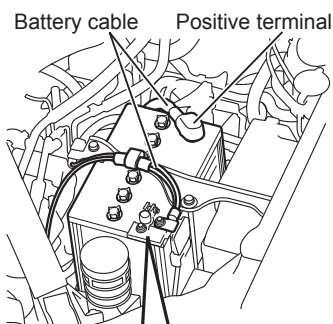

Removing the Battery

When the battery is to be removed, switch the power mode to "OFF" (models with passive entry and start system) or turn the starter switch to the "LOCK" position (models without passive entry and start system), wait at least 1 minute, and then disconnect the cables starting with the negative cable from the terminals.

WARNING

- If the battery cable remains connected to the negative terminal, any contact made by tools and the like between the positive terminal and the vehicle body could lead to a short-circuit and dangerous electrical shocks. The electrical system can also be damaged.
- Do not tilt the battery.

CAUTION

- If the negative cable is disconnected from the negative terminal on the battery within 1 minute after switching the power mode to "OFF" (models with passive entry and start system) or turning the starter switch to the "LOCK" position (models without passive entry and start system), the engine control module may malfunction.

**ADVICE**

- When removing the negative terminal, loosen the battery terminal nut and remove the intelligent battery sensor while keeping the cable attached. (Do not loosen any nuts other than the battery terminal nut.)

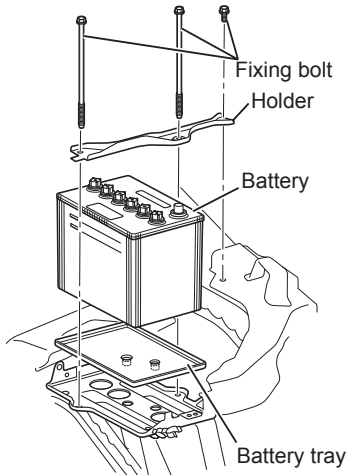
First battery

1. Switch the power mode to "OFF" (models with passive entry and start system) or turn the starter switch to the "LOCK" position (models without passive entry and start system), wait at least 1 minute, and then disconnect the negative cable from the negative terminal.
2. Disconnect the positive cable from the positive terminal.
3. Remove the fixing bolts and holder that secure the battery in place.
4. Remove the battery.

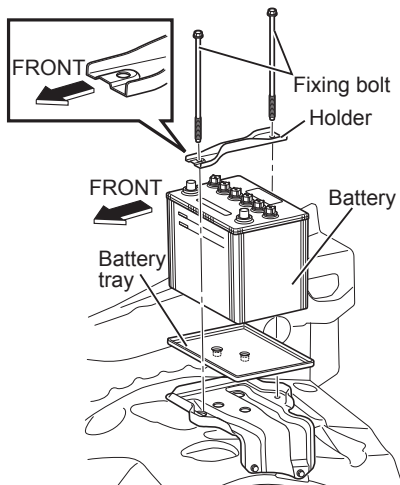
Second battery

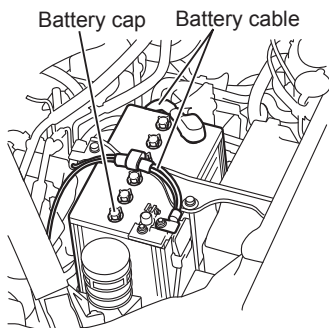

Charging the Battery

1. Before charging the battery, remove it from the vehicle to a location with good ventilation and take off the battery caps. If, on the other hand, the battery is to be charged while still on the vehicle, be sure to first disconnect the battery cables.
2. Whenever a charger is being connected to or disconnected from a battery, ensure that it is turned off.
3. Battery cables must always be disconnected when performing quick charging.
Failure to observe this precaution can result in generator burnout.

DANGER

- Do not use open flames in the vicinity of the battery when it is being charged. Hydrogen gas is generated by the battery during the charging process; accordingly, failure to observe this precaution can result in fire or explosion.

Installing the Battery

When connecting the battery cables, start with the positive terminal and then connect the negative terminal. When installing the negative terminal, install with the battery and terminal aligned side-by-side (as shown in the diagram). After installing, check that the intelligent battery sensor is not in contact with any surrounding parts.

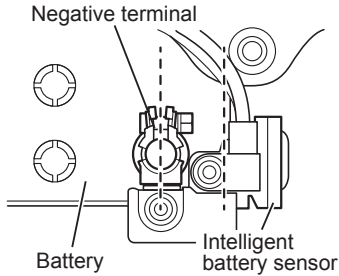

CAUTION

- Take care to avoid mixing up the positive and negative terminals when connecting battery cables. Incorrect connection to these terminals can result in flow of excessive current and burnout of the generator or vehicle wiring.
- In models with passive entry and start system, the power mode cannot be switched when the battery has been removed. The power mode that was being used before the battery was removed is stored in the passive entry and start system, so if the battery is reconnected, the power mode may be set to "ON". When the battery is to be removed, switch the power mode to "OFF", wait at least 1 minute, and then remove the battery.



ADVICE

- When installing the battery in your vehicle, ensure that it is oriented correctly and securely fastened without any looseness. If the battery is not installed correctly, the battery case and battery plates can be damaged as a result of vibrations during driving.

**NOTE**

- In models with passive entry and start system or keyless entry system (radio remote control units for door-lock), the map light and dome light may not illuminate if the battery terminal is connected with a door open. If this occurs, the lights can be illuminated by closing the doors once or by switching the power mode to "OFF" (models with passive entry and start system) or turning the starter switch to "LOCK" position from the "ACC" or "ON" position (models with keyless entry system).
- The electronic stability control (ESC) warning light may turn on when the battery cables are disconnected or the battery voltage is low. The ESC function turns off while the ESC warning light is on, but the ESC warning light will turn off by driving the vehicle normally for a while, then the ESC function will resume. If the ESC warning light remains on even after driving for a while, contact the nearest Isuzu Dealer.

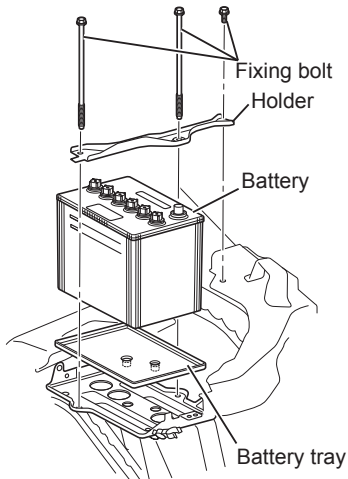
First battery

1. Install the battery tray.
2. Install the battery. Ensure that the battery is oriented correctly and placed so as to be seated correctly without any looseness.
3. Install the holder and fixing bolts.
4. Connect the positive cable to the positive terminal.
5. Connect the negative cable to the negative terminal.

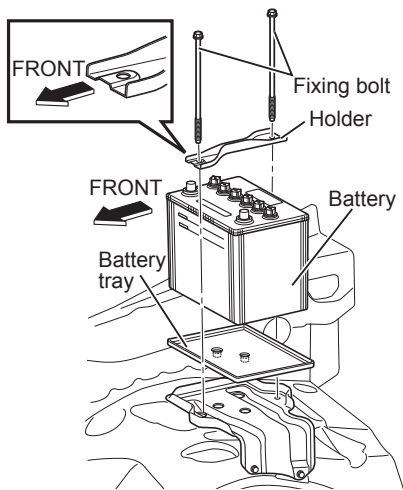
Second battery**Using the Battery as a Direct Power Source**

The battery should not be used as a direct source of 12 V power.

If your battery must be used as a direct power source, please consult with your Isuzu Dealer.

Checking the Battery Fluid Level

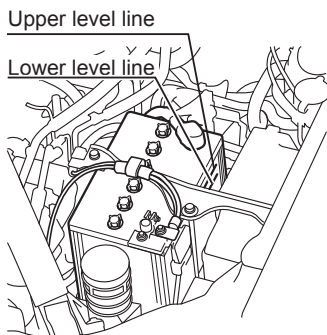

Daily Check

Confirm whether the level of fluid inside the battery case is within the specified range.

The surface of the battery fluid should be between the upper level and lower level lines. If the surface of the fluid cannot easily be seen, rock the vehicle gently.

Filling Battery Fluid

If the battery fluid level is below the lower level line, remove the cap and add distilled water up to the upper level line. After refilling, firmly attach the cap.



WARNING

- Battery fluid should never be filled beyond the upper level line. Failure to observe this precaution can result in battery fluid spillage and corrosion of battery terminals and other components. Any spilled battery fluid should be immediately washed away with water.



ADVICE

- Whenever battery fluid has been added, the battery should be recharged (by driving the vehicle). In winter months in particular, battery fluid can freeze and damage the battery case if you fail to recharge the battery.
- If the battery fluid level continues to drop at an unusually fast rate, have an inspection carried out immediately by the nearest Isuzu Dealer.

Checking the Specific Gravity of Battery Fluid

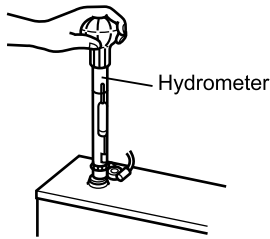

1. Check the specific gravity of the battery fluid using a hydrometer. If the specific gravity is too low, the battery should be charged.

Specific gravity at a fluid temperature of
20°C (68°F)

1.27 - 1.29

Checking the Battery Terminals



1. Check the terminals for looseness, cracks and corrosion. If there are cracks at the terminal, have inspection and replacement performed at an Isuzu Dealer.
2. If a terminal is found to be corroded and coated in white powder, wash this away with warm water and then wipe fully dry. Excessively corroded terminals should be polished using a wire brush or sandpaper.
3. When you have finished cleaning the terminals, apply a thin layer of grease and securely connect the battery cables, taking care to ensure that they are tight.
See "When the Battery Goes Flat" regarding steps to be taken should the battery be completely discharged.

When the Battery Goes Flat

→ Refer to page 7-26

Refrigerant

The air conditioning system will not be able to cool the cab interior effectively if the refrigerant level is low. Accordingly, the refrigerant level must be topped up whenever necessary.

Please contact your Isuzu Dealer whenever refrigerant must be added.



ADVICE

- Operating the air conditioning while the refrigerant level is too low leads not only to poor cooling performance but also to air conditioning system damage.
- This vehicle uses the new refrigerant HFC-134a (R-134a) in the air conditioning system. No other type of refrigerant can be used. In order to protect the environment, care must be taken to ensure that refrigerant gas is never released into open air. When refrigerant must be replaced, therefore, please contact your Isuzu Dealer or other service facility equipped with a gas recovery installation system.



NOTE

[Refrigerant]

- Type: HFC-134a (R-134a)
- Global Warming Potential (GWP): 1430

INTERIOR AND EXTERIOR MAINTENANCE

• Exterior Maintenance	6-114
• Interior Maintenance	6-117

Exterior Maintenance

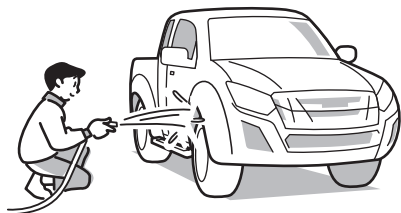

Washing

If the vehicle is operated with foreign material adhering to the exterior, this material may react chemically with paint or plating, resulting in staining, discoloration, rusting or corrosion of components. Also, the material may become trapped within mechanical components, adversely affecting their functions or forming an aerodynamic resistance. In the following cases, therefore, the vehicle must be washed and all foreign matter removed.

- When soot, iron powder, dead bugs, bird droppings, pollen, tree sap or oily matter from coal tar and smoke has adhered to painted surfaces.
 - When the vehicle has been driven in coastal areas.
 - When the vehicle has been driven on roads where road chemicals have been applied.
 - When a large amount of mud or dirt has adhered to the exterior.
1. Fully turn on the tap, and wash out the undercarriage and suspension.
 2. Close all openings and wash the cab and cargo body panels using a neutral detergent.
 3. Clean wheels and tires using a brush and detergent.
 4. After washing away all remaining detergent, use a shammy or other clean cloth to fully remove all moisture and water droplets.

**WARNING**

- When cleaning the bottom of the vehicle or chassis, be careful so as to prevent burns and injuries. The area around the engine, diesel particulate defuser (DPD), muffler, and exhaust pipe are extremely hot immediately after vehicle operation, so wait until the vehicle has cooled down before cleaning. Otherwise, you could be burned.

**CAUTION**

- Do not apply water directly in order to clean the cab interior. Failure to observe this precaution can result in malfunction or breakdown of electronic control units and electrical components, or in rusting of the cab floor.
- Do not apply water from a high-pressure washer nozzle directly to the electric connectors. Failure to observe this precaution can lead to faulty operation of the electrical system.

**ADVICE**

- Do not use solvents, gasoline, kerosene, benzene, or thinner, etc., to clean the vehicle exterior.
- If an automatic car wash is used with vehicles having dark or metallic coating, the painted surfaces can be damaged by the brushes, lose their luster or be very noticeably scratched.
- Do not direct a large amount of water at the air inlet openings.
- Do not apply water to the engine compartment or at electrical components. Failure to observe this precaution can lead to a poorly starting and operating engine and problems in the electrical system.
- Ensure that mirrors and the antenna are retracted before washing the vehicle.
- If an automatic car wash must be used, avoid a high-temperature, high-pressure type machine. Failure to observe this precaution can lead to heat deformation and breakage of plastic components, or to water leaks into the cab.
- When using an automatic car wash, ensure that a distance of at least 0.4 m (15.75 in) is maintained between the nozzle and the vehicle, and when washing door windows, that the spray is perpendicular to the surface of the glass.
- Ensure that all detergent is fully washed and wiped away. Particularly in the case of strong alkaline detergents (typically those for industrial uses), there is a danger that hairline cracks can develop in lighting-cluster lenses if the vehicle is operated without detergent being fully wiped away. Always read the detergent manufacturer's instructions carefully before use.

ADVICE (Continued)

ADVICE (Continued)

- Airborne dirt that adheres to plastic front bumpers as a result of rain, for example, can be difficult to remove. In such a case, use a commercially-available cleaner to clean away the dirt, and then apply a wax for use with plastic components.

Vehicle Storage

In order to maintain your vehicle's attractive appearance for as long as possible, special consideration must be given to its storage location.

If the vehicle is stored or kept for an extended period of time in any of the following locations, a chemical change may occur in the paintwork, resulting in staining, discoloration, rusting, and corrosion of components.

- Locations where a large amount of oily matter, soot, heavy smoke or metal powder can adhere to the vehicle.
- Areas around pharmaceutical plants and other facilities that discharge chemical matter.
- Coastal areas
- Locations where a large amount of dead bugs, bird droppings or tree sap can adhere to the vehicle.

Waxing

Painted and chrome-plated surfaces should be waxed once or twice a month, or whenever water is being poorly repelled on the surfaces. Ensure that wax is not applied in direct sunlight, and that the temperature of the painted surface is no more than 40°C (104°F).

Always follow the instructions provided with your wax product.

**CAUTION**

- Wax must not be applied to the windshield. Failure to observe this precaution can result in irregular reflection of light, impairing your view.

**ADVICE**

- Do not use wax containing abrasive material. Failure to observe this precaution can lead to scratching of painted surfaces or plastic components.
- The application of wax to rubber component surfaces can result in permanent whitening.



Windshield Care

If not fully cleaned by the windshield wipers, the windshield should be cleaned using Isuzu genuine glass cleaner.

Interior Maintenance

Remove dust and dirt from the interior of the cab using an automotive cleaner or vacuum cleaner, and gently wipe surfaces clean using a cloth wet with warm or cold water.

WARNING

- When cleaning the interior of the cab, water should never be sprayed directly. Failure to observe this precaution can lead to vehicle malfunction and possibly to fire if water should enter the audio system or other electrical components located underneath the floor carpet.
- Do not use organic solvents such as petroleum ether and gasoline or abrasive cleaners to clean the seat belts.
In addition, seat belt webbing should be neither bleached nor redyed. Failure to observe these precautions can lead to the performance or strength of the seat belts being impaired. In the case of a collision, therefore, the belts could be insufficiently effective, and serious life-threatening injuries could result. When cleaning, use warm water in which a small amount of neutral detergent has been dissolved to gently wipe the seat belts.
- Keep the seat belts in a clean, dry condition.

**CAUTION**

- Do not use organic solvents such as mineral oil, benzine, thinner, or gasoline, nor acid or alkaline solvents or fatty acid ester. Failure to observe this precaution can result in discoloration, staining, or damage. It should be noted that certain types of cleaning products contain these compounds. Be sure to read cleaning product labels carefully.
- Do not let perfume, cosmetics or air fresheners (liquid, solid, gel or plate types) direct come into contact with or spill onto interior components such as the air conditioning or audio system. Compounds contained in these products can cause discoloration, staining, peeling of paint, or damage.
- Glass cleaners that contain these compounds must not be used to clean the inside of the windshield or window glass. To clean the glass, wipe using a cloth wet with warm or cold water.
- For models with a rear defogger, when cleaning the interior of the backlight glass, lightly wipe along the defogger wires using a wet cloth to avoid disconnecting the rear defogger. Use of glass cleaner, etc. may cause the defogger to become inoperative.

**ADVICE**

- Do not apply a silicon-based spray to electrical components such as the audio system or switches. It may cause faults with the points of contact.

Seat Belt Care

A dirty seat belt can develop retracting problems, and for this reason, regular inspection and upkeep are required.



CAUTION

- Seat belt webbing can lose its strength when bleached or redyed, or when cleaned using gasoline, paint thinners or other volatile substances.
- Do not disassemble the seat belt mechanism in order to remove any foreign material or objects that may have entered the buckle. Instead, arrange for inspection and maintenance to be carried out by your Isuzu Dealer.

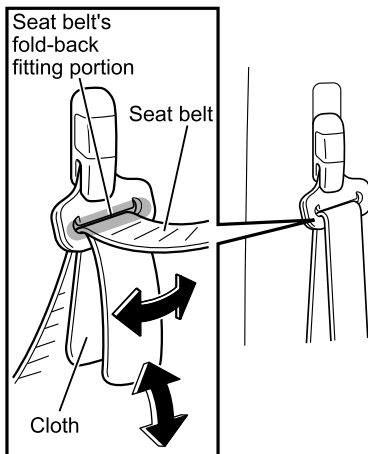

Cleaning a Seat Belt's Fold-back Fitting Portion

1. Fold a piece of cotton cloth, absorbent gauze, or the like of approximately 50 mm (2 in) in width into a rectangle.
2. Mix one part neutral detergent into approximately twenty parts warm water.
3. Wet the cloth in the detergent mixture, pass it through the fold-back fitting portion of the belt, and slide it back and forth and laterally until dirt can no longer be seen.
4. Remove the cloth, remove moisture from the fitting portion of the belt using a dry cloth, and then allow it to dry naturally out of direct sunlight.
5. Check to be sure the seat belt retracts and pulls out correctly.



ADVICE

- Avoid using anything like a tool to pass the cloth through the fold-back fitting portion or try to remove stubborn dirt. Using such an object can result in plastic parts or seat belt webbing damage.

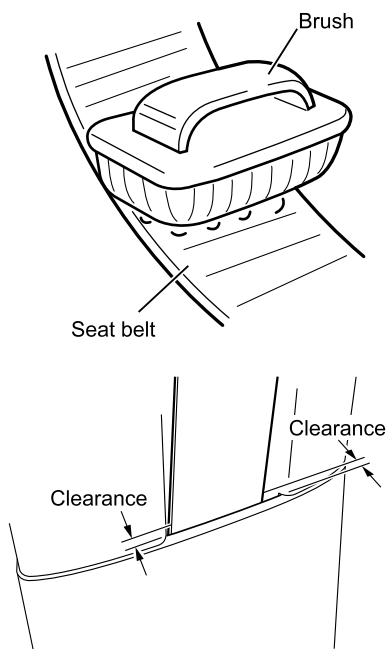

Cleaning a Belt Webbing

1. Fully extract the belt and examine for any difference in color between the front and back surfaces.
2. Mix one part neutral detergent into approximately twenty parts warm water.
3. Wet a nail brush or another similar brush having soft bristles (of nylon or the like) in warm water, and use this to clean away dirt.
4. Wipe the seat belt dry using a dry cloth, and then allow it to dry naturally out of direct sunlight.
5. Check to be sure the seat belt retracts and pulls out correctly.



ADVICE

- If the above-described upkeep operations do not improve the operation of the seat belt through the retractor, there is a possibility that the belt is making contact with the door pillar trim. In this case, arrange for inspection and maintenance to be carried out by your Isuzu Dealer.
- If the belt is not winding and unwinding correctly, or if inspection reveals problems such as loose mountings, metal parts deformation, webbing damage, fraying or discoloration, arrange for replacement to be carried out by your Isuzu Dealer.

Fabric Seat Covering and Carpet Care

Remove dirt and dust using a home-use electric vacuum cleaner.

Do not remove the carpet. Use standard household cleaning products and methods to remove stains from food, drink and the like.

Be sure to use neutral detergents or cleaning products indicated as higher alcohol based detergents.

MAINTENANCE DATA

• Inspection and Maintenance

6-122

Inspection and Maintenance

For safe and economic driving, be sure to have your vehicle inspected and serviced regularly according to the schedule indicated in this chapter.

Maintenance Schedule

To drive your vehicle safely and at minimum cost, it is essential to have your vehicle regularly inspected and serviced at your Isuzu Dealer as per the specified maintenance schedule.

Contact your Isuzu Dealer for inspection that requires disassembly and/or special equipment.

Letters Used to Indicate Maintenance Service Types

I : Inspect then clean, repair or replace as necessary

A: Adjust

R: Replace

T: Tighten to the specified torque

L: Lubricate



ADVICE

- When inspecting the items listed below, also inspect the routine inspection items as well.

*: Your vehicle needs to be maintained more often if it is driven in severe conditions.

Maintenance Schedule for Severe-condition Operations

→ Refer to page 6-129

Maintenance Schedule: TFR/S 86 (4JK1-TCY HIHI-POWER)

I : Inspect then clean, repair or replace as necessary A: Adjust R: Replace
T: Tighten to the specified torque L: Lubricate

Service item	Service content	Service interval (Odometer reading or months, whichever comes first)	Reference page
* Engine oil	R	Every 20,000 km (12,000 miles) or 24 months	6-20
* Engine oil filter	R	Every 20,000 km (12,000 miles) or 24 months	6-26
Engine oil leakage and contamination	I	Every 20,000 km (12,000 miles) or 24 months	6-20
Engine idling speed and acceleration	I	Every 20,000 km (12,000 miles) or 24 months	6-19
Fan belt tension and damage	I	Every 20,000 km (12,000 miles) or 24 months	6-47
Exhaust system	I	Every 20,000 km (12,000 miles) or 24 months	—
All hoses and pipes in engine compartment for clog or damage	I	Every 20,000 km (12,000 miles) or 24 months	—
Valve clearance	I	Every 40,000 km (24,000 miles) or 48 months	—
* Air cleaner element	I R	Every 20,000 km (12,000 miles) or 24 months Every 40,000 km (24,000 miles) or 48 months	6-50
Fuel filter	R	Replace the fuel filter when the fuel filter warning light comes on	4-86 6-53
Fuel tank	I	Every 20,000 km (12,000 miles) or 24 months	—
Fuel hoses and pipes for clog or damage	I	Every 20,000 km (12,000 miles) or 24 months	—
Draining of water separator	Drain the fuel filter when the water separator warning light comes on		4-85 6-53
Engine coolant concentration	I	Every 20,000 km (12,000 miles) or 24 months	6-41
Engine coolant	R	Every 40,000 km (24,000 miles) or 24 months (when Isuzu recommended coolant is used)	6-40
Cooling system for water leakage	I	Every 20,000 km (12,000 miles) or 24 months	6-43
Clutch fluid	I R	Every 20,000 km (12,000 miles) or 24 months Every 40,000 km (24,000 miles) or 48 months	6-90
Clutch pedal travel and play	I	Every 20,000 km (12,000 miles) or 24 months	—
* [M/T] Manual transmission oil	I	Every 20,000 km (12,000 miles) or 24 months	—
* [M/T] Transfer case oil	I	Every 20,000 km (12,000 miles) or 24 months	—
[M/T] Manual transmission and transfer case oil leakage	I	Every 20,000 km (12,000 miles) or 24 months	—
Gear control mechanism for looseness	I	Every 20,000 km (12,000 miles) or 24 months	—

* Marks: Under severe driving conditions, additional maintenance is required.
Refer to "Maintenance Schedule for Severe-condition Operations".

Service item	Service content	Service interval (Odometer reading or months, whichever comes first)	Reference page
* [A/T] Automatic transmission fluid	I	Every 100,000 km (60,000 miles) or 60 months	6-91
* [A/T] Transfer case oil	I	Every 20,000 km (12,000 miles) or 24 months	—
[A/T] Automatic transmission fluid and transfer case oil leakage	I	Every 20,000 km (12,000 miles) or 24 months	—
Propeller shaft loose connections	I	Every 10,000 km (6,000 miles) or 12 months	—
* Propeller shaft universal joints and splines for wear	I	Every 10,000 km (6,000 miles) or 12 months	—
[4WD] Propeller shaft universal joints and sliding sleeve	L	Every 10,000 km (6,000 miles) or 12 months	—
* Differential gear oil (Front and rear)	R I R	Initial 10,000 km (6,000 miles) or 12 months Every 20,000 km (12,000 miles) or 24 months Every 40,000 km (24,000 miles) or 48 months	—
Front and rear axle oil leakage	I	Every 20,000 km (12,000 miles) or 24 months	—
Shift on the fly system gear oil	I	Every 20,000 km (12,000 miles) or 24 months	—
Front axle shaft rubber boot for damage	I	Every 20,000 km (12,000 miles) or 24 months	—
Axle case for distortion or damage	I	Every 20,000 km (12,000 miles) or 24 months	—
Axle shafts for distortion or damage	I	Every 20,000 km (12,000 miles) or 24 months	—
Power steering fluid	I R	Every 20,000 km (12,000 miles) or 24 months Every 80,000 km (48,000 miles) or 96 months	6-93
Power steering fluid leakage	I	Every 20,000 km (12,000 miles) or 24 months	6-93
* Steering system for looseness or damage	I	Every 20,000 km (12,000 miles) or 24 months	—
Power steering hose	I R	Every 20,000 km (12,000 miles) or 24 months Every 100,000 km (60,000 miles) or 120 months	—
Steering wheel play	I	Every 20,000 km (12,000 miles) or 24 months	6-92
Steering function	I	Every 20,000 km (12,000 miles) or 24 months	—
Right and left turning radius	I	Every 20,000 km (12,000 miles) or 24 months	—
Wheel alignment	I	Every 20,000 km (12,000 miles) or 24 months	—
Steering joint ball for oil leakage or damage	I	Every 20,000 km (12,000 miles) or 24 months	—
Steering joint ball rubber boot for damage	I	Every 20,000 km (12,000 miles) or 24 months	—
Brake fluid	I R	Every 20,000 km (12,000 miles) or 24 months Every 40,000 km (24,000 miles) or 48 months	6-58

* Marks: Under severe driving conditions, additional maintenance is required.
Refer to "Maintenance Schedule for Severe-condition Operations".

Service item	Service content	Service interval (Odometer reading or months, whichever comes first)	Reference page
Brake system for fluid leakage	I	Every 10,000 km (6,000 miles) or 12 months	—
Brake function	I	Every 10,000 km (6,000 miles) or 12 months	—
* Front disc brake pad and disc wear	I	Every 10,000 km (6,000 miles) or 12 months	—
* Rear brake lining and drum wear	I	Every 10,000 km (6,000 miles) or 12 months	—
Brake pedal travel and play	I	Every 10,000 km (6,000 miles) or 12 months	6-60
Brake pipes and hoses for loose connections or damage	I	Every 10,000 km (6,000 miles) or 12 months	—
Parking brake function	I	Every 10,000 km (6,000 miles) or 12 months	—
Parking brake lever travel	I	Every 10,000 km (6,000 miles) or 12 months	6-63
Parking brake cables for looseness or damage and guide for damage	I	Every 20,000 km (12,000 miles) or 24 months	—
Parking brake ratchet for wear or damage	I	Every 10,000 km (6,000 miles) or 12 months	—
Leaf/coil springs for damage	I	Every 20,000 km (12,000 miles) or 24 months	—
Suspension mount for looseness or damage	I	Every 20,000 km (12,000 miles) or 24 months	—
Shock absorbers for oil leakage	I	Every 20,000 km (12,000 miles) or 24 months	—
Shock absorbers mount for looseness	I	Every 20,000 km (12,000 miles) or 24 months	—
Rubber bushes of suspension wear or damage	I	Every 20,000 km (12,000 miles) or 24 months	—
Spring action for loss of balance due to weakening	I	Every 20,000 km (12,000 miles) or 24 months	—
Suspension joint ball rubber boot for damage	I	Every 20,000 km (12,000 miles) or 24 months	—
Wheel nuts	T	Every 10,000 km (6,000 miles) or 12 months	6-89
Wheel disc for damage	I	Every 20,000 km (12,000 miles) or 24 months	6-67 6-84
Front hub bearing grease	R	Every 30,000 km (18,000 miles) or 36 months	—
Front and rear hub bearing for looseness	I	Every 10,000 km (6,000 miles) or 12 months	—
Tire air pressure and damage	I	Every 20,000 km (12,000 miles) or 24 months	6-64 6-66
Tire rotation		Rotate as required	6-69
Other bolts and nuts on chassis and body	I	Every 20,000 km (12,000 miles) or 24 months	—
Air conditioning filter	R	Every 20,000 km (12,000 miles) or 24 months	—

* Marks: Under severe driving conditions, additional maintenance is required.
Refer to "Maintenance Schedule for Severe-condition Operations".

Maintenance Schedule: TFR/S 87 (RZ4E-TCX HI-POWER)

I : Inspect then clean, repair or replace as necessary A: Adjust R: Replace
T: Tighten to the specified torque L: Lubricate

Service item	Service content	Service interval (Odometer reading or months, whichever comes first)	Reference page
* Engine oil	R	Every 20,000 km (12,000 miles) or 24 months	6-20
* Engine oil filter	R	Every 20,000 km (12,000 miles) or 24 months	6-30
Engine oil leakage and contamination	I	Every 20,000 km (12,000 miles) or 24 months	6-20
Engine idling speed and acceleration	I	Every 20,000 km (12,000 miles) or 24 months	6-19
Accessory belt tension and damage	I	Every 20,000 km (12,000 miles) or 24 months	6-47
Exhaust system	I	Every 20,000 km (12,000 miles) or 24 months	—
All hoses and pipes in engine compartment for clog or damage	I	Every 20,000 km (12,000 miles) or 24 months	—
* Air cleaner element	I R	Every 20,000 km (12,000 miles) or 24 months Every 40,000 km (24,000 miles) or 48 months	6-50
Fuel filter	R	Replace the fuel filter when the fuel filter warning light comes on	4-86 6-53
Fuel tank	I	Every 20,000 km (12,000 miles) or 24 months	—
Fuel hoses and pipes for clog or damage	I	Every 20,000 km (12,000 miles) or 24 months	—
Draining of water separator	Drain the fuel filter when the water separator warning light comes on		4-85 6-53
Engine coolant concentration	I	Every 20,000 km (12,000 miles) or 24 months	6-41
Engine coolant	R	Every 40,000 km (24,000 miles) or 24 months (when Isuzu recommended coolant is used)	6-40
Cooling system for water leakage	I	Every 20,000 km (12,000 miles) or 24 months	6-43
Clutch fluid	I R	Every 20,000 km (12,000 miles) or 24 months Every 40,000 km (24,000 miles) or 48 months	6-90
Clutch pedal travel and play	I	Every 20,000 km (12,000 miles) or 24 months	—
* [M/T] Manual transmission oil	I R	Every 20,000 km (12,000 miles) or 24 months Every 40,000 km (24,000 miles) or 48 months	—
* [M/T] Transfer case oil	I	Every 20,000 km (12,000 miles) or 24 months	—
[M/T] Manual transmission and transfer case oil leakage	I	Every 20,000 km (12,000 miles) or 24 months	—
Gear control mechanism for looseness	I	Every 20,000 km (12,000 miles) or 24 months	—
* [A/T] Automatic transmission fluid	I	Every 100,000 km (60,000 miles) or 60 months	6-91

* Marks: Under severe driving conditions, additional maintenance is required.
Refer to "Maintenance Schedule for Severe-condition Operations".

Service item	Service content	Service interval (Odometer reading or months, whichever comes first)	Reference page
* [A/T] Transfer case oil	I	Every 20,000 km (12,000 miles) or 24 months	—
[A/T] Automatic transmission fluid and transfer case oil leakage	I	Every 20,000 km (12,000 miles) or 24 months	—
Propeller shaft loose connections	I	Every 10,000 km (6,000 miles) or 12 months	—
* Propeller shaft universal joints and splines for wear	I	Every 10,000 km (6,000 miles) or 12 months	—
[4WD] Propeller shaft universal joints and sliding sleeve	L	Every 10,000 km (6,000 miles) or 12 months	—
* Differential gear oil (Front and rear)	R I R	Initial 10,000 km (6,000 miles) or 12 months Every 20,000 km (12,000 miles) or 24 months Every 40,000 km (24,000 miles) or 48 months	—
Front and rear axle oil leakage	I	Every 20,000 km (12,000 miles) or 24 months	—
Shift on the fly system gear oil	I	Every 20,000 km (12,000 miles) or 24 months	—
Front axle shaft rubber boot for damage	I	Every 20,000 km (12,000 miles) or 24 months	—
Axle case for distortion or damage	I	Every 20,000 km (12,000 miles) or 24 months	—
Axle shafts for distortion or damage	I	Every 20,000 km (12,000 miles) or 24 months	—
Power steering fluid	I R	Every 20,000 km (12,000 miles) or 24 months Every 80,000 km (48,000 miles) or 96 months	6-93
Power steering fluid leakage	I	Every 20,000 km (12,000 miles) or 24 months	6-93
* Steering system for looseness or damage	I	Every 20,000 km (12,000 miles) or 24 months	—
Power steering hose	I R	Every 20,000 km (12,000 miles) or 24 months Every 100,000 km (60,000 miles) or 120 months	—
Steering wheel play	I	Every 20,000 km (12,000 miles) or 24 months	6-92
Steering function	I	Every 20,000 km (12,000 miles) or 24 months	—
Right and left turning radius	I	Every 20,000 km (12,000 miles) or 24 months	—
Wheel alignment	I	Every 20,000 km (12,000 miles) or 24 months	—
Steering joint ball for oil leakage or damage	I	Every 20,000 km (12,000 miles) or 24 months	—
Steering joint ball rubber boot for damage	I	Every 20,000 km (12,000 miles) or 24 months	—
Brake fluid	I R	Every 20,000 km (12,000 miles) or 24 months Every 40,000 km (24,000 miles) or 48 months	6-58
Brake system for fluid leakage	I	Every 10,000 km (6,000 miles) or 12 months	—

* Marks: Under severe driving conditions, additional maintenance is required.
Refer to "Maintenance Schedule for Severe-condition Operations".

Service item	Service content	Service interval (Odometer reading or months, whichever comes first)	Reference page
Brake function	I	Every 10,000 km (6,000 miles) or 12 months	—
* Front disc brake pad and disc wear	I	Every 10,000 km (6,000 miles) or 12 months	—
* Rear brake lining and drum wear	I	Every 10,000 km (6,000 miles) or 12 months	—
Brake pedal travel and play	I	Every 10,000 km (6,000 miles) or 12 months	6-60
Brake pipes and hoses for loose connections or damage	I	Every 10,000 km (6,000 miles) or 12 months	—
Parking brake function	I	Every 10,000 km (6,000 miles) or 12 months	—
Parking brake lever travel	I	Every 10,000 km (6,000 miles) or 12 months	6-63
Parking brake cables for looseness or damage and guide for damage	I	Every 20,000 km (12,000 miles) or 24 months	—
Parking brake ratchet for wear or damage	I	Every 10,000 km (6,000 miles) or 12 months	—
Leaf/coil springs for damage	I	Every 20,000 km (12,000 miles) or 24 months	—
Suspension mount for looseness or damage	I	Every 20,000 km (12,000 miles) or 24 months	—
Shock absorbers for oil leakage	I	Every 20,000 km (12,000 miles) or 24 months	—
Shock absorbers mount for looseness	I	Every 20,000 km (12,000 miles) or 24 months	—
Rubber bushes of suspension wear or damage	I	Every 20,000 km (12,000 miles) or 24 months	—
Spring action for loss of balance due to weakening	I	Every 20,000 km (12,000 miles) or 24 months	—
Suspension joint ball rubber boot for damage	I	Every 20,000 km (12,000 miles) or 24 months	—
Wheel nuts	T	Every 10,000 km (6,000 miles) or 12 months	6-89
Wheel disc for damage	I	Every 20,000 km (12,000 miles) or 24 months	6-67 6-84
Front hub bearing grease	R	Every 30,000 km (18,000 miles) or 36 months	—
Front and rear hub bearing for looseness	I	Every 10,000 km (6,000 miles) or 12 months	—
Tire air pressure and damage	I	Every 20,000 km (12,000 miles) or 24 months	6-64 6-66
Tire rotation		Rotate as required	6-69
Other bolts and nuts on chassis and body	I	Every 20,000 km (12,000 miles) or 24 months	—
Air conditioning filter	R	Every 20,000 km (12,000 miles) or 24 months	—

* Marks: Under severe driving conditions, additional maintenance is required.
Refer to "Maintenance Schedule for Severe-condition Operations".

Maintenance Schedule for Severe-condition Operations

Driving condition

A: Repeated short trips

B: Driving on rough roads

C: Driving on dusty roads

D: Driving in extremely cold weather and/or on salted roads

E: Towing trailer or climbing mountain frequently

F: Continuous driving in low speed and/or with a low load

G: Frequently turning the engine off during DPD regeneration

Service item	Service interval	Condition
Engine oil	4JK1 engine model: Replace every 5,000 km (3,000 miles)	C, F, G, A+D
	RZ4E engine model: Replace every 5,000 km (3,000 miles)	C, E, F, G, A+D
Engine oil filter	4JK1 engine model: Replace every 5,000 km (3,000 miles)	C, F, G, A+D
	RZ4E engine model: Replace every 10,000 km (6,000 miles)	C, E, F, G, A+D
Exhaust pipes and mounting	Inspect every 10,000 km (6,000 miles)	A, B, D
Air cleaner element	Inspect every 5,000 km (3,000 miles) Replace every 20,000 km (12,000 miles)	C
Steering system for looseness or damage	Inspect every 5,000 km (3,000 miles)	B
Universal joints and sleeves	Inspect for wear and lubricate every 5,000 km (3,000 miles)	B, C
Manual transmission oil	Replace every 20,000 km (12,000 miles) after replacing at initial 10,000 km (6,000 miles)	B
Automatic transmission fluid	Inspect every 40,000 km (24,000 miles) Replace every 80,000 km (48,000 miles)	B, E, A+D
Transfer case oil	Replace every 20,000 km (12,000 miles) after replacing at initial 10,000 km (6,000 miles)	B
Differential oil	Replace every 20,000 km (12,000 miles) after replacing at initial 10,000 km (6,000 miles)	B
Front brake pad and disc wear	Inspect every 5,000 km (3,000 miles)	A, B, C
Rear brake lining and drum wear	Inspect every 5,000 km (3,000 miles)	A, B, C

Recommended Fluids, Lubricants and Diesel Fuels

It is extremely important to select correct lubricants and diesel fuels so that your Isuzu vehicle demonstrates its full performance over the years. Top up the lubricants in accordance with the Maintenance Schedule specified for your vehicle. Use the Isuzu genuine lubricants or those recommended in the list below. Also, do not use additives other than those specified. The lubricant change intervals specified in the Maintenance Schedule and the terms and conditions of the new vehicle warranty assume the use of the Isuzu genuine or Isuzu recommended lubricants listed below.

LUBRICATION	GRADE			FOR EXAMPLE
	API	ACEA	JASO	
* Diesel engine crankcase (Low ash oil)	CI-4 CJ-4	E6 E9	DH-2	BESCO CLEAN (5W-30) (ISUZU) BESCO CLEAN (10W-30) (ISUZU) BESCO CLEAN SUPER (10W-40) (ISUZU) Vanellus Max Drain Eco (10W-40) (BP) Vanellus Multi Fleet Eco (15W-40) (BP) Tecthion Global ES (15W-40) (Castrol) Performance Harmony (15W-40) (Elf) Delvac XHP ESP (10W-40) (ExxonMobil) Delvac MX ESP (10W-30), (15W-40) (ExxonMobil) Delvac 1300 Super (10W-30), (15W-40) (ExxonMobil) Rimula R6 LM (10W-40) (Shell) Rubia TIR 7900 (15W-40) (Total) Rubia TIR 7900 FE (10W-30) (Total) Rubia Works 2000 (10W-40) (Total)
Manual transmission (Models with AY6)	GL-5 MT1	—	—	Multigear S (75W-90) (Chevron/Texaco/Caltex) JWS2250C (75W-90) (ExxonMobil)
Manual transmission (Models with MVL6N)	BESCO TRANSAXLE (5W-30) (ISUZU)			
Transfer case	CI-4	E7	DH-1	BESCO TRANSAXLE (5W-30) (ISUZU) Delo 400 Multigrade (15W-40) (Chevron/Texaco/Caltex) Performance Victory (15W-40) (Elf) Delvac MX (15W-40) (ExxonMobil) Rimula R4X (15W-40) (Shell) Rubia TIR 7400 (15W-40) (Total)
Automatic transmission (Models with TB-50LS)	ISUZU ATF WSI (ISUZU) Mobil ATF 3309 (ExxonMobil)			
Automatic transmission (Models with AWR6B45)	ISUZU ATF WSI (ISUZU)			
Front differential	GL-5 MT1	—	—	BESCO SHIFT ON THE FLY (75W-90) (ISUZU) Multigear S (75W-90) (Chevron/Texaco/Caltex) Mobil Delvac 1 Gear Oil (75W-90) (ExxonMobil)

*: We recommend you to use a low ash content engine oil that is suitably compatible with the DPD.

LUBRICATION	GRADE			FOR EXAMPLE
	API	ACEA	JASO	
Rear differential	GL-5 MT1	—	—	BESCO SHIFT ON THE FLY (75W-90) (ISUZU) BESCO GEAR SH (80W-90), (90), (140) (ISUZU) Syntrax Universal (80W-90) (Castrol) Thuban GL-5 EP (80W-90), (85W-140) (Chevron/Texaco/Caltex) Multigear S (75W-90) (Chevron/Texaco/Caltex) Gearleif 5 (80W-90), (85W-140) (Elf) Tranself Type B (80W-90), (85W-140) (Elf) Mobil Delvac 1 Gear Oil (75W-90) (ExxonMobil) Mobilube S (80W-90) (ExxonMobil) Spirax S2 A IZ (80W-90) (Shell) Spirax S3 AX (80W-90) (Shell) Transmission XPM (80W-90) (Total) Transmission TM (80W-90), (85W-140) (Total)



NOTE

- The factory filled SAE 5W-30 engine oil is optimal for fuel efficiency and low carbon dioxide (CO₂) emissions, as well as for low temperature starts.

Engine Oil and Gear Oil Viscosity Charts

→ Refer to page 6-134

LUBRICATION	GRADE
Power steering	BESCO ATF III (ISUZU) DEXRON® III or equivalent
Center bearing/ Kingpins	BESCO L2 GREASE (No.2), L3 GREASE (No.3) (ISUZU) NLGI #2 or #3 multi-purpose grease
Propeller shaft sliding yoke/ Universal joint	BESCO ONE LUBER Mo GREASE (No.2) (ISUZU) NLGI #2 multi-purpose grease containing molybdenum disulfide

COOLANT	GRADE	FOR EXAMPLE
Engine cooling system	GENERAL MOTORS ENGINEERING STANDARDS GM6277M (Ethylene glycol based non-amine, non-silicate and non-borate coolant) or equivalent.	BESCO LLC SUPER TYPE E (ISUZU) BESCO LLC SUPER TYPE AS (ISUZU) Havoline XLC (Artego) Glysantin G34 (BASF) Glacelf Auto Supra (Total) Coolelf Auto Supra 37 (Total)



ADVICE

- Mix the coolant and water at an appropriate concentration.
- Direct use of "50/50 Pre-diluted" product which is already diluted to 50% concentration is recommended.

Preparing Engine Coolant

→ Refer to page 6-41

FLUID	MAKE	BRAND	GRADE
Clutch and brake fluid reservoir	ISUZU AC Delco	BESCO BRAKE FLUID SUPER Supreme 11	DOT 3 (FMVSS 116 or SAE J1703)
	—	—	DOT 4 (FMVSS 116 or SAE J1704)

DIESEL FUEL / APPLICABLE STANDARD (Sulfur content below 10 ppm)

Deutsche Industrie Normen (DIN)

Based on EN590 : 2009

British Standards (BS)

Based on EN590 : 2009



WARNING

- Open the fuel tank filler cap slowly. If you open it quickly, the fuel tank pressure may cause fuel to spurt out.



CAUTION

- Be sure to use extra-low-sulfur diesel fuel (containing sulfur of 10 ppm or lower).
- If you supply the vehicle with poor-quality fuel, water-removal additive or other additive, gasoline, kerosene or alcohol-based fuel, it could harm the fuel filter, prevent proper movement of fuel-lubricated parts in the injectors and adversely affect engine components, possibly resulting in a breakdown. If you accidentally put the wrong fuel in the tank, drain it all out. Starting the engine with the wrong fuel in the tank could result in a fire and engine damage.



ADVICE

- Only use fuels listed above. Do not use other fuels as they may adversely affect the engine.

Refueling Using Fuels that Contain Biodiesel Fuel (Fatty Acid Methyl Esters (FAME))

Models for the European Market

- You can use standard type diesel fuels that meet EN590. A standard type diesel fuel means the fuel that contains biodiesel fuel (FAME) which meets EN14214.
- Using diesel fuels that do not meet EN590, or using fuels that contain FAME which does not meet EN14214 may, in the worst case, cause a serious engine failure.
- Do not leave the diesel fuel that contains FAME unused in the vehicle for a long period of time. FAME contents may block up the fuel system, causing a serious engine failure.
- The vehicle is covered under the vehicle warranty given if the fuel that meets EN590 is used. However, if the vehicle is left unused for a long period of time, the characteristics of the fuel may change, causing a vehicle failure. The vehicle warranty is not applicable in such cases.



NOTE

- When changing from 0% FAME diesel to the fuel that contains FAME which meets EN590, there may be a negative impact on performance when pulling away and driving in general.

Engine Oil and Gear Oil Viscosity Charts

Select appropriate engine and gear oils in accordance with the tables below. It is also important to select the viscosity appropriate for the temperature at which your vehicle operates. Use the following tables for making correct selections.

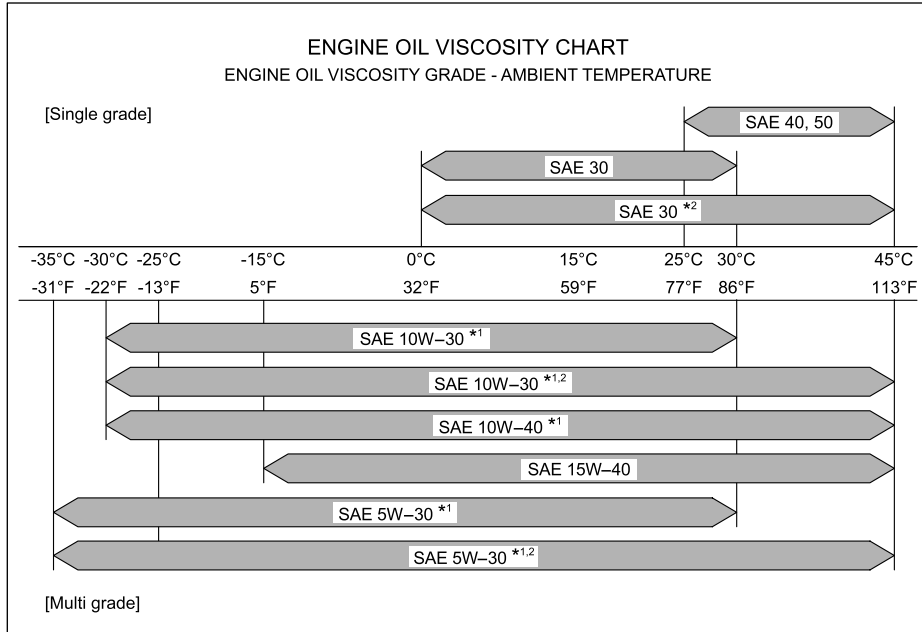

*1: At ambient temperatures below -25°C (-13°F), this can only be used when starting aids (oil pan heater, block heater, etc.) are used.

*2: Use is possible at ambient temperatures up to 45°C (113°F) only in the case of Isuzu genuine oil.



NOTE

- In extremely low temperatures, engine starts may be difficult when SAE 10W-30 or higher viscosity grade engine oils are used. Because of this, use of SAE 5W-30 engine oil is recommended.
- Higher viscosity grade engine oils may be better for when the vehicle is driven at high speeds or when it is under extreme load conditions.

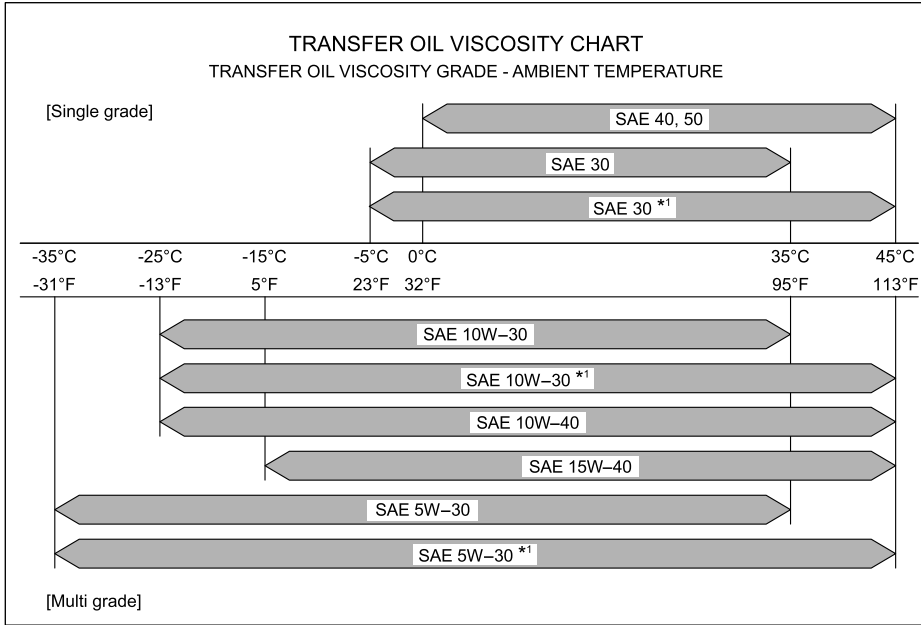

*1: Use is possible at ambient temperatures up to 45°C (113°F) only in the case of Isuzu genuine oil.

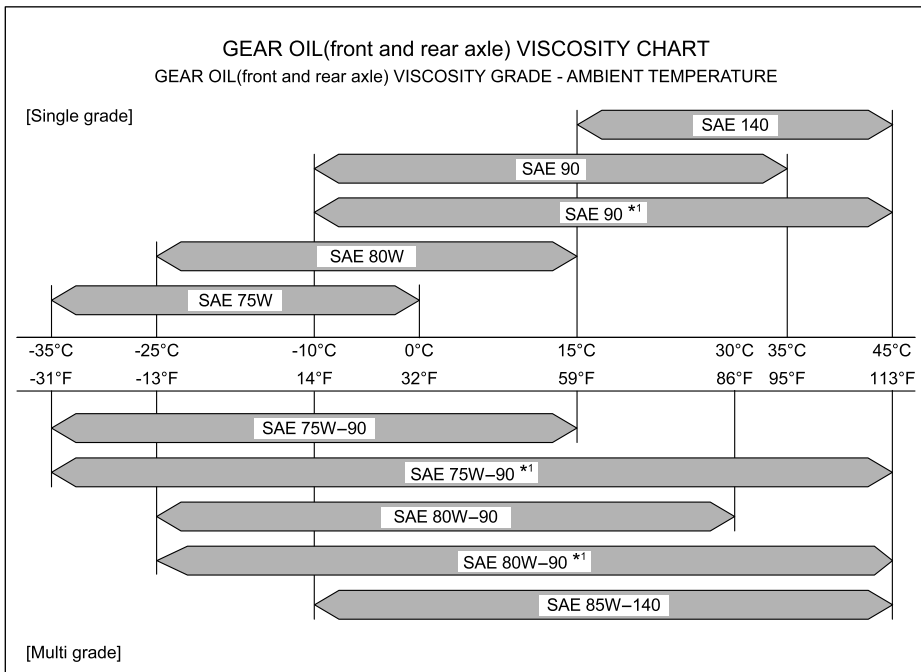

*1: Use is possible at ambient temperatures up to 45°C (113°F) only in the case of Isuzu genuine oil.

6-136

SERVICE AND MAINTENANCE



IN CASE OF EMERGENCY

7

• Troubleshooting	7-2
• When the Electronic Key Battery Goes Flat	7-7
• Emergency Engine Stopping (Models with Passive Entry and Start System)	7-10
• Emergency Engine Starting (Models with Passive Entry and Start System)	7-11
• When the Vehicle Breaks Down during Driving	7-12
• When the Tire Goes Flat	7-13
• When the Engine Stops While Driving	7-24
• When the Engine Stalls and Cannot be Restarted	7-25
• When the Brakes Do not Work	7-25
• When the Battery Goes Flat	7-26
• When the Fuel Runs Out	7-28
• When the Generator Warning Light Comes On	7-30
• When the Engine Oil Pressure Warning Light Comes On	7-31
• When the Warning Light Comes On	7-31
• When the Engine Overheats	7-32
• When the Bulb Does not Come On	7-34
• Replacing the Fuses and Relays	7-46
• When Driving on Bad Roads	7-56
• Towing	7-57

Troubleshooting

Performing regular inspections and maintenance prevents damage. Be sure to perform inspections and maintenance at regular intervals. Also, quickly rectify any fault in the vehicle (even a small fault) to prevent it from becoming more serious.

If a symptom shown in the following table occurs, perform inspections and take corrective action in accordance with the table. If you are unable to perform a repair, the corrective action shown in the table does not eliminate a symptom or you cannot locate a fault, contact the nearest Isuzu Dealer.



ADVICE

- Any item for which there is a © in the "Corrective action" column requires repairs and adjustments. Contact the nearest Isuzu Dealer.

Symptom		Cause	Corrective action	Reference page
Engine does not start	Starter does not turn over, or is weak	Flat batteries	Recharge or replace	7-26
		Battery terminals detached, loose or corroded	After repairing corroded section, connect the terminals firmly	6-111
		Starter ground wire terminal detached, loose or corroded	After repairing corroded section, connect the terminals firmly	—
		Engine oil viscosity too high	Change to oil with proper viscosity	6-134
		Starter or electrical system is faulty	⊙	—
		Selector lever is not in the "P" or "N" position (automatic transmission model)	Place selector lever in "P" or "N" position (automatic transmission model)	4-4 4-141
		Gearshift lever is not in the "N" position (manual transmission models with passive entry and start system)	Place the gearshift lever in the "N" position (manual transmission models with passive entry and start system)	4-4 4-138
		Brake pedal (automatic transmission models) or clutch pedal (manual transmission models) is not depressed (models with passive entry and start system)	Depress the brake pedal (automatic transmission models) or clutch pedal (manual transmission models) (models with passive entry and start system)	4-4 4-136
		Passive entry and start system is not verified	Check if electronic key is carried with you	4-4
			Replace the battery	3-17
	Passive entry and start system is faulty	⊙	—	
	Starter turns over	No fuel	Make sure there are no fuel leaks, and then add fuel	—
		Air in the fuel system	Bleed fuel system	7-29
		Fuel filter is clogged	⊙	—
		Fuel is frozen	Warm fuel pipe with hot water or wait until it gets warmer	—
		Common rail system is faulty	⊙	—
		Preheating system is faulty	⊙	—

7-4

IN CASE OF EMERGENCY

Symptom	Cause	Corrective action	Reference page
Starter takes a long time to turn over	Pre-heating is performed (models with passive entry and start system)	—	4-4
Engine starts, but immediately stops	Fuel filter is clogged	⊙	—
	Air cleaner is clogged	Clean or replace element	6-50
	Common rail system is faulty	⊙	—
Unsteady engine speed	There is water or air in the fuel system	Drain water from fuel filter or bleed fuel system	6-53 7-29
	Fuel system is faulty	⊙	—
White or black exhaust smoke	Engine not sufficiently warmed up	Allow engine to warm up sufficiently	—
	Excessive engine oil	Correct oil level	6-20
	Air cleaner is clogged	Clean or replace element	6-50
	Fuel system is faulty	⊙	—
	DPD is faulty	⊙	—
Engine is overheating	No or low engine coolant	Add engine coolant	6-40
	Front of radiator is clogged with dirt	Wash clean with tap water	6-45
	Radiator cap not sufficiently tightened	Refill the engine coolant and make sure the radiator cap is firmly tightened.	6-40
	Fan belt loose	Adjust the tension or replace the belt	6-47
	Engine coolant dirty	⊙	—
	Fan clutch is faulty	⊙	—
	Radiator cap dirty or faulty	⊙	—
Oil pressure is low	Improper engine oil viscosity	Change to oil with proper viscosity	6-134
	Engine oil level too low	Add engine oil	6-23
	Engine inner components are faulty	⊙	—
	Meter, indicator/warning lights or switches faulty	⊙	—

Symptom	Cause	Corrective action	Reference page
Not enough engine power	Parking brake not fully released	Make sure it is fully released	—
	Brake dragging	⊙	—
	Clutch slipping (manual transmission model)	⊙	—
	Air cleaner is clogged	Clean or replace element	6-50
	Fuel filter is clogged	⊙	—
	Engine control system faulty	⊙	—
	Common rail system faulty	⊙	—
	Engine faulty	⊙	—
	DPD clogged	⊙	—
Brakes not effective	Drum-to-lining gap too large	⊙	—
	Air in brake fluid	⊙	—
	Brake system failure	⊙	—
Uneven braking	Unbalanced air pressure in tires	Adjust to proper air pressure	6-64
	Tire unevenly worn	Replace tire	6-79
	Unbalanced drum-to-lining gap of the wheels	⊙	—
	Poor wheel alignment	⊙	—
Steering wheel hard to turn	Loaded too far forward	Load properly	2-6
	Power steering fluid level too low	Add fluid	6-93
	Insufficient air in front tires	Adjust to proper inflation pressure	6-64
Excessive play in the steering wheel	Wheel nuts loose	Tighten to the specified torque	6-89
	Unbalanced inflation pressure in the tires	Adjust to proper inflation pressure	6-64
	Unbalanced tires	⊙	—
	Excessive steering wheel play	⊙	—
Poor steering wheel return	Poor lubrication in the steering mechanisms	⊙	—
	Poor wheel alignment	⊙	—

7-6

IN CASE OF EMERGENCY

Symptom		Cause	Corrective action	Reference page
Clutch disengages poorly (manual transmission model)		Insufficient clutch fluid	Add fluid	6-90
		Excessive clutch pedal free play	⊙	—
Loud or abnormal noises	From the transmission	Insufficient transmission oil	⊙	—
		Transmission inner components faulty	⊙	—
	From differential	Insufficient differential gear oil	⊙	—
		Differential inner components faulty	⊙	—
	From the suspension	Spring pins, shackles, or stoppers worn	⊙	—
	From the propeller shaft	Poor lubrication in each component	⊙	—
		Splines or bearings worn	⊙	—
	From the transfer case	Insufficient transfer oil	⊙	—
		Transfer inner components faulty	⊙	—

When the Electronic Key Battery Goes Flat

If switching the power mode and/or starting the engine using the passive entry and start system becomes impossible due to the electronic key battery goes flat, it is possible to switch the power mode and/or start the engine by putting the electronic key close to the engine start/stop button.

Passive Entry and Start System

→ Refer to page 3-11

Engine Start/Stop Button (Models with Passive Entry and Start System)

→ Refer to page 4-116

1. Push the engine start/stop button.
The engine start/stop button indicator light will flash in amber and "PUT ELECTRONIC KEY CLOSE TO START BUTTON" will be displayed in the MID.

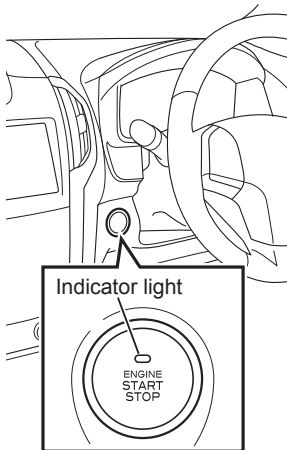

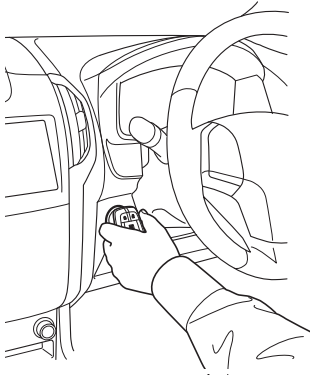

Manual transmission model

INFORMATION

TO START
STEP TO
THE CLUTCH
AND
SHIFT TO N
THEN PUSH
START BUTTON

Automatic transmission model

INFORMATION

TO START
STEP TO
THE BRAKE
THEN PUSH
START BUTTON

2. Put the electronic key near the engine start/stop button while the engine start/stop button indicator light is flashing (within 10 seconds).
3. The buzzer sounds and the flashing of the engine start/stop button indicator light will change from fast to slow and the procedure for starting the engine will be displayed in the MID.
4. When attempting to change the power mode, push the engine start/stop button within 10 seconds. When attempting to start the engine, perform the following operations within 10 seconds.
5. Make sure that the parking brake lever is fully pulled.
6. If your vehicle is a manual transmission model, make sure that the gearshift lever is in the "N" position and then depress the clutch pedal and brake pedal fully. In an automatic transmission model, make sure that the selector lever is in the "P" position and then depress the brake pedal fully.
7. With the pedal(s) depressed, push the engine start/stop button. The engine start/stop button indicator light will then change from flashing to being continuously illuminated and the engine will start.

**NOTE**

- The electronic key contains an immobilizer transponder chip, and it can be used to start the engine and change the power mode.
- After the engine start/stop button indicator light goes out, it is not possible to start the engine or change the power mode if more than approximately 10 seconds have passed. Push the engine start/stop button and put the electronic key close to the engine start/stop button again.
- The system will not function properly in the following situations:
 - A metallic object is touching or covering the handle of the key.
 - Another vehicle's transponder key is near your key.

Key with Immobilizer Transponder Chip

→ Refer to page **3-4**

Emergency Engine Stopping (Models with Passive Entry and Start System)

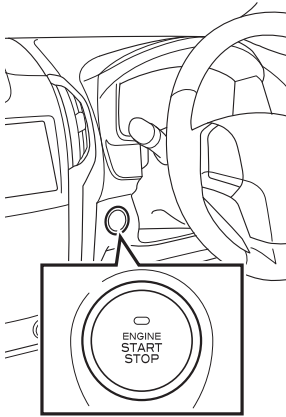

The engine can be stopped while the vehicle is in motion by performing the following operation:

- Continue pushing the engine start/stop button for 3 seconds or more.
- Push the engine start/stop button 3 times or more within 2 seconds.

WARNING

- Do not perform emergency engine stopping except in times of emergency. If the engine is stopped, brake effectiveness will be reduced and the steering wheel will be hard to turn.

When the Engine Stops While Driving
→ Refer to page 7-24

Emergency Engine Starting (Models with Passive Entry and Start System)

If the engine becomes unable to start for some reason, the engine may be able to be started by performing the following operation.



CAUTION

- Because the vehicle may move unexpectedly when the engine is started, perform the procedure after ensuring that the surrounding area is safe to do so.
- Although starting of the engine can be attempted in the "N" position for automatic transmission models, for safety reasons, it is recommended that starting be performed in the "P" position.

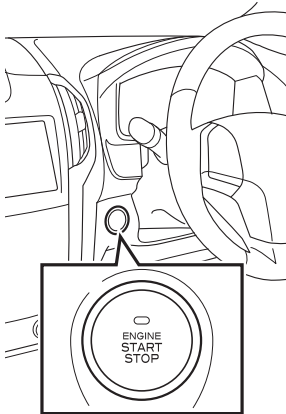

1. Push the engine start/stop button once and the power mode will switch to "ACC".
2. Make sure that the parking brake lever is fully pulled.
3. If your vehicle is a manual transmission model, make sure that the gearshift lever is in the "N" position and then depress the clutch pedal and brake pedal fully. In an automatic transmission model, make sure that the selector lever is in the "P" position and then depress the brake pedal fully.
4. With the pedal(s) depressed, continue pushing the engine start/stop button for 15 seconds or more.



NOTE

- Perform the emergency engine starting procedure within 5 minutes of the switching the power mode to "ACC".
- When attempting to start the engine, the glow plug indicator light will come on if the engine is cold. In such cases, engine starting will be delayed until the glow plugs have sufficiently warmed. Continue depressing the clutch pedal (manual transmission models) or the brake pedal (automatic transmission models) until the engine starts.
- When the engine does not start, contact your nearest Isuzu Dealer as soon as possible.

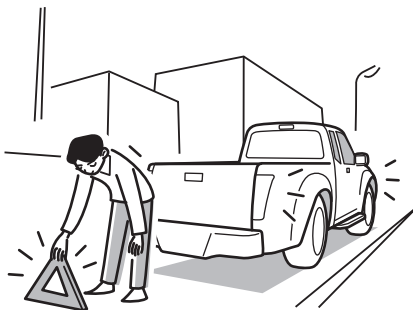
When the Vehicle Breaks Down during Driving

1. Operate the hazard warning flasher and pull the vehicle immediately over to a safe place that does not impede traffic (shoulder, verge). Place the triangle reflectors to alert other traffic to the presence of your vehicle.
2. Have the other passengers get out and wait in a safe place.
3. Walk to a safe place and take appropriate measures by using the closest telephone, etc.

**WARNING**

[If there is a fuel leak]

- Leaking fuel from the vehicle is dangerous due to possible combustion or explosion. Stop the engine immediately.

When the Tire Goes Flat



When the tire gets flat while driving, avoid hard braking, hold on to the steering wheel firmly and stop the vehicle.

If a spare tire is equipped, change the tire. If the emergency flat tire repair kit is equipped, perform the repair using the emergency flat tire repair kit.

Perform changing and repair of a tire using the emergency flat tire repair kit on a flat space to prevent obstructing other vehicles or pedestrians.

WARNING

- If you continue to drive on a flat tire, undue force will be applied to the wheel bolts, possibly causing the bolts to break and the wheel to come off.

Tools → Refer to page 6-7

Spare Tire → Refer to page 6-70

Handling the Jack → Refer to page 6-74

Changing Tires → Refer to page 6-79

How to Use the Emergency Flat Tire Repair Kit (4WD Crew Cab Models for the Singapore Market)

→ Refer to page 7-14

How to Use the Emergency Flat Tire Repair Kit (4WD Crew Cab Models for the Singapore Market)



WARNING

- The sealant is toxic. Avoid swallowing. If you mistakenly swallow any of the sealant, drink as much water as you can and get medical attention immediately.
- Make sure to use and store the sealant out of the reach of children.
- If the sealant gets in your eyes, rinse it out immediately with a large amount of water for 15 minutes or longer. If you continue to feel irritation or other abnormality, seek medical attention.
- If the sealant gets on your skin, rinse it off using soap with a large amount of water. If any abnormality occurs, seek medical attention.
- When performing emergency repairs, stop the vehicle in a safe and level location.
- If the valve insert remover is used while air remains in the tire, the valve insert may fly out.
- If the sealant bottle is shaken while the filler hose is attached, the sealant may fly out.
- When performing emergency repairs, connect the filler hose firmly to the tire valve.
- When filling with sealant, be sure to connect the filler hose firmly to the tire valve to prevent the sealant from leaking.
- When the air compressor is running, heat is generated in parts and the air compressor becomes hot. Handle with care during and after use.
- After filling with sealant, drive the vehicle slowly and carefully. Be especially careful on curves and turns.

**CAUTION**

- The emergency flat tire repair kit cannot be used in the following cases. Contact an Isuzu Dealer or roadside assistance service.
 - If there are cuts larger than approximately 4 mm (0.16 in) piercing the tire tread.
 - If there are cuts on the sidewall of the tire.
 - If the tire pressure is remarkably low and the tire is damaged by driving at a reduced tire pressure.
 - If the tire bead is completely unseated outside of the rim.
 - If the rim is damaged.
- Small punctures in the tire tread caused by a nail or screw can be sealed with the emergency flat tire repair kit.
- Do not remove nails or screws from the tire.

**ADVICE**

- Do not continue driving with a punctured tire, even for a short distance, as the tire and/or wheel may become damaged beyond repair.
- If a nail or screw becomes stuck in the tire tread, perform emergency repair without removing the nail or screw. If you remove the nail or screw first, you may be unable to perform emergency repair using the Emergency Flat Tire Repair Kit.
- Do not place the valve insert on dirty ground.
- Do not remove the inner lid of the sealant bottle.
- Turn the valve insert remover with your hand. Using tools to turn the valve insert remover may cause damage.
- Do not use the air compressor continuously for more than 10 minutes, as the motor may overheat and become damaged.
- The air compressor is not water-resistant. When using in rainy conditions, protect the air compressor from water droplets.
- The air compressor uses DC 12 V power only. Do not use other voltages.
- Do not expose the air compressor to impact, as this may cause failure. Do not disassemble or modify the air compressor.
- Do not lubricate the air compressor. Applying lubrication oil to the air compressor may cause failure.
- Blowing dusty air into the air compressor may cause failure. Do not use the air compressor on sandy locations such as on sand, etc.
- If the air compressor becomes sluggish or excessively hot while running, it is overheating. If this occurs, switch it off and leave it for 30 minutes or more.

**NOTE**

- One sealant bottle is only sufficient to perform emergency repair of one tire.
- If sealant adheres to clothing, it may be impossible to remove.
- The sealant is usable within an ambient temperature range of -30°C to 60°C (-22°F to 140°F).
- In low ambient temperatures, the sealant becomes viscous and difficult to pour. In such cases, leave the sealant inside the vehicle to warm up and make pouring easier.
- The expiration date of the sealant is 4 years after the date of manufacture. (The expiration date is indicated on the container.)
- Replace the sealant with new sealant before the expiration date. Request replacement from your Isuzu Dealer.
- Consult your Isuzu Dealer when purchasing sealant.
- The air compressor makes a loud noise when running. This does not indicate a failure.
- Do not use the air compressor for any purpose other than filling automobile tires with air.
- Use a soft cloth to wipe off any sealant adhering to the wheel. The wheel can be used after the sealant is wiped off.

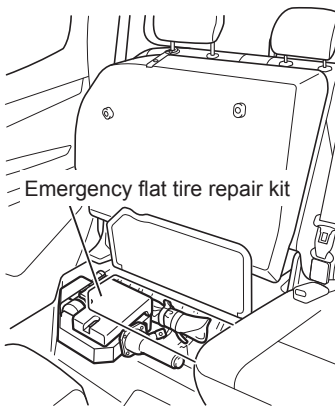
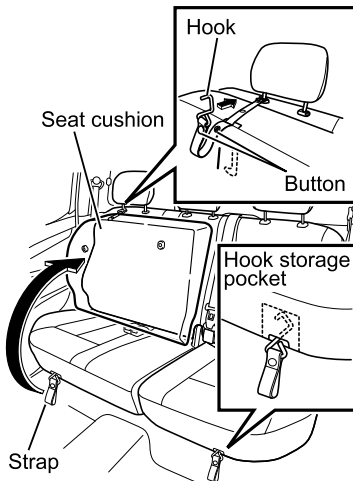

Storage Location

The emergency flat tire repair kit are positioned under the right rear seat. Pull the strap forward to raise the seat cushion. Remove the hook of the strap edge from the strap button and secure the hook to the headrest stay.

⚠ WARNING

- When raising the seat cushion, the hook of seat cushion strap must be secured to the headrest stay to keep the seat cushion locked safely in the storage position.
- When returning the seat cushion to its original position, hold the seat cushion and slowly lay it down. Finally, try to move the seat cushion to check that it is completely locked.
- After returning the seat cushion to its original position, do not forget to return the hook to the hook storage pocket.
- When returning the seat cushion to its original position, make sure the seat belt does not get trapped. In addition, make sure the seat belt lays on top of the seat cushion after returning the seat cushion to its original position.

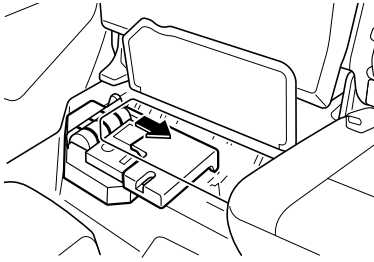

Loosen the jack release knob to remove the jack. Slide the cover of the emergency flat tire repair kit sideways, then pull out the emergency flat tire repair kit.

WARNING

- Do not remove the cover except to repair a puncture.
- If the cover is lost or damaged, obtain or replace the cover. For obtaining or replacing the cover, consult your Isuzu Dealer. Do not use a damaged cover or operate without a cover, as the sealant bottle may become damaged and leak sealant.

Kit contents

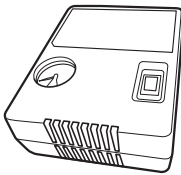

Air compressor



Sealant bottle



Filler hose



Valve insert(spare)



Speed restriction label



Extension hose
(for draining sealant)



Valve insert remover

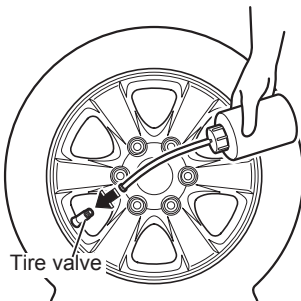
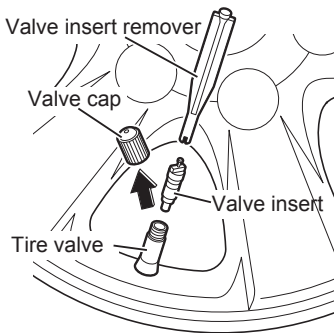
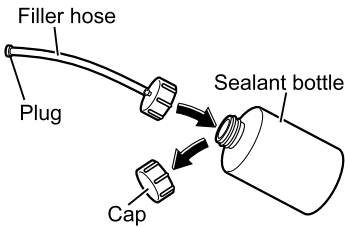
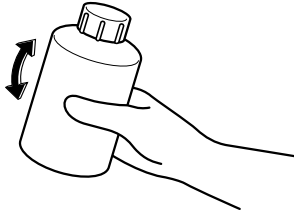

Repair

1. Take out the sealant bottle and air compressor. Shake the sealant bottle well.

2. Remove the cap of the sealant bottle, and screw the supplied filler hose onto the sealant bottle, thereby piercing the inner cap of the sealant bottle.



NOTE

- Shake the sealant bottle well before screwing the filler hose onto the sealant bottle.
- Screw the filler hose without removing the inner cap of the sealant bottle.

3. Unscrew the valve cap from the tire valve. Remove the valve insert by using the valve insert remover that is supplied. Put the valve insert in a clean place for reuse.



WARNING

- If air remains in the tire, the valve insert could shoot out. Be careful when removing the valve insert.

4. Remove the plug from the filler hose. Insert the filler hose into the tire valve.

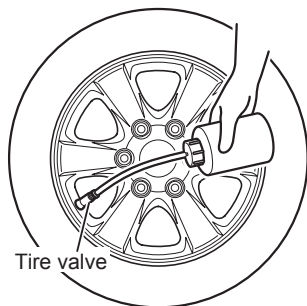

5. Hold the sealant bottle with the bottom upward and pump the sealant bottle to fill the entire contents of the sealant bottle into the tire. After filling the entire contents of the sealant bottle into the tire, pull off the filler hose. Firmly screw the valve insert into the tire valve.

If the valve insert is dirty or lost, use the spare valve insert that is supplied.

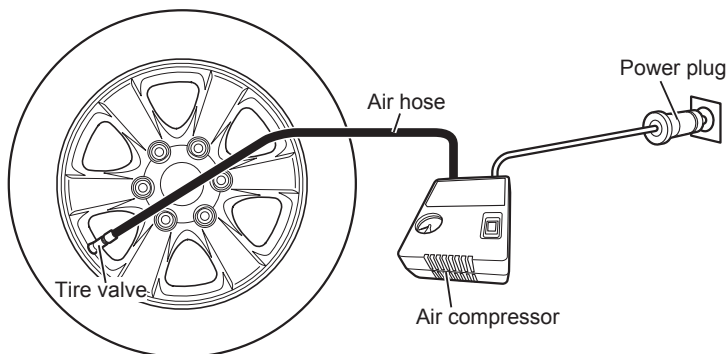

6. Screw the air hose of the air compressor into the tire valve to connect them. Install the power plug to an accessory power outlet. Turn the starter switch to the "ACC" position and turn "ON" the air compressor power. Fill the tire to the specified air pressure.

Tire Size and Tire Air Pressure

→ Refer to page 6-65

WARNING

- Do not stand next to the tire when inflating it. It could burst.

**CAUTION**

- Push the button of the air compressor to turn it ON/OFF.
- Do not operate the air compressor for longer than 25 minutes. Doing so could cause the air compressor to overheat.

If the specified level of the tire air pressure cannot be reached within 15 minutes, jack up the tire. Rotate the jacked up tire 3 times or more to spread the sealant throughout the entire tire. Then, inflate the tire again until the tire pressure reaches the specified level.

**NOTE**

- If the air pressure cannot reach the specified air pressure level, the tire may be severely damaged. In this case, the emergency flat tire repair kit cannot be used to repair the tire. Contact an Isuzu Dealer or roadside assistance service.
- If the tire gets overinflated, deflate the air by loosening the screw of the air hose halfway.

7. Inflate the tire until the air pressure in the tire reaches the specified air pressure level, and switch the air compressor switch "OFF". Next, remove the air hose and power plug. Install the valve cap on the tire valve.
8. Immediately drive the vehicle a short distance after inflating the tire to the specified air pressure. Drive carefully and do not exceed a maximum speed of 80 km/h (50 MPH).

9. After 10 minutes or 5 km (3 miles) of driving, check the tire pressure with the pressure gauge of the air compressor.

If the air pressure indicates more than **130 kPa** (1.3 kgf/cm² / **18 psi**), the emergency repair is completed. However, if the air pressure level is less than the specified air pressure, correct the tire pressure to the specified air pressure.

If the tire pressure has dropped below **130 kPa** (1.3 kgf/cm² / **18 psi**), the emergency flat tire repair kit cannot be used to repair the tire. Do not drive the vehicle and contact an Isuzu Dealer or roadside assistance service.

 **WARNING**

- Be sure to check the tire pressure and to confirm the completion of the emergency repair.

10. Affix the supplied speed restriction label in the driver's field of view, and drive carefully to the nearest Isuzu Dealer or a tire repair shop.

 **WARNING**

- Do not affix the speed restriction label to the steering pad. Also do not affix the label to the warning and indicator lights, and to the speedometer.

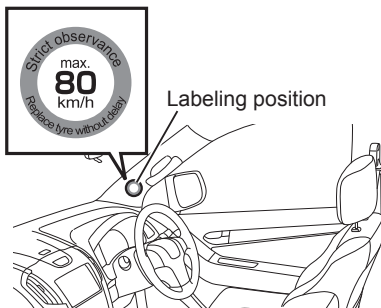

**CAUTION**

- Have the tire changed at the nearest Isuzu Dealer.
Contact a tire repair shop to fix the tire that was repaired using the emergency flat tire repair kit.
- The wheel can be reused after completely wiping sealant off with a cloth so that it does not rust, but the tire valve must be replaced with a new one.
- Give the used sealant bottle to an Isuzu Dealer for extraction of the sealant from the tire.

When the Engine Stops While Driving



As the brake booster will no longer operate, brake effectiveness will be reduced. The power steering system will not work so the steering wheel will be hard to turn. Stay calm and decrease vehicle speed by pressing the brake pedal. Then, promptly pull the vehicle over to a safe location and inspect its condition. If the engine does not start, contact the nearest Isuzu Dealer.

WARNING

- Vehicle operations will change, so stop the vehicle in a safe place with the following in mind.
 - The power steering system will not work so the steering wheel will be hard to turn. It will require more strength than during normal operation.
 - As the brake booster will no longer be functional, brake effectiveness will be greatly reduced. Be sure to apply more pressure than usual to the brake pedal.
- In models with passive entry and start system, if the engine stops while the vehicle is in motion, etc., do not open the doors until the vehicle has come to a safe stop. This is dangerous as the steering wheel lock may operate if the doors are opened. After stopping the vehicle in a safe place, immediately contact your nearest Isuzu Dealer.

NOTE

- If the engine stopped because the vehicle ran out of fuel while driving, refueling alone will not be enough to restart the engine. Bleed the fuel system after refueling the vehicle.

When the Fuel Runs Out

→ Refer to page 7-28

When the Engine Stalls and Cannot be Restarted

Place the gearshift lever (manual transmission models) or the selector lever (automatic transmission models) in the "N" position and push the vehicle to a safe place.



CAUTION

- In case of emergency with manual transmission models, place the gearshift lever in "R (reverse)", "1 (1st gear)" or "2 (2nd gear)" if the starter turns over. Then, keep turning the starter switch with your foot off the clutch pedal to move the vehicle (models without passive entry and start system). However, doing so may cause damage to the starter.

When the Brakes Do not Work



If the brakes unexpectedly stop working, reduce speed by quickly shifting gears down incrementally to 1st gear. Gradually pull the parking brake lever while firmly holding on to the steering wheel and stop the vehicle on the side of the road. After stopping the vehicle, immediately contact the nearest Isuzu Dealer.



CAUTION

- It is very dangerous to suddenly pull the parking brake lever all the way while moving at high speed. Reduce speed first by shifting down and then gradually pull the parking brake lever.
- Do not continue driving with the brakes in a non-working condition.

When the Battery Goes Flat

Use a jumper cable (sold separately) and the batteries of another vehicle to start the engine in this sequence.



CAUTION

- For safety and the protection of the vehicle, do not push-start the vehicle.
- Make sure that the booster batteries in the vehicle providing the charge have the same voltage as the disabled vehicle.
- Never let the battery's positive and negative terminals to come into contact with one another.
- Never let the clips come into contact with one another when connecting the cables.
- Ask the nearest Isuzu Dealer to recharge the battery.
- Do not disconnect a battery terminal with the engine running. It could cause a breakdown in the electrical system.

Upper level line

Lower level line

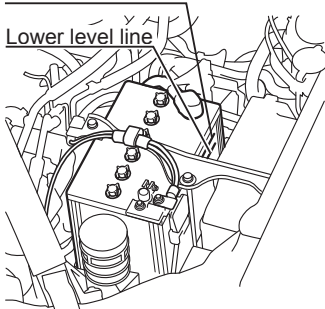

1. Check the battery fluid level in the disabled vehicle.
2. Use a vehicle that has a charged battery with the same voltage.

3. Connect the jumper cables in the numbered sequence in the drawing.

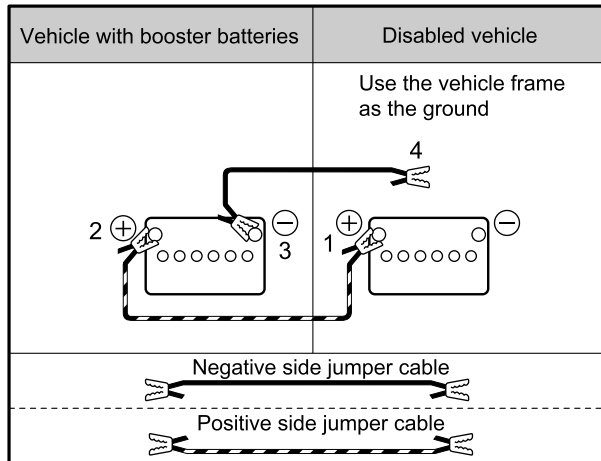

4. After connecting the cables, start the engine of the vehicle with the booster battery. Slightly rev up the engine of the vehicle with the booster battery and start the engine of the disabled vehicle.

Starting the Engine

→ Refer to page 4-4

5. If the engine in the disabled vehicle starts, remove the jumper cables in the reverse sequence as they were connected.

WARNING

- Check the battery fluid level before connecting the jumper cables. Usage or charging of the battery when the battery fluid is below the lower level line can accelerate deterioration, and give rise to dangerous situations such as the generation of heat and may even cause an explosion. Perform the work after adding the battery fluid.
- A vehicle battery generates flammable gas that could explode. Be careful of the following to avoid creating sparks.
 - Do not connect one end of the jumper cable shown in step 4 in the drawing directly to the battery's negative terminal. Connect the jumper cable to a metal part of the engine that is away from the battery.
 - Do not let the cable connected to the positive terminal come in contact with the cable connected to the negative terminal or the body.
 - Keep flames away from the battery.
- Be careful not to become entangled in any belts when connecting and removing the cables.

**NOTE**

- When it is difficult to start the engine in a cold location, after connecting the jumper cables, start the engine of the vehicle with the booster batteries. Wait a few minutes before starting the engine of the disabled vehicle.

When the Fuel Runs Out**Models with MID**

When the fuel runs out, air will enter the fuel system, so refueling alone will not be enough to restart the engine. Use the following methods to bleed the fuel system.

Models with LCD

Bleeding the Fuel System

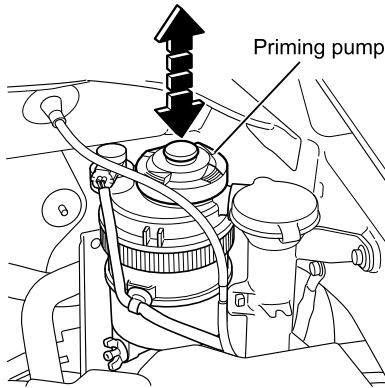

1. Operate the priming pump up and down to perform air bleeding. Repeatedly operate the priming pump up and down until its operational force becomes strong.
2. Without depressing the accelerator pedal, start the engine.

Starting the Engine

→ Refer to page 4-4

3. After the engine has started, allow it to idle for 1 minute.
4. Slowly and fully depress the accelerator pedal to increase the engine r/min, then release your foot from the pedal once the tachometer pointer comes close to the red zone (Repeat this operation a few times).
5. If the engine could not be started, try again from step 1.



ADVICE

- Insufficient air bleeding can result in faulty engine operation. Bleeding of the fuel system should always be performed using the correct procedure.
- Insufficient air bleeding may cause the malfunction indicator light (MIL) or SVS indicator light to illuminate, or improper engine performance.

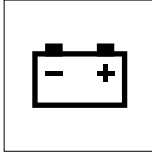
When the Generator Warning Light Comes On

When this warning light comes on, the charging system may have failed. Immediately stop the vehicle in a safe place, perform checks and take corrective action.

Generator Warning Light

→ Refer to page 4-82

Check and Corrective Action

Check to see if the fan belt is broken or loose.

- If the fan belt is loose, adjust the tension.
- If there is no abnormality in the fan belt, contact the nearest Isuzu Dealer.

Fan Belt/Air Conditioning Compressor Belt/Accessory Belt

→ Refer to page 6-47

**CAUTION**

- Do not drive the vehicle when the warning light is on. The battery can be discharged.

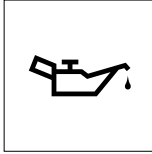
When the Engine Oil Pressure Warning Light Comes On

When this warning light comes on, the oil pressure is too low.

Immediately stop the vehicle in a safe place, stop the engine, perform checks and then take corrective action.

Engine Oil Pressure Warning Light

→ Refer to page 4-77

Check and Corrective Action

1. Check the engine oil level.
2. If the engine oil level is too low, check for leaks and add oil.
3. When the oil level is normal and there are no oil leaks, the oil filter may be clogged.

Replace the oil filter. Have the engine oil filter replacement performed at an Isuzu Dealer.

4. When the oil level is normal and the oil filter is not clogged, but there are oil leaks, contact the nearest Isuzu Dealer.

Engine Oil → Refer to page 6-20

**CAUTION**

- Do not drive the vehicle when the warning light is on. It could damage the engine.

**NOTE**

- In winter, when the engine oil temperature is low and the oil viscosity is high, the light might come on for a time. It will go out when the engine warms up.

When the Warning Light Comes On

If the Warning Light and Indicator Light come on, refer to chapter 4.

Warning and Indicator Lights

→ Refer to page 4-70

When the Engine Overheats

If engine power drops and the engine coolant temperature gauge goes up above the upper limit of the safety zone and then enters "H" zone and flashes at the time, the engine is overheating. The engine overheat warning light will come on and the engine overheat warning buzzer will sound. Either steam or boiling water will squirt out of the radiator. Take the following corrective actions immediately.

Models with MID

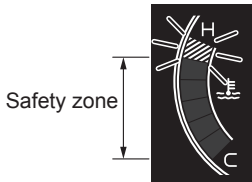

Models with LCD

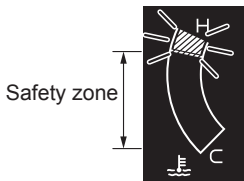

Engine overheat warning light (models with MID)



Engine overheat warning light (models with LCD)

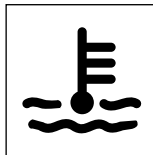

1. Operate the hazard warning flasher and pull the vehicle immediately over to a safe place that does not impede traffic (shoulder, verge) and park it.
2. Lower the temperature of the engine for a while with the engine idling.



WARNING

- If steam or abnormal noises are being emitted from within the engine compartment, immediately stop the engine and contact the nearest Isuzu Dealer. Should this happen, do not open the engine hood as you may be scalded by hot water that could possibly blow out.



ADVICE

- Do not stop the engine immediately. Otherwise, the engine may seize.
 - Turn off the air conditioner if it is running.
 - Stop the engine if the engine coolant temperature gauge does not go down even when the engine is idled. Contact the nearest Isuzu Dealer.
3. When the gauge of the engine coolant temperature gauge returns to the middle of the safety zone, stop the engine.

WARNING

- Even when the engine has been stopped, the engine coolant in the radiator remains under pressure. Immediately removing the radiator cap could cause steam or hot water to blow out, and you could be scalded as a result. The engine coolant in the reserve tank may also be hot. Immediately removing the cap could cause hot water to blow out, and possibly scald you.
- When removing the radiator cap and reserve tank cap, use a thick cloth to cover the cap and turn it little by little.

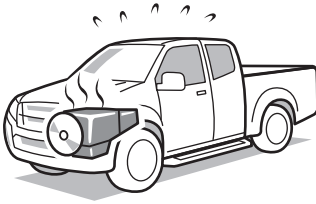

4. Check the engine coolant level in the reserve tank and radiator after the engine has sufficiently cooled. If the level is insufficient, add engine coolant. Also, check to see if the fan belt is loose or has been damaged.

ADVICE

- Make sure that the gauge on the engine coolant temperature gauge is below "C" before adding engine coolant. Adding engine coolant when the engine is not sufficiently cool could cause a breakdown in the engine or damage it.
- When tap water only has been used for engine coolant in an emergency, adjust the engine coolant concentration as soon as possible.

Warning Buzzer → Refer to page 4-111

Engine Coolant → Refer to page 6-40

**Fan Belt/Air Conditioning Compressor
Belt/Accessory Belt**

→ Refer to page 6-47

When the Bulb Does not Come On

1. Check each bulb for blowout.
2. If a bulb has blown out, replace it. Always switch the power mode to "OFF" (models with passive entry and start system) or turn the starter switch to the "LOCK" position (models without passive entry and start system) and place all the other switches to the off position before replacing the blown bulbs.
3. If the bulb has not blown out, the fault may be in the wiring. Contact the nearest Isuzu Dealer.



CAUTION

- Using bulbs with a wattage other than that specified could cause the bulb or the wiring to become hot. This could result in the warping of the lens and case, and it could also lead to the outbreak of fire.
- Bulbs are hot immediately after they go out. When replacing the bulbs, avoid being burned by making sure they are fully cooled.
- Never drive the vehicle with the bulbs not working. This could result in an accident.
- Halogen bulbs contain pressurized gas. Be careful when handling halogen bulbs as damaging or dropping them could cause an explosion.



ADVICE

- When one bulb of a pair of lights, such as a headlight blows out, the other bulb is approaching the end of its useful life. We recommend that both be changed at the same time.



NOTE

- Be sure to adjust the headlight aim to prevent other drivers from becoming blinded. Have the headlight aim adjusted at the nearest Isuzu Dealer.
- For the lights (lighting equipment) such as headlights, inside of the lens can mist up momentarily when driving in the rain or during the car wash. Also, the temperature difference between inside and outside of the lights can sometimes cause the water condensation inside the lens. This is not abnormal because this is the same phenomenon as the windshield or door glass fogs up when it rains. If it is demisted minutes after the light is turned on, things are normal.

Bulb Wattage

Position	Lights		Bulb wattage
Front	Halogen headlight	High beam	60 W
		Low beam	55 W
	Clearance light/daytime running light		LED
	Turn signal light		21 W (Amber)
	Fog light		19 W
Side	Turn signal light	Outside rearview mirror mounted type	LED
		Front door mounted type	5 W
Rear	Taillight and stop light	LED type	LED
		Bulb type	5/21 W
	Turn signal light	Standard type	21 W (Amber)
		Horizontal type	21 W
	Back up light		21 W
	License plate light		5 W
	Rear fog light		21 W
High mounted stop light		5 W	
Interior	Map lights		5 W
	Dome light		10 W



NOTE

- Contact the nearest Isuzu Dealer when replacing lights that are not listed here.

Replacing the High Beam Headlight Bulbs

1. Open the engine hood and engage the support.

Engine Hood → Refer to page 6-10

2. Turn the bulb counterclockwise to remove it.

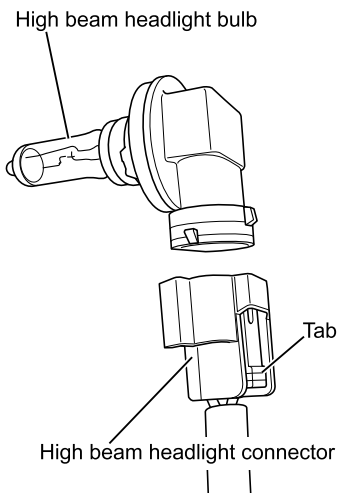
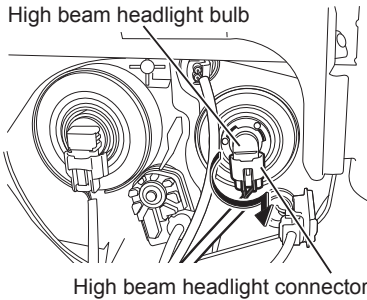

3. Disconnect the connector from the bulb. Remove the connector by pushing the tab.

4. Connect the connector to the new bulb.



ADVICE

- Do not touch the glass of the bulb with your hand. Soiling the glass will cause the bulb to blow out.

5. Insert the bulb and turn it clockwise to lock it securely.

**ADVICE**

- If the socket is not locked securely, water could get inside the light and lead to a malfunction.

Replacing the Low Beam Headlight Bulbs

1. Open the engine hood and engage the support.

Engine Hood → Refer to page 6-10

2. Turn the bulb counterclockwise to remove it.

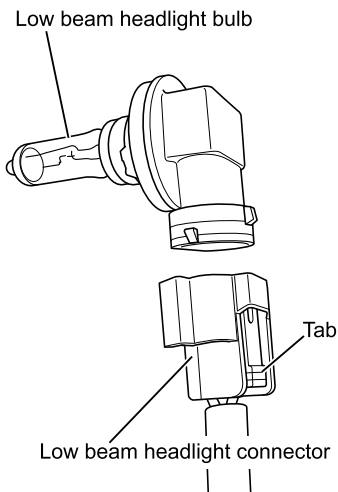
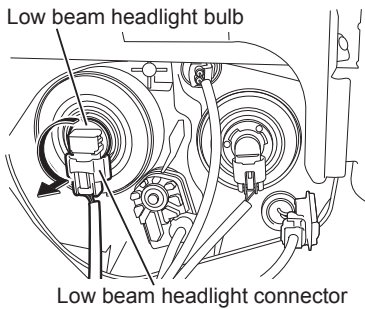

3. Disconnect the connector from the bulb. Remove the connector by pushing the tab.
4. Connect the connector to the new bulb.

**ADVICE**

- Do not touch the glass of the bulb with your hand. Soiling the glass will cause the bulb to blow out.

5. Insert the bulb and turn it clockwise to lock it securely.

**ADVICE**

- If the socket is not locked securely, water could get inside the light and lead to a malfunction.

Replacing the Front Turn Signal Light Bulbs**CAUTION**

- Do not replace a bulb with one other than the specified wattage. This will cause abnormal flashing, particularly for turn signal lights.

1. Open the engine hood and engage the support.

Engine Hood → Refer to page 6-10

2. Turn the socket counterclockwise to remove it.

**NOTE**

- Pliers may be used if it is not possible to turn the socket by hand.

Turn signal light socket

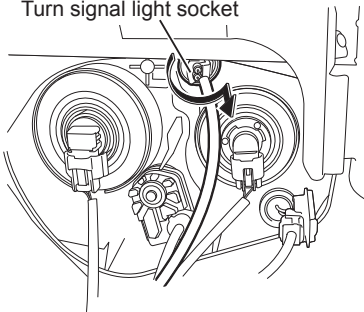

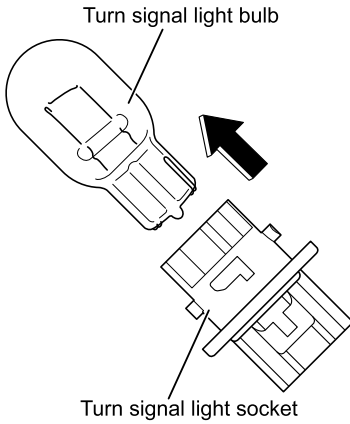

3. Pull out the bulb from the socket.

4. Insert a new bulb into the socket.

5. Insert the socket and turn it clockwise to lock it securely.

**ADVICE**

- If the socket is not locked securely, water could get inside the light and lead to a malfunction.

Replacing the Turn Signal Light Bulbs (Front Door Mounted Type)

1. While sliding the turn signal light (front door mounted type) toward the front of the vehicle, slide and then pull it to expose the rear part of the light. Disengage the clip on the side of the rear of the light from the door panel. When the clip has been removed, pull the light out while sliding it out toward the rear of the vehicle.

2. Loosen the socket by turning it counterclockwise.

3. Pull out the bulb from the socket.

4. Insert a new bulb into the socket.

5. Insert the socket and turn it clockwise to lock it securely.

6. Insert the clip on the back of the rear part of the light into the door panel. Push the front part of the light into the door panel, and insert the clip on the back of the front part of the light in the door panel.

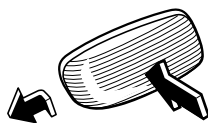
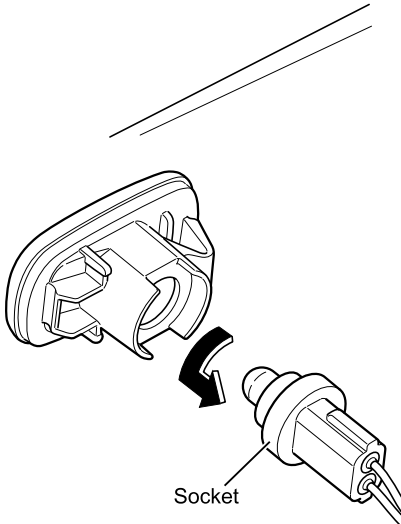
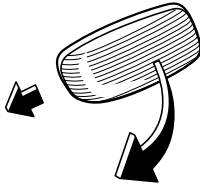

Replacing the Rear Combination Light Bulbs



NOTE

- If the stop and tail light bulb is an LED specification, have the stop and tail light bulb replaced at an Isuzu Dealer.

1. Open the tailgate. Remove the 2 screws. Remove the rear combination lights.

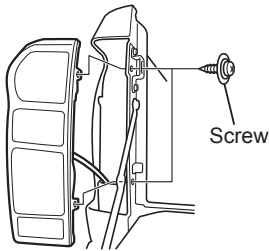

2. Turn the socket of the replacing bulb counterclockwise to remove it.

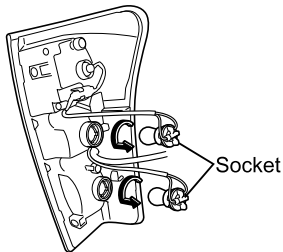

3. Pull out the bulb from the socket.

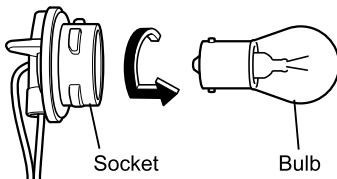

4. Insert a new bulb into the socket.
5. Insert the socket and turn it clockwise to lock it securely.

**ADVICE**

- If the socket is not locked securely, water could get inside the light and lead to a malfunction.

6. Install the rear combination lights, and then tighten the 2 screws to affix them.

Replacing the Bulbs of Rear Turn Signal Lights, Taillights, Stop Lights, and Back Up Lights (Horizontal Type)

1. Loosen the screws and remove the lens.
2. Loosen the bulb by turning it counterclockwise while pressing on it.
3. To install the lights, perform the removal procedure in reverse.

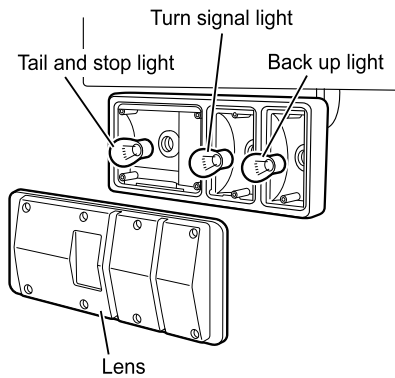

Replacing the Rear Fog Light Bulb

1. Remove the screws retaining the lens and remove the lens.
2. Loosen the bulb by turning it counterclockwise while pressing on it.
3. To install the lights, perform the removal procedure in reverse.

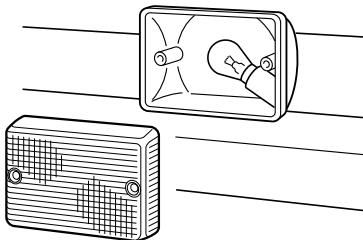

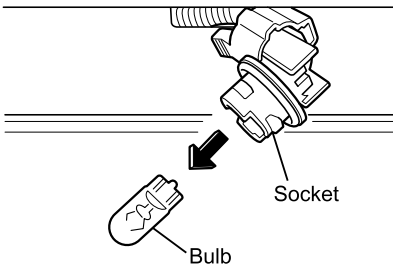
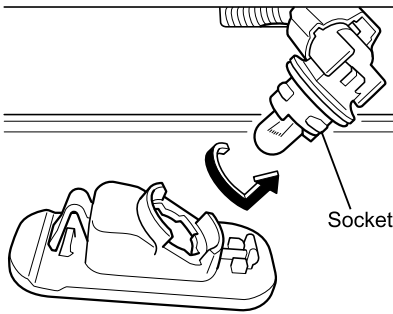
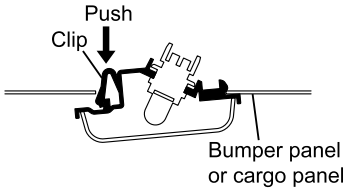
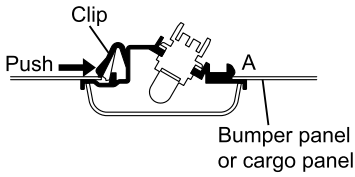

Replacing the License Plate Light Bulbs

1. Push the clip on the back of the license plate light towards "A" to release the lock.
2. When the clip lock has been released, push the clip to remove the license plate light.
3. Loosen the socket by turning it counterclockwise.
4. Pull out the bulb from the socket.
5. Insert a new bulb into the socket.
6. Insert the socket and turn it clockwise to lock it securely.

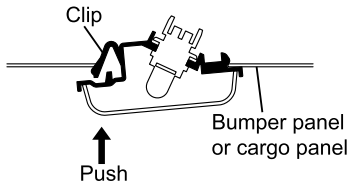
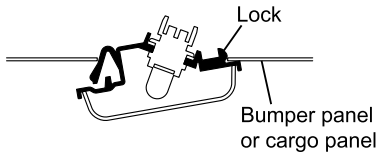

7. Insert the license plate light lock into the bumper panel or cargo panel.

8. Push the license plate light at the clip into the bumper panel or cargo panel to install the clip.

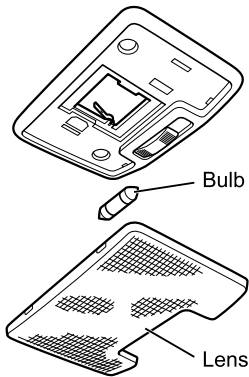

Replacing the Dome Light Bulb

1. Use a flat-head screwdriver or similar tool to remove the lens. Remove the bulb.
2. To install the lights, follow the removal procedure in reverse.

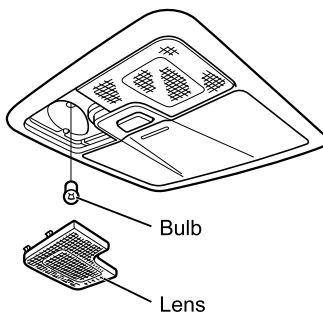

Replacing the Map Light Bulbs (with Over Head Console)

1. Remove the lens and pull out the bulb.
2. To install the lights, perform the removal procedure in reverse.

**Replacing the Map Light Bulbs
(without Over Head Console)**

1. The light assembly can be removed easily by pulling down with your hand.

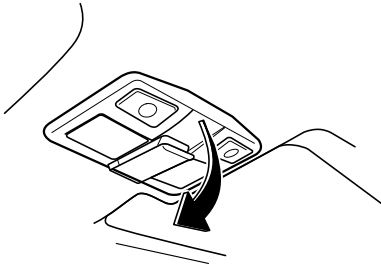

2. Loosen the socket by turning it counterclockwise.

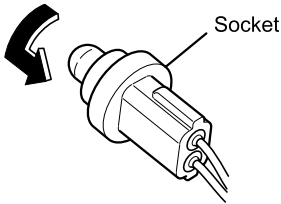

3. Pull out the bulb from the socket.

4. To install the lights, perform the removal procedure in reverse.

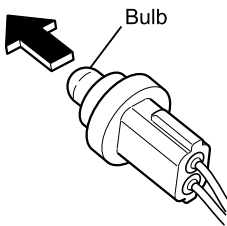
**Have the Following Bulb
Replacement Work Performed at an
Isuzu Dealer**

- Clearance lights/daytime running lights
- Front fog lights
- Turn signal lights (Outside rearview mirror mounted type)
- Taillights and stop lights (LED type)
- High mounted stop light

Replacing the Fuses and Relays

When the lights will not come on or flash, or the equipment in the electrical system does not operate, check to see if a fuse has blown.



ADVICE

- It is not necessary to open or close the cover unless trouble is found.
- The fuse and relay box structure makes it difficult for water to enter. If you should spill water or a beverage on the cover, however, wipe it off before opening the cover.
- The area around the cover will get warm when the vehicle is being driven, but this is not abnormal.

The Location of Fuses and Relays

The fuses and relays are inside the cab and the engine compartment. When inspecting or replacing the fuses or relays in the cab, remove the small article storage pocket that is located on the lower driver side part of the instrument panel. When inspecting or replacing the fuses or relays in the engine compartment, open the cover of the fuse and relay box that is located on the front left side of the engine compartment.



NOTE

- The fuse layout is shown on the opposite side of the small article storage pocket.

Removal method

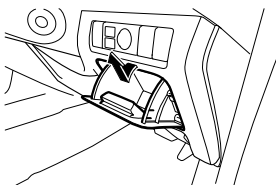

Installation method



Removing the Small Article Storage Pocket

Pull the small article storage pocket towards you to open it. While in the open position, pull it up until it unlocks from the hinge to remove it.

To install the small article storage pocket, perform the removal procedure in reverse.

Replacing Fuses

1. Before replacing fuses, be sure to switch the power mode to "OFF" (models with passive entry and start system) or turn the starter switch to the "LOCK" position (models without passive entry and start system) and pull back on the parking brake lever.
2. Place the fuse puller on the fuse and pull it out. (The fuse puller is stored in the fuse box inside the engine compartment.)

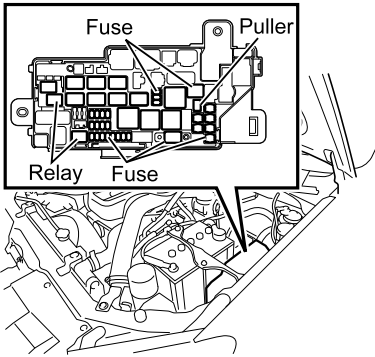
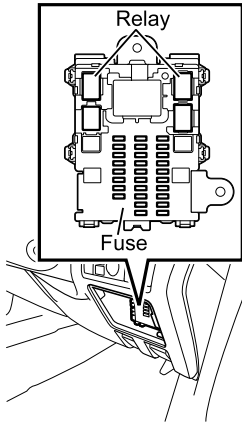

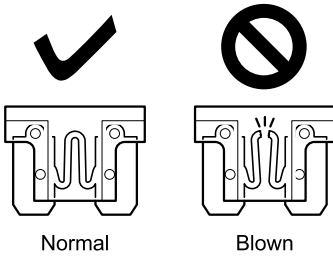

3. If the fuse appears as shown in the right-hand side of the diagram at left, the fuse is blown. Replace with a spare fuse. Spare fuses are stored in the fuse box inside the engine compartment and within the instrument panel.

 **WARNING**

- Use fuses of the same amperage for replacement. Do not use any other fuses than those designated.
- Using fuses other than those specified could result in fire or damage to the equipment.
- If the new fuses blow right away, contact the nearest Isuzu Dealer.

Replacing Relays

When replacing the relays, contact the nearest Isuzu Dealer.

Fuse and Relay Location

Fuse locations: engine compartment

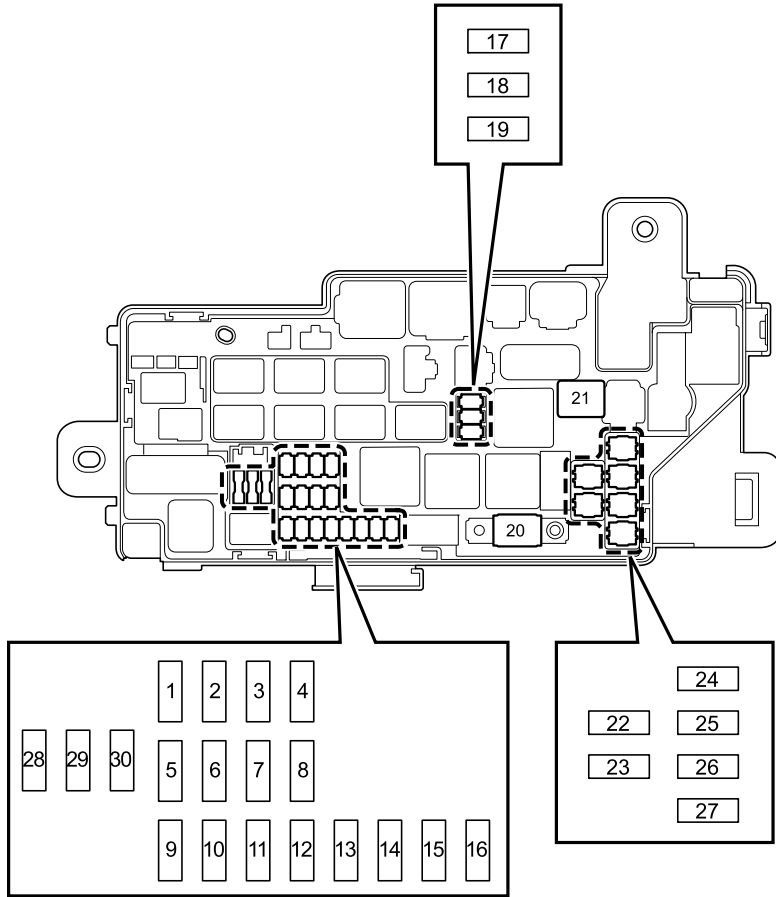

No.	Description	Rating	No.	Description	Rating
1	H/LIGHT RH LO	10A	15	H/LIGHT LH HI	10A
2	H/LIGHT LH LO	10A	16	H/LIGHT RH HI	10A
3	PCV HEATER	10A	17	TAIL LIGHT LH/ILLUMI	10A
	PESS (+B)	10A	18	TAIL LIGHT RH	10A
4	ENGINE*3	10A	19	A/C	10A
	ENGINE*4	15A	20	MAIN	120A
5	RR FOG LIGHT	10A	21	IG-2	60A
6	TRAILER	20A	22	GLOW	60A
7	ESC	10A	23	BLOWER	30A
	STRG LOCK	10A	24	ABS_1/ESC_1	50A
8	FRT FOG LIGHT	5A	25	ECM	40A
9	FRT WIPER	20A	26	ABS_2/ESC_2	30A
10	STOP LIGHT	15A	27	IG-1*1	30A
11	HAZARD	15A		IG-1*2	40A
12	HORN	10A	28	SPARE	5A
13	IBS/ACG(S)	10A	29	SPARE	10A
14	TCM_B/DRM_B*3	10A	30	SPARE	15A
	TCM_B/DRM_B*4	15A			

*1: Models with passive entry and start system.

*2: Models without passive entry and start system.

*3: Models for the Singapore market.

*4: Models other than those for the Singapore market.



NOTE

- Depending on the equipment installed, or on the vehicle destination or model, fuses may not be installed at the location where the fuse name is shown in the table.

Relay locations: engine compartment

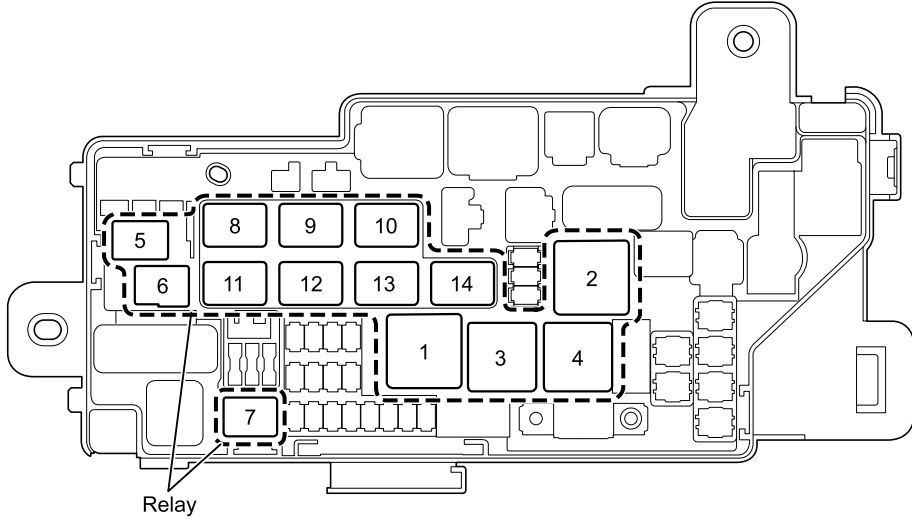

No.	Description
1	HEATER
2	ECM MAIN
3	GLOW
4	STARTER
5	DRL1
6	STARTER CUT
7	HEAD LIGHT DIMMER

No.	Description
8	HEAD LIGHT
9	TAIL LIGHT
10	FOG LIGHT
11	HORN
12	A/C COMPRESSOR
13	THERMO
14	REAR FOG LIGHT



NOTE

- Depending on the equipment installed, or on the vehicle destination or model, relays may not be installed at the location where the relay name is shown in the table.

Fuse and relay locations: instrument panel (right-hand drive)

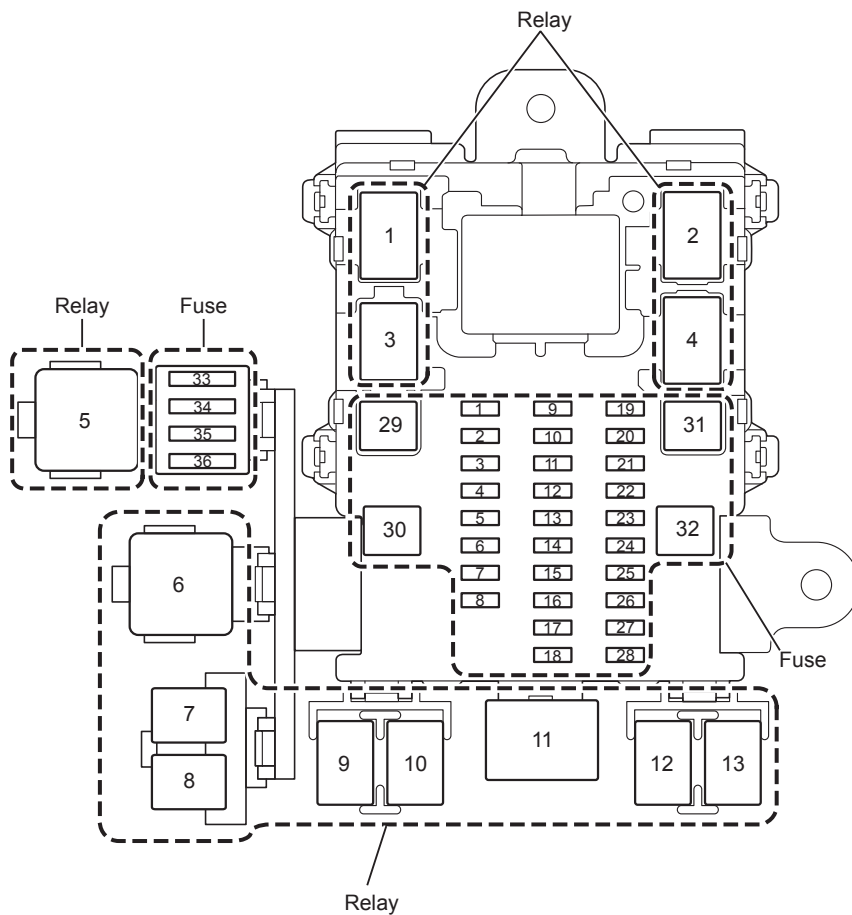

Fuse and relay locations: instrument panel (left-hand drive)

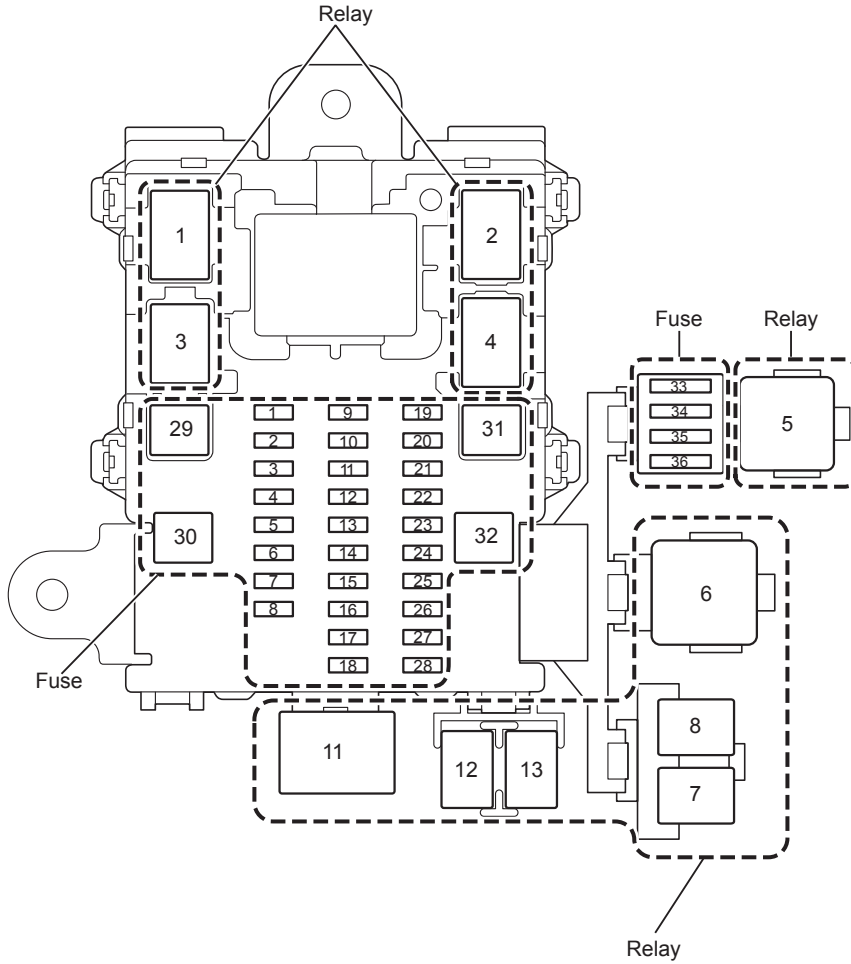

No.	Relay name
1	ACC SOCKET
2	RR DEFOGGER
3	BLANK
4	POWER WINDOW
5	FRT WIPER
6	IG1
7	IG2
8	ACC
9	DEAD LOCK
10	BLANK
11	RR DEFOGGER TIMER
12	BLANK
13	ESC

No.	Fuse name	Rating
1	KEY INT LOCK	10A
2	CIGAR LIGHTER	15A
3	AUDIO	10A
4	ELEC (IG2)	10A
5	H/LAMP LEVELING	10A
6	TURN LIGHT	10A
7	TRAILER	10A
8	SEAT HEATER	15A
9	PESS	10A
10	BACK LIGHT	15A
11	ENGINE (IG)	10A
12	METER	10A
13	TCM	15A
14	4WD	10A
15	ABS	10A
16	FRT WIPER	20A
17	SRS	10A
18	DRL	10A
19	ELEC (IG1)	10A
20	ACC SOCKET	15A
21	DOOR LOCK	20A

No.	Fuse name	Rating
22	ESC*1	10A
	SPARE FUSE*2	20A
23	SPARE FUSE*1	20A
	STARTER*2	10A
24	BCM	10A
25	AUDIO (+B)	15A
26	ROOM	10A
27	4WD (+B)	10A
28	METER (+B)	10A
29	AUDIO & CIGAR (ACC)	20A
30	POWER SEAT	20A
31	RR DEFOGGER	20A
32	POWER WINDOW	30A
33	BLANK	—
34	BLANK	—
35	BLANK	—
36	PCV HEATER	10A

*1: Models with passive entry and start system.

*2: Models without passive entry and start system.

**NOTE**

- Depending on the equipment installed, or on the vehicle destination or model, fuses or relays may not be installed at the location where the fuse or relay name is shown in the table.
- For automatic transmission models with a passive entry and start system, if the back light fuse is blown or has been replaced, the check system warning light may be displayed in the multi-information display (MID). When this happens, perform the following procedure:
 - With the selector lever in the "N" position, switch the power mode to "ON" and leave it for 5 seconds or more, or until the check system warning light goes out.
 - To start the engine, follow the normal engine starting procedure after switching the power mode once to "OFF".
- If the check system warning light continues to be displayed even after performing the above procedures, contact the nearest Isuzu Dealer.

Starting the Engine

→ Refer to page 4-4

When Driving on Bad Roads

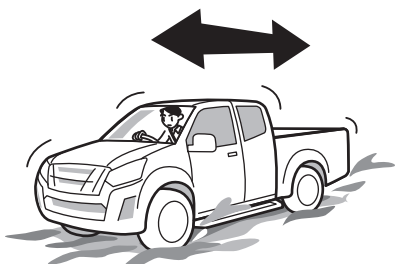

If the vehicle gets stuck in mud, pressing the accelerator pedal more than necessary will simply dig the vehicle deeper into the mud and make it harder to extricate. Either put stones, tree branches or blankets under the tires to gain traction or repeatedly drive forward and backward to use the vehicle's momentum to extricate it.



WARNING

- When the vehicle is stuck and people or objects are nearby, do not drive the vehicle forward and backward. When driving the vehicle forward and backward, the vehicle may suddenly become unstuck and injure nearby people or cause damage to objects.



NOTE

- On a muddy road with an automatic transmission model, by depressing the brake pedal you can make a standing start in the manual mode 2nd gear and move the selector lever to the "+" (upshift) position. This provides better traction and safer vehicle operation.
- When you want to free the vehicle from mud where the tires may slip slightly by increasing the engine speed, you can press the ESC OFF switch to disable just the traction control system (TCS).

Selector Lever → Refer to page 4-141
Electronic Stability Control (ESC)
→ Refer to page 4-163

Towing

To move a disabled vehicle, it is best to rely on the nearest Isuzu Dealer or someone in the wrecker or tow vehicle business. If that is not possible, follow these procedures. When towing, use appropriate equipment and comply with local legal requirements. Do not try to start the engine by towing or pushing the vehicle.

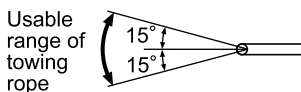
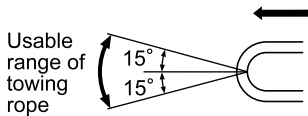
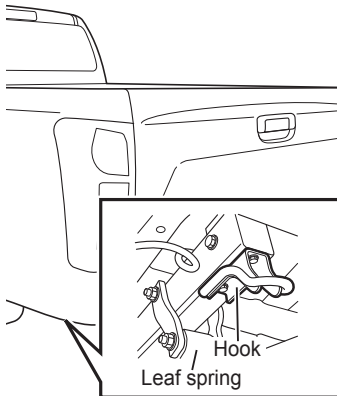
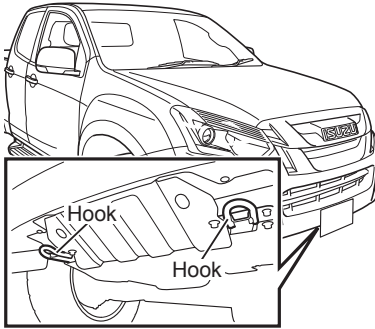

CAUTION

- Do not tow a vehicle at an angle of greater than 15°. This could exert too much stress on the vehicle and damage it.
- Attach a rope to the towing hook only. Attaching a rope to other part of the vehicle could damage it.
- Make sure there are no people near the towing rope and hook before towing a vehicle. If the rope snaps or the vehicle falls off the hook and is damaged, people nearby may be injured or objects may be damaged.
- The towing hook is for use to tow a vehicle with about the same weight as the towing vehicle on good roads.
- Follow the instructions of the equipment manufacturer.
- A separate safety chain must be used.
- Do not tow a vehicle that is attached to another vehicle.
- If the vehicle does not move even when towed, stop the towing procedure. Contact the nearest Isuzu Dealer or a towing service for assistance.

When Towed

 **WARNING**

- Before towing, make sure that the towing hook is in good condition and that the fixing bolts are tightened properly.

 **CAUTION**

- Whenever possible, tow a vehicle with the engine started.
If the engine is not started:
 - The brakes will not be as effective;
 - The steering wheel will be hard to turn;
 - The steering wheel could lock, making it impossible to turn. This is extremely dangerous (particularly when the key is removed).
- In models with a passive entry and start system, when the battery voltage of the vehicle is low, the power mode may not be able to switch. It may prevent unlocking of the steering wheel lock. If that happens, use a jumper cable (sold separately) and the batteries of another vehicle to switch the power mode (unlock the steering wheel lock).
- In models with passive entry and start system, when the engine start/stop button malfunctions, the steering wheel lock will be unable to be unlocked and towing will not be possible.

[Request a tow vehicle in case of one of the following conditions]

- When the vehicle will descend long hills. (The brakes could overheat and become ineffective.)
- When the vehicle breaks down on a highway.

**ADVICE**

- Whenever possible, transport the vehicle with all wheels off the ground using a flatbed truck, etc. If you cannot avoid towing the vehicle with the front wheels/rear wheels/all wheels on the ground, tow at a speed of 30 km/h (19 MPH) or less and a towing distance within 80 km (50 miles).
- For 4WD vehicles, set the 4WD switch to the "2H" position and confirm that the 4WD indicator light has turned off. If the 4WD indicator light does not turn off, transport the vehicle with all four wheels off the ground using a flatbed truck, etc.
- For 2WD models without High-Ride suspension, remove the cover of the front bumper extension located in front of the front towing hook before attaching a rope to the front towing hook.
- If the manual transmission, automatic transmission, or differential is damaged, transport the vehicle with all four wheels off the ground using a flatbed truck, etc.

**NOTE**

- Depending on the model, one or two front towing hooks will be equipped.

4WD Switch → Refer to page 4-177

Passive Entry and Start System

→ Refer to page 3-11

**Engine Start/Stop Button (Models with
Passive Entry and Start System)**

→ Refer to page 4-116

When the Battery Goes Flat

→ Refer to page 7-26

All Four Wheels On Ground

When it is possible to operate the steering wheel, the vehicle can be towed with all wheels on the ground.

However, the power steering will not be able to provide any power assist when the engine cannot be started.

1. For 2WD models without High-Ride suspension, remove the cover of the front bumper extension. The cover can be removed by pushing Tab A and Tab B to release the lock.

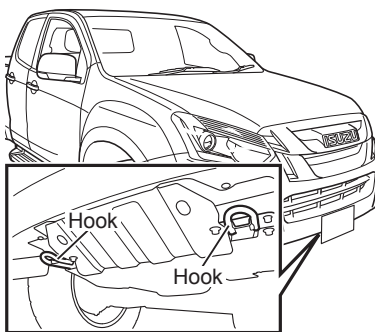
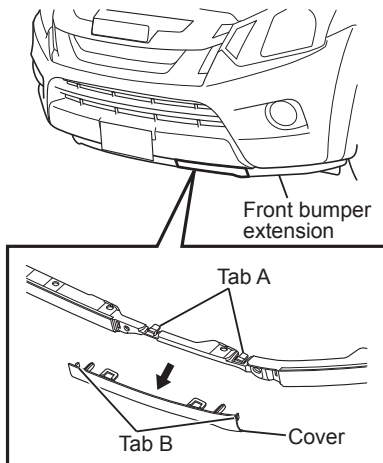

2. Firmly attach a rope to the front towing hook on the same side. The driver must be inside the cabin to control the steering wheels and brake. Switch the power mode to "ACC" (models with passive entry and start system) or turn the starter switch to the "ACC" position (models without passive entry and start system).
3. For manual transmission vehicles, place the gearshift lever in the "N" position and release the parking brake. For automatic transmission vehicles, place the selector lever in the "N" position and release the parking brake. For 4WD vehicles, set the 4WD switch to the "2H" position and confirm that the 4WD indicator light has turned off.

4WD Switch → Refer to page 4-177

4. During towing, carefully watch the stop lights of the towing vehicle in order to prevent the rope from becoming slack. Tow the vehicle gently, ensuring that there are no strong impacts or lateral forces applied to the vehicle.

Front Wheels Off the Ground

For manual transmission vehicles, place the gearshift lever in the "N" position and release the parking brake. For automatic transmission vehicles, place the selector lever in the "N" position and release the parking brake. For 4WD vehicles, set the 4WD switch to the "2H" position and confirm that the 4WD indicator light has turned off.

4WD Switch → Refer to page 4-177

Rear Wheels Off the Ground

1. For manual transmission vehicles, place the gearshift lever in the "N" position. For automatic transmission vehicles, place the selector lever in the "N" position. For 4WD vehicles, set the 4WD switch to the "2H" position and confirm that the 4WD indicator light has turned off.

4WD Switch → Refer to page 4-177

2. Secure the steering wheel in order to keep it in a straight position. Switch the power mode to "ACC" (models with passive entry and start system) or turn the starter switch to the "ACC" position (models without passive entry and start system).



ADVICE

- When towing, locking the steering wheel by switching the power mode to "OFF" (models with passive entry and start system) or turning the starter switch to the "LOCK" position (models without passive entry and start system) may result in damage to the lock mechanism.

When Towing

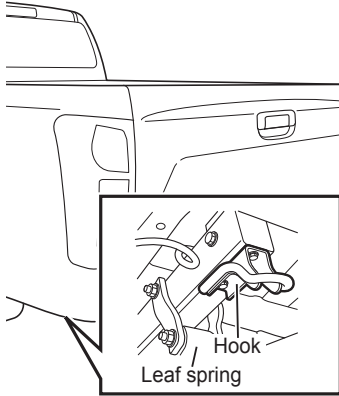

1. Firmly attach a rope to the front towing hook on the same side.
2. During towing, tow the vehicle gently ensure that there is no strong shock or lateral force applied to the vehicle.

**ADVICE**

- Do not tow a vehicle heavier than the towing vehicle. The traction strength has been set up to be smaller than the weight of the towing vehicle.

**NOTE**

- Depending on the model, a rear towing hook may not be equipped.

MAIN DATA

8

• Main Data and Specifications	8-2
• Others	8-16
• Trailer Towing	8-27

Main Data and Specifications

Engine

4JK1 Engine Model

Specifications	
Water-cooled, overhead camshaft, direct injection engine with an inter-cooled turbocharger	
Compression ratio	(to 1) 17.0
Displacement	cc (cu. in) 2,499 (152.5)
Firing order	1-3-4-2
Fuel injection timing	Electronic control
Valve clearance (Between cam and roller)	mm (in) Both inlet and exhaust valves: 0.15 (0.006) in cold engine
Idling speed	r/min 675 - 725
Belt tension	mm (in)/Hz Fan belt: 7.7 - 8.5 (0.30 - 0.33) / 160 - 174 * New belt: 5.4 - 6.6 (0.21 - 0.26) / 188 - 210 Air conditioning compressor belt: 16.5 - 19.1 (0.65 - 0.75) / 79 - 91 * New belt: 12.5 - 16.5 (0.49 - 0.65) / 92 - 112
Oil filter	Replaceable element type
Engine oil capacity [Reference value] liters (US gal./Imp gal.)	When changing oil and filter: 2WD: 5.4 (1.43/1.19) 4WD: 5.9 (1.56/1.30)
Engine coolant capacity [Reference value] liters (US gal./Imp gal.)	Manual transmission model: 10.1 (2.67/2.22) Automatic transmission model: 10.0 (2.64/2.20)
Preheating system	Glow plugs

*: The new belt values only apply when replacing with a new belt.

RZ4E Engine Model

Specifications	
Water-cooled, overhead camshaft, direct injection engine with an inter-cooled turbocharger	
Compression ratio (to 1)	15.9
Displacement cc (cu. in)	1,898 (115.8)
Firing order	1-3-4-2
Fuel injection timing	Electronic control
Valve clearance (Between cam and roller)	No adjustments needed
Idling speed r/min	725 - 775
Belt tension	Accessory belt: Automatic adjust
Oil filter	Replaceable element type
Engine oil capacity [Reference value] liters (US gal./Imp gal.)	When changing oil and filter: 6.6 (1.74/1.45)
Engine coolant capacity [Reference value] liters (US gal./Imp gal.)	Manual transmission model: 10.1 (2.67/2.22) Automatic transmission model: 10.0 (2.64/2.20)
Preheating system	Glow plugs

Transmission

AY6 Model (Manual Transmission)

Specifications		
Six-speed transmission (overdrive gear for 6th), synchromesh for 1st to 6th and reverse		
Gear ratio (to 1)	1st	5.232
	2nd	2.644
	3rd	1.605
	4th	1.219
	5th	1.000
	6th	0.728
	Reverse	4.525
Transmission oil capacity [Reference value] liters (US gal./Imp gal.)		1.8 (0.48/0.40)

MVL6N Model (Manual Transmission)

Specifications		
Six-speed transmission (overdrive gear for 5th and 6th), synchromesh for 1st to 6th and reverse		
Gear ratio (to 1)	1st	4.942
	2nd	2.430
	3rd	1.428
	4th	1.000
	5th	0.749
	6th	0.634
	Reverse	4.597
Transmission oil capacity [Reference value] liters (US gal./Imp gal.)		2.8 (0.74/0.62)

TB-50LS Model (Automatic Transmission)

Specifications		
Five-speed automatic transmission (overdrive gear for 5th), lock-up clutch for 2nd to 5th		
Gear ratio (to 1)	1st	3.520
	2nd	2.042
	3rd	1.400
	4th	1.000
	5th	0.716
	Reverse	3.224
Transmission fluid capacity [Reference value] liters (US gal./Imp gal.)		10.7 (2.83/2.35)

AWR6B45 Model (Automatic Transmission)

Specifications		
Six-speed automatic transmission (overdrive gear for 5th and 6th), lock-up clutch for 3rd to 6th		
Gear ratio (to 1)	1st	3.600
	2nd	2.090
	3rd	1.488
	4th	1.000
	5th	0.687
	6th	0.580
	Reverse	3.732
Transmission fluid capacity [Reference value] liters (US gal./Imp gal.)	9.5 (2.51/2.09)	

Transfer

T150 Model

Specifications	
Transfer type	Chain drive
Transfer gear ratio (to 1)	1.000 (High range), 2.482 (Low range)
Transfer oil capacity [Reference value] liters (US gal./Imp gal.)	1.3 (0.34/0.29)

Gross Axle Weight (GAW) and Gross Vehicle Weight (GVW) Ratings

Specifications		
GAW: Front	kg (lb)	2WD: 1,250 (2,756) 2WD High-Ride: 1,350 (2,977) 4WD: 1,350 (2,977)
GAW: Rear	kg (lb)	1,870 (4,123)
GVW	kg (lb)	2WD: 2,900 (6,395) for Hong Kong, Singapore, and Turkey 2WD: 3,000 (6,615) for Europe and Israel 4WD: 3,000 (6,615) for Europe (left-hand drive models), Hong Kong, Israel, Singapore, and Turkey 4WD: 3,050 (6,725) for Europe (right-hand drive models)

Service Specifications

TFR86 Model

Engine	
Model	4JK1-TCY HIHI-POWER
Engine oil capacity	Refer to page 8-2
Engine coolant capacity	

Transmission	
Model	AY6
Transmission oil capacity	Refer to page 8-4

Rear axle	
Differential gear oil capacity [Reference value] liters (US gal./Imp gal.)	2.2 (0.58/0.48)

Fuel	
Fuel tank capacity [Reference value] liters (US gal./Imp gal.)	69 (18.2/15.2)

Steering	
Steering wheel free play mm (in)	10 - 30 (0.39 - 1.18)
Power steering fluid capacity [Reference value] liters (US gal./Imp gal.)	1.0 (0.26/0.22)

Wheel			
Wheel alignment	: Toe-in	mm (in)	0 (0)
	: Camber	(degree)	0°
	: Caster	(degree)	3°35'
	: King pin	(degree)	12°30'

Service brakes	
Brake pedal free play	Refer to page 6-60
Brake pedal height	Refer to page 6-60
Clearance between the brake pedal and the floor	Refer to page 6-60

Parking brake	
Lever effective stroke (Under pull force of approximately 294 N (30 kgf/ 66 lb))	6 - 9 notches

Electrical system		
Battery type	(Volt-Amp.h.)	80D26L (12 - 65), 95D31L (12 - 80)
Starter	volt-kw	12 - 2.3
Generator	volt/amp.	12/90

TFS86 Model

Engine	
Model	4JK1-TCY HIHI-POWER
Engine oil capacity	Refer to page 8-2
Engine coolant capacity	

Transmission	
Model	Manual transmission model: AY6 Automatic transmission model: TB-50LS
Transmission oil/fluid capacity	Refer to page 8-4
Transfer oil capacity	Refer to page 8-6

Rear axle	
Differential gear oil capacity [Reference value] liters (US gal./Imp gal.)	2.2 (0.58/0.48)

Front axle	
Differential gear oil capacity [Reference value] liters (US gal./Imp gal.)	1.24 (0.33/0.27)

Fuel	
Fuel tank capacity [Reference value] liters (US gal./Imp gal.)	69 (18.2/15.2)

Steering	
Steering wheel free play mm (in)	10 - 30 (0.39 - 1.18)
Power steering fluid capacity [Reference value] liters (US gal./Imp gal.)	1.0 (0.26/0.22)

Wheel			
Wheel alignment	: Toe-in	mm (in)	0 (0)
	: Camber	(degree)	0°
	: Caster	(degree)	3°20'
	: King pin	(degree)	12°30'

Service brakes	
Brake pedal free play	Refer to page 6-60
Brake pedal height	Refer to page 6-60
Clearance between the brake pedal and the floor	Refer to page 6-60

Parking brake	
Lever effective stroke (Under pull force of approximately 294 N (30 kgf/ 66 lb))	6 - 9 notches

Electrical system		
Battery type	(Volt-Amp.h.)	80D26L (12 - 65), 95D31L (12 - 80)
Starter	volt-kw	12 - 2.3
Generator	volt/amp.	12/90

TFR87 Model

Engine	
Model	RZ4E-TCX HI-POWER
Engine oil capacity	Refer to page 8-3
Engine coolant capacity	

Transmission	
Model	Manual transmission model: MVL6N Automatic transmission model: AWR6B45
Transmission oil/fluid capacity	MVL6N: Refer to page 8-4 AWR6B45: Refer to page 8-5

Rear axle	
Differential gear oil capacity [Reference value] liters (US gal./Imp gal.)	2.2 (0.58/0.48)

Fuel	
Fuel tank capacity [Reference value] liters (US gal./Imp gal.)	76 (20.1/16.7)

Steering	
Steering wheel free play mm (in)	10 - 30 (0.39 - 1.18)
Power steering fluid capacity [Reference value] liters (US gal./Imp gal.)	1.0 (0.26/0.22)

Wheel			
Wheel alignment	: Toe-in	mm (in)	0 (0)
	: Camber	(degree)	0°
	: Caster	(degree)	2WD: 3°35', 2WD High-Ride: 3°20'
	: King pin	(degree)	12°30'

Service brakes	
Brake pedal free play	Refer to page 6-60
Brake pedal height	Refer to page 6-60
Clearance between the brake pedal and the floor	Refer to page 6-60

Parking brake	
Lever effective stroke (Under pull force of approximately 294 N (30 kgf/ 66 lb))	6 - 9 notches

Electrical system		
Battery type	(Volt-Amp.h.) × No. of units	80D26L (12 - 65), 95D31L (12 - 80) (M/T) 75D26L (12 - 65) × 2, (A/T) 80D26L (12 - 65) × 2
Starter	volt-kw	12 - 1.6
Generator	volt/amp.	12/90

TFS87 Model

Engine	
Model	RZ4E-TCX HI-POWER
Engine oil capacity	Refer to page 8-3
Engine coolant capacity	

Transmission	
Model	Manual transmission model: MVL6N Automatic transmission model: AWR6B45
Transmission oil/fluid capacity	MVL6N: Refer to page 8-4 AWR6B45: Refer to page 8-5
Transfer oil capacity	Refer to page 8-6

Rear axle	
Differential gear oil capacity [Reference value] liters (US gal./Imp gal.)	2.2 (0.58/0.48)

Front axle	
Differential gear oil capacity [Reference value] liters (US gal./Imp gal.)	1.24 (0.33/0.27)

Fuel	
Fuel tank capacity [Reference value] liters (US gal./Imp gal.)	76 (20.1/16.7)

Steering	
Steering wheel free play mm (in)	10 - 30 (0.39 - 1.18)
Power steering fluid capacity [Reference value] liters (US gal./Imp gal.)	1.0 (0.26/0.22)

Wheel			
Wheel alignment	: Toe-in	mm (in)	0 (0)
	: Camber	(degree)	0°
	: Caster	(degree)	3°20'
	: King pin	(degree)	12°30'

Service brakes	
Brake pedal free play	Refer to page 6-60
Brake pedal height	Refer to page 6-60
Clearance between the brake pedal and the floor	Refer to page 6-60

Parking brake	
Lever effective stroke (Under pull force of approximately 294 N (30 kgf/ 66 lb))	6 - 9 notches



Electrical system		
Battery type	(Volt-Amp.h.) × No. of units	80D26L (12 - 65), 95D31L (12 - 80) (M/T) 75D26L (12 - 65) × 2, (A/T) 80D26L (12 - 65) × 2
Starter	volt-kw	12 - 1.6
Generator	volt/amp.	12/90

Others

Statement of Compliance with the Machinery Directive (2006/42/EC)

This vehicle's screw jack conforms to the basic requirements of the Machinery Directive (2006/42/EC) and related regulations.

Statement of Compliance

EC DECLARATION OF CONFORMITY	
 AOYAMA THAI CO., LTD.	For 
Screw Jack	
Models: Type 2WD for Isuzu D-Max, Type 4WD/2WD Highride for Isuzu D-Max	
Manufactured by Aoyama Thai Co.,Ltd. 64/49 Mu4, Eastern Seaboard Industrial Estate, Pluakdaeng, Rayong 21140 Thailand	
Means of Conformity The Product is in conformity with EC law as approximated by the following directives: Machinery Directive 2006/42/EC based on Technical Documentation File No. 2190 Issue 1, Revision 1 , November 2014	
Standards used as guidance Machinery Directive ISO12100: 2010 Limited reference to EN 1494:2000/A1: 2008 Refer to complete listing in TF	
Technical File compiled from manufacturers documentation and held in the EU, on behalf of the manufacturer by TRaC Global Ltd 100 Frobisher Business Park, Leigh Sinton Road, Malvern, Worcestershire, WR14 1BX United Kingdom	
Signature of Responsible Person:	Mr. Katsumi Buma President
	
MACHINE SERIAL No.	Date: 26 th November 2014
	Certificate No. TRA-016130-00A DoFC Issue 2

Statement of Compliance with the R&TTE Directive (1999/5/EC)

This vehicle's immobilizer conforms to the basic requirements of the R&TTE Directive (1999/5/EC) and related regulations.

Statement of Compliance



Continental Automotive GmbH – Postfach 100 953 – 93009 Regensburg

Kolar Dagmar
AQL RBG 43
Phone +49 (941) 790-6699
Fax +49 (941) 790-996699
dagmar.kolar@continental-corporation.com

Date	Your message dated	Our Reference	Your reference
May 27, 2011			

Declaration of Conformity in accordance with Directive 1999/5/EC (R&TTE Directive)

Manufacturer: Continental Automotive GmbH
Address: Siemensstrasse 12
D-93055 Regensburg
Germany
Product type designation: A2C53372320
Intended use: Vehicle Immobilizer System

The product mentioned above complies with the essential requirements and other relevant provisions of Directive 1999/5/EC, when used for its intended purpose:

Health and safety pursuant to §3.1.a:	<i>Applied standard(s):</i> EN 60950-1:2006 + A11:2009 + A1:2010
Electromagnetic compatibility pursuant to § 3.1.b:	<i>Applied standard(s):</i> EN 301 489 -1: V1.8.1 (2008-04) EN 301 489 -3: V1.4.1 (2002-08)
Efficient use of spectrum pursuant to § 3.2:	<i>Applied standard(s):</i> EN 300 330 -1: V1.7.1 (2010-02) EN 300 330 -2: V1.5.1 (2010-02)

The following marking applies to the above mentioned product:



Continental Automotive GmbH

Regensburg, 2011-05-27

.....
Andreas Wolf
Executive Vice President
Body & Security

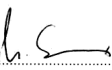
.....
Dr. Ulrich Schrey
Director CF Software
Body & Security

Continental Automotive GmbH
Siemensstr. 12
93055 Regensburg
Postfach 100 953
93009 Regensburg

Phone +49 941 790-0
Fax +49 941 790-4999
www.continental-corporation.com

Registered Office
Hanover
Registered Court
Amtsgericht Hanover
HRB 59424

General Managers
Gerard Condonner
Helmut Matsch
Harald Stuhmann

For Europe

This vehicle's keyless entry system (radio remote control units for door-lock) and passive entry and start system conform to the basic requirements of the R&TTE Directive (1999/5/EC) and related regulations.

Hereby, Panasonic Electronic Devices Co.,Ltd. declares that this keyless entry system (radio remote control units for door-lock) and passive entry and start system are in compliance with the essential requirements.

The declaration of conformity may be consulted at <http://www.doc.panasonic.de>

For the State of Israel

This vehicle's keyless entry system (radio remote control units for door-lock) conforms to the basic requirements of the Ministry of Communications (MOC) and related regulations.

- Manufacturer: Panasonic Electronic Devices Co.,Ltd.
- Model name: Keyless entry system (radio remote control units for door-lock)
- Country of manufacture: Thailand
- Importer name and address: Universal Motors Israel Ltd.

5 Faltin Naftali St.,Rishon Lezion, Israel, P.O.Box
17011 Zcode 75070

- א. השימוש במכשיר היינו על בסיס "משני" ופטור
מרשיון הפעלה אלחוטי.**
- ב. רק "בפעולת בזק" לשימוש עצמי של הלקוח בלבד,
הציוד פטור מרשיון הפעלה אלחוטי.**
- ג. אסור להחליף את האנטנה המקורית של המכשיר,
ולא לעשות בו כל שינוי טכני אחר.**

Guidelines for Installation of Aftermarket Radio Frequency Transmitting Equipment

Purpose

This installation guidelines give requirement and recommendations for the installation in vehicles of

- radio frequency (RF) transmitting equipment.
- ancillary equipment associated with these.



NOTE

- These guidelines are intended to supplement, but not to be used in place of, detailed instructions for such installations which are the sole responsibility of the manufacturer of the involved radio telephone or land mobile radio.

General

1. Only the RF-transmitting equipment and ancillary equipment (microphone, converter, booster, etc.) with 'CE' mark or 'e' may be installed in vehicle.
2. Installation of RF-transmitting equipment shall be performed by competent personal permitted by the country regulation. The vehicle and RF-transmitting equipment manufacturer's instruction manuals and installation notes shall be followed.



NOTE

- Vehicle manufacturer's instructions take priority in case of conflict.
- Installation of RF-transmitting equipment to any part of the vehicle, other than an authorized connection or mounting location, may invalidate the vehicle warranty.
- If a problem is found and can not be rectified, and it is suspected that the RF-transmitting equipment is out of specification, the appropriate manufacturer, agent or supplier shall be consulted.
- Expenses incurred from any adverse effect of any such installation are not the responsibility of vehicle manufacturer.

3. The installation shall comply with national legal requirements for the installation and use of RF-transmitting equipment in vehicles.
4. Full consideration shall be given to the positioning of RF-transmitting equipment such that electromagnetic interference (EMI) and radio frequency interference (RFI) is minimized between the RF-transmitting equipment being installed and the vehicle electrical and electronic systems.
5. Care shall be taken when planning the installation that any additional equipment used does not constitute a safety hazard and does not contravene safety regulations.
6. Care shall be taken to ensure that any microphone/handset lead is not such that the lead can interfere with the vehicle controls or driver.
7. Where a hand portable or transportable unit is installed in road vehicles, the correct car adapter kit specified for the product shall be used.

Installation

Care shall be taken in

- choosing the antenna,
- sitting it in a recommended location,
- installing it correctly,
- ensuring that all connection in the antenna feeder are sealed to prevent dirt and water from entering the feeder and affecting its performance,
- ensuring that all connection are electrically tested after installation, and
- ensuring that a satisfactory VSWR reading is obtained.

Antenna

1. For RF-transmitting equipments with output power levels above 100mW (peak), an external antenna is strongly recommended.
2. The external antenna and feeder cable shall be impedance matched with a VSWR < 2.0.
3. The antenna should be a permanent-mount type located in the roof or the rear trunk lid. If a magnet-mount antenna is used, care should be taken to mount the antenna in the same location as a permanent-mount type.



NOTE

- Each vehicle model and body style reacts to radio frequency energy differently. When dealing with an unfamiliar vehicle, it is suggested that a magnetic-mount antenna be used to check the proposed antenna location for unwanted effects on the vehicle. An antenna location is a major factor in these effects.
- The best position for an antenna is on the metallic roof, preferably towards the center, but where possible with a distance of $> \lambda/4$ (λ = wavelength) from any opening, such as a sunroof or windows.

- Care shall be taken when sitting an antenna next to an existing one or when mounting antennas with magnetic bases, as this could affect the accuracy or operation of the compass on vehicles so equipped.

[Radiation patterns and ground planes]

- In order to create a symmetrical, non-directional radiation pattern, an antenna needs to be mounted vertically on a horizontal ground plane with – ideally – a radius of $> \lambda/4$ at the lowest frequency band used (see Table 1).
- The antenna should not be located close to any electrically resonant structure.
- Care shall be taken when sitting the antenna close to another, existing antenna. It is necessary to separate them by $> \lambda/4$ for transmit frequency $f < 600$ MHz and $> \lambda$ for transmit frequency $f > 600$ MHz (see Table 1).

Table 1. Approximate frequency-to-wavelength conversion

Frequency f MHz	Wavelength λ cm	$\lambda/4$ cm
50	600	150
80	375	94
150	200	50
450	66	17
600	49.5	12
900	33	8
1800	16.5	4

[Ground-plane provision]

When the antenna installation is to be carried out on a non-metallic surface

- a ground-plane-independent antenna can be fitted directly to any surface (glass-fiber etc.) or onto a mounting bracket which may be supplied by the manufacturer,
- a standard antenna can be used with a ground plane fitted to the underside of the panel, for example a metallic plate complying with dimensions Table 1.

[Antenna position at vehicle]

Installation and use of RF transmitters with antenna outside the vehicle is shown by Table 2.

Table 2. Installation and use of RF transmitters with antenna outside the vehicle

Frequency bands (MHz)	Max. output power (W)	Antenna position at vehicle	Specific conditions for installation and/or use
1. 1.8-30	50	4.5	Ham Radio
2. 50-54	50	1.2.3.4.5	Ham Radio
3. 142-176	50	1.2.3.4.5	Ham Radio / General Service Radio
4. 380-470	50	1.2.3.4.5	Ham Radio / General Service Radio
5. 870-915	5	1.2.3.4.5	General Service Radio / Mobile Telephone
6. 1200-1300	10	1.2.3.4.5	Ham Radio
7. 1710-1785	2	1.2.3.4.5	Mobile Telephone
8. 1885-2025	1	1.2.3.4.5	Mobile Telephone

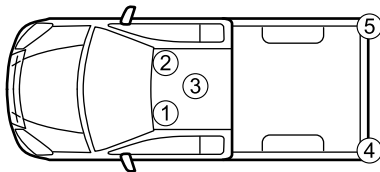

Figure 1. Drawing showing antenna installation points in the vehicle

Antenna location;

0: all location (vehicle exterior)

1: front left of roof

2: front right of roof

3: center of roof

4: left of bumper

5: right of bumper

[Case of "On-glass" antennas]

Glass mounted antennas should be kept as high as possible in the center of the rear window or windshield.



NOTE

- Care shall be taken to ensure that the glass is within the specified temperature range when fixing the antenna mount in order to obtain a good bond.

Antenna Cable

1. Use a high quality, one piece coaxial cable (at least 95% shield coverage) that is impedance matched for the RF-transmitting equipment (VSWR < 2.0).
2. Excess coaxial cable shall not be coiled, as this may affect the tuning of the antenna as well as producing electrical interference.
3. If possible, the antenna cable should be cut to the correct length.
4. The cable should be routed so as to avoid sharp bends.
5. Safety-sensitive electronic unit (e.g. airbag and ABS systems), circuits and harnesses shall not be used for parallel wiring.
6. If it is necessary to cross other wiring, cross at right angles.
7. If an extension feeder cable is required, suitable coaxial cable shall be used and correctly terminated with good quality, low-loss connectors.



NOTE

- Fit the correct antenna connectors at each end of the feeder cable to match the equipment using either crimp or soldered connectors as appropriate.

8. If the antenna cable provided is too short, wherever possible the cable should be replaced by a suitable feeder cable of correct length.



NOTE

- Extending the length of the feeder cable will result in additional losses, particularly at frequencies > 800 MHz.

9. Ensure that the feeder cable is not strained or distorted by, for example, excessive tightening of cable ties.
10. When vehicle trim is replaced, make sure that the panels do not trap the feeder cable.
11. Additional care should be taken when installing a glass mount to the rear screen of a hatch-back type vehicle to allow opening and to prevent damage to the feeder cable.

RF-transmitting Equipment

[Mounting of RF-transmitting equipment]

1. Location of a RF-transmitting equipment should be selected that provides a solid mounting point which does not interfere with the vehicle operator controls and provides adequate ventilation.
2. RF-transmitting equipment shall not be able to be damaged or its ventilation restricted. Special care should be taken to ensure that RF-transmitting equipment can not be damaged by ingress of water.
3. Access to vehicle equipment in the load storage area shall not be barred, e.g. by wheel jack, fire extinguishers or spare wheel.
4. The connections to the RF-transmitting equipment should be easily accessible in order that the equipment may be removed for operation in transportable mode, or for repairs and servicing.
5. It shall not hinder the operation of airbags or other safety equipment.



NOTE

- Great care should be taken not to mount any RF-transmitting equipment, microphones or any other item in the deployment path of a Supplemental Inflatable Restraint or "Air Bag."

[Routing of RF-transmitting equipment's cables]

1. Where possible, all cables should pass inside or underneath trim and through moldings in such a way as to afford maximum protection. If necessary, use sleeving, a proprietary protector and/or cable ties where required.
2. Select a route for the cable, ideally on the opposite side of the vehicle to the fuel pipe, clear of brake pipes, cables, controls, vehicle wiring and any hot components. Under no circumstances shall any cables be attached to the foregoing.
3. Cable shall be routed so that they avoid
 - sharp edges,
 - continual bending,
 - stress or strain,
 - abrasion,
 - extreme temperature, and
 - becoming a hazard to the occupants of the car.

Power Supply for RF-transmitting Equipment

[General]

1. A dedicated supply cable should be used for the RF-transmitting equipment installation which should be as short as possible to the battery positive and negative connections. Do not connect directly to the battery pillars, but use the battery terminals provided.



NOTE

- Connections shall not be made to any electronic control unit feeds under any circumstances. For example, avoid using cigar lighter as power sources for a RF-transmitting equipment.

2. It is also recommended that, unless a molded twin supply cable is used, the two supply lines be twisted together along their length in order to reduce radiated noise or induce noise.



NOTE

- The supply cable from the RF-transmitting equipment should approach the battery in such a way that, when terminated, the two wires can not be inadvertently reversed, e.g. one wire is shorter than the other.

3. If ignition switch control is desired, the handset or control unit positive lead may be connected through an appropriate in-line fuse to an available accessory circuit or ignition circuit not powered during cranking.

[Supply cable and routing]

1. Heavy-duty cable of a low electrical resistance should be used on long cable runs to minimize voltage drop.
2. The cable shall be of a higher current capacity than the protection fuse, and the correct fuse shall be fitted.
3. The cable should be as short as possible.
4. The cable shall be secured well clear of moving parts, (shock absorbers, steering, drive shaft, control pedals, etc.).
5. The cable shall be secured well clear of the engine, exhaust system or other hot items.
6. The supply cable run should, where possible, be separate from that of the in-car entertainment equipment control cables, although they may pass through the same holes in the chassis and body for ease of fitting; suitable grommets should be fitted if additional holes are drilled.
7. The cable shall be supported, avoiding sharp bends, and shall not be subjected to strain.
8. The cable shall be sited away from ignition coil, the high voltage circuits of the ignition systems and electronic control units and, where possible, other vehicle wiring.

Statement of Compliance with UN R13 (ECE R13)

Information required by European brake regulation UN R13 (ECE R13) is disclosed on the following website.

URL: <http://www.isuzu.co.jp/world/index.html>

Trailer Towing

The vehicle is designed for passenger and cargo transportation, however, when using the appropriate equipment, you can tow a trailer under certain conditions.

Towing a trailer has a significant influence on handling, performance, braking, durability and fuel consumption.

For your safety and that of others too, use equipment specifically designed for your vehicle. Improper equipment or installation can cause damage to your vehicle and possibly personal injury. Additional care and cautious driving habits are essential when towing a trailer.

Damage or malfunction caused by towing a trailer for commercial purposes are not covered by Isuzu warranties.

When a new vehicle has been driven or when a vehicle that has had powertrain parts changed (engine, transmission and differential) to new parts, it is recommend not to tow the vehicle until the driving distance reaches 800 km (497 miles).

When towing a trailer, the following gross trailer weight (trailer weight plus cargo load) shown in the table must not be exceeded.

2WD models

	Gross trailer weight
Trailer hitch kit	2,500 kg (5,513 lb)

4WD models

	Gross trailer weight
Trailer hitch kit	3,500 kg (7,718 lb) (models for the European, Israel, and Turkey markets) 3,000 kg (6,615 lb) (models for the Hong Kong and Singapore markets)

The trailer hitch kit is available from your Isuzu Dealer. The trailer hitch kit contains the trailer hitch, bracket and hardware.

Additional equipment for trailer brake systems will be required. The additional equipment can be purchased at a recreational vehicle dealer.

Follow the recommendations in this manual before towing a trailer. For further details, contact the nearest Isuzu Dealer.

Gross trailer weight
(GTW)

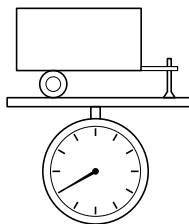

 **WARNING**

- The loading and weight limitations shown below must be followed for your continued driving satisfaction.
 - The gross trailer weight (trailer weight plus cargo load) must never exceed the designed towing capacity of the vehicle. The maximum weight limit for vehicles equipped with a trailer hitch kit is as follows:
 - 2WD model: 2,500 kg (5,513 lb)
 - 4WD model:
 - 3,500 kg (7,718 lb) (models for the European, Israel, and Turkey markets)
 - 3,000 kg (6,615 lb) (models for the Hong Kong and Singapore markets)Exceeding the weight limits is dangerous. It will cause damage to your vehicle and possibly result in personal injury.
 - The gross combined weight (GCW) rating equals the combined weight including passengers and cargo of your vehicle plus the total trailer load. The following limitations apply.
 - 2WD model:
 - 5,500 kg (12,128 lb) (models for the European and Israel markets)
 - 5,400 kg (11,907 lb) (models for the Hong Kong, Singapore, and Turkey markets)
 - 4WD model: 6,000 kg (13,230 lb)
- WARNING (Continued)

WARNING (Continued)

- The gross vehicle weight (GVW) rating equals the combined weight of an unloaded vehicle, passengers, cargo, trailer hitch, trailer tongue load and optional equipment. This value is indicated on the vehicle identification number (VIN) plate attached to the left front end of the engine compartment.
- The gross axle weight (GAW) rating values are also indicated on the vehicle identification number (VIN) plate. The load on either the front or rear axles resulting from distribution of the gross vehicle weight on both axles must not exceed the values listed on the vehicle identification number (VIN) plate. Remember to account for additional equipment and the tongue load.
- Be sure not to allow the tongue load to exceed:
2WD model: 100 kg (221 lb)
4WD model: 245 kg (540 lb)
Never exceed the maximum weight limits of the trailer or trailer towing equipment. Improper loading can result in damage to your vehicle and possible personal injury. Check weights and loading at a commercial scale or highway patrol office that is equipped with scales.

Tongue load

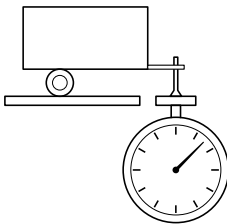
**CAUTION**

- Never exceed the weight limits indicated above.

Equipment

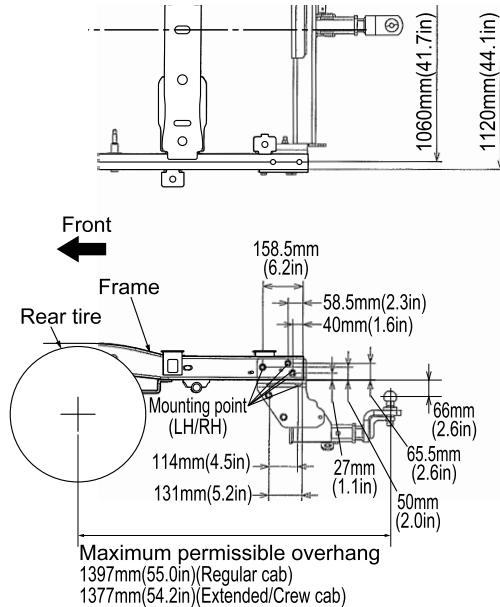
**Trailer Hitch**

The trailer hitch kit is available from your Isuzu Dealer. The kit includes all the necessary hardware and instructions for proper installation.

See the drawing for the mounting points of the coupling device and the maximum permissible overhang of the coupling device.

Check with your recreational vehicle dealer for additional required equipment.

Only a trained mechanic should install your vehicle towing equipment.

Do not use axle-mounted hitches or equipment not designed for your vehicle.

Do not modify the electrical systems of the vehicle to accommodate towing a trailer other than those specified in the instructions contained in the Isuzu trailer hitch kit.

Improper modifications can affect vehicle durability.

Improper equipment or installation can cause damage to your vehicle and possible personal injury.

After installation of the Isuzu trailer hitch kit is complete, periodic inspections of the equipment are necessary to assure continued safe operation.

Safety Chain

Always use a safety chain that is suitable for your vehicle and trailer. Check with your trailer manufacturer regarding the required equipment. Cross the safety chain under the hitch and attach it to the trailer hitch connections.

The safety chain will prevent the trailer from dropping to the ground in the event that the hitch disengages. For proper use and installation, consult the trailer manufacturer.

Trailer lights

Trailer lights and equipment should comply with local legal requirements. Check with your recreational vehicle dealer for the specific requirements. Use only equipment that is designed for your vehicle. Improper equipment or installation can cause damage to the electrical system of your vehicle and affect your vehicle warranty. Consult your Isuzu Dealer for installation.

Tires

Always check the condition of the tires of the vehicle and trailer before operation. Replace worn or damaged tires before operation.

Inflate tire pressure to the recommended cold tire pressure indicated on the tire pressure label on the driver's door opening frame and according to the values recommended by the manufacturer of your trailer.

When the vehicle is towing a trailer and the GAW is 1,870 kg (4,123 lb) or more, the vehicle should be driven at 60 km/h (37 MPH) or under. For the vehicle equipped with 215/70R15C, 245/70R16, 255/65R17, or 255/60R18 tires, their rear tire pressure should set as specified below:

215/70R15C → **440 kPa** (4.40 kg/cm² / **64 psi**)

245/70R16 → **290 kPa** (2.90 kg/cm² / **42 psi**)

255/65R17 → **260 kPa** (2.60 kg/cm² / **38 psi**)

255/60R18 → **280 kPa** (2.80 kg/cm² / **41 psi**)

Trailer Brakes

Trailers with a gross weight of 750 kg (1,654 lb) or more require trailer brakes. If your trailer is equipped with a braking system, make sure it conforms to local legal requirements.

WARNING

- Never connect a trailer braking system to your vehicle braking system. Braking efficiency and operation will be seriously affected.

Consult your trailer manufacturer and an Isuzu Dealer for proper installation and use of trailer brakes.

Equipment Check

Before operating your vehicle, check all safety equipment to ensure safe operation. Be sure your vehicle is properly serviced to avoid a mechanical malfunction.

Be sure trailer cargo is securely loaded. Check that your rear view mirrors conform to local legal requirements.

Perform an equipment check of all braking, lighting and safety equipment to ensure they are working properly.

Your safety depends on proper operation and installation of equipment. Never operate a vehicle with malfunctioning equipment.

Supplementary exterior rear view mirrors should be added to the vehicle if the traffic to the rear cannot be seen clearly with standard mirrors. Adjust the extending arms of these mirrors on both sides of the vehicle so that they always provide maximum visibility of the road behind.

Maintenance

Towing a trailer will affect vehicle maintenance requirements due to the additional load. More frequent maintenance intervals will be required to assure continued satisfaction with the vehicle. Regarding the recommended maintenance and service, contact the nearest Isuzu Dealer.

A

Accessory Socket	5-34
Air Cleaner	6-50
Air Outlets	5-2
Antenna	5-49
Anti-lock Brake System (ABS)	4-158
Anti-theft System	3-20
Ashtray	5-37
Automatic Air Conditioner	5-4
Automatic Transmission Fluid (Automatic Transmission Model)	6-91
Automatic Transmission Model	2-42

B

Before Driving	2-2
Bottle Holder and Small Article Storage Pocket (Front and Rear Doors)	5-47
Brakes	6-58

C

Calendar Display	4-25
Carrying Children	2-21
Cautions for Driving in Cold Regions	2-58
Cautions for Driving in Hot Regions	2-57
Center Console Box	5-43
Changing Tires	6-79
Checking Components that Showed Abnormalities during Previous Operation	6-16
Child Restraint System (CRS)	3-68
Child-proof Door Locks (Crew Cab Model)	3-34
Cigarette Lighter	5-32
Clock Display	4-25
Clutch (Manual Transmission Model)	6-90
Coat Hook	5-48
Combination Light Control Switch	4-121
Cruise Control	4-153
Cup Holder	5-44
Cup Holder and Small Article Storage Pocket	5-45

D

Daily Checks (Preoperational Checks)	6-14
Dashboard Tray	5-41
Diesel Particulate Defuser (DPD)	2-73, 4-184
Discarded Parts, Oils and Other Liquids	6-6
Driving	2-23

E

Electronic Braking force Distribution (EBD)	4-162
Electronic Stability Control (ESC)	4-163
Emergency Engine Starting (Models with Passive Entry and Start System)	7-11
Emergency Engine Stopping (Models with Passive Entry and Start System)	7-10
Engine Conditions	6-18
Engine Coolant	6-40
Engine Coolant Temperature Gauge	4-22
Engine Hood	6-10
Engine Oil	6-20
Engine Start/Stop Button (Models with Passive Entry and Start System)	4-116
Exterior (PICTORIAL INDEX)	0-15
Exterior Maintenance	6-114

F

Fan Belt/Air Conditioning Compressor Belt/Accessory Belt	6-47
Four Wheel Drive (4WD) Model	2-46, 4-176
Front Fog Light Switch	4-125
Front Seat Belt with Pretensioner and SRS Airbag System	2-77, 3-80
Fuel Filter	6-53
Fuel Gauge	4-23
Fuel Tank Filler Cap	3-45

G

Gearshift Lever	4-138
Getting In and Out of the Vehicle	3-38
Glove Compartment	5-40
Grip	5-47

H

Handling the Battery	6-101
Handling the Jack	6-74
Handling the Radiator and Intercooler	6-45
Hazard Warning Flasher Switch	4-126
Headlight Leveling Switch	4-124
Headlights and Turn Signal Lights	6-100
Heated Seat Switch	4-132
Heater/Manual Air Conditioner	5-15
Hill Descent Control	4-172
Hill Start Assist	4-170
Horn Button	4-129
How to Read the Instruments (Instruments Layout)	4-16

I

Illumination Control Switch	4-131
Illumination of Center Display	4-28
Inspection and Maintenance	6-122
Interior (PICTORIAL INDEX)	0-6
Interior Lights	5-26
Interior Maintenance	6-117
Isuzu Genuine Oils and Grease	6-6

K

Key	3-2
Key with Immobilizer Transponder Chip	3-4

L

Liquid Crystal Display (LCD)	4-62
------------------------------	------

M

Main Data and Specifications	8-2
Manually Operated Windows	3-44
Mirrors	3-59
Model with Automatic Transmission	4-143
Multi-Information Display (MID)	4-30

O

Odometer and Trip Meter	4-18
Off-road Driving	2-41
Opening and Closing Doors	3-25
Others	8-16
Overhead Console	5-30

P

Parking Brake	6-63
Parking Brake Lever	4-137
Passive Entry and Start System/Keyless Entry System (Radio Remote Control Units for Door-lock)	3-7
Pedals	4-136
Power Steering Fluid	6-93
Power Windows	3-39
Precautions for Checking and Adjustments	6-4
Preventing Breakdowns	2-66

R

Rear Fog Light Switch	4-125
Rear Vision Camera	5-52
Rear Window Defogger Switch	4-133
Refrigerant	6-112
Remote Control Mirror Switch	4-129
Replacing the Fuses and Relays	7-46
Retractable Power Mirror Switch	4-130

S

Seat Belts	3-61
Seats	3-48
Selector Lever	4-141
Small Article Storage Pocket	5-38
Small Article Storage Pocket (Driver's Side)	5-42
Small Article Storage Pocket (Passenger's Side)	5-39
Small Article Storage Pocket (Upper Side of Dashboard)	5-41
Spare Tire	6-70
Speed Limit Device	2-76
Speedometer	4-18
Starter Switch (Models without Passive Entry and Start System)	4-119
Starting the Engine	4-4
Staying Safe	2-62
Steering Wheel	6-92
Steering Wheel Remote Control	5-51
Stopping and Parking	2-49
Stopping the Engine	4-12
Sun Visor	5-31

T

Tachometer	4-21
Tailgate	3-35
Ticket Holder	5-31
Tilt Steering	3-58
Tire Rotation	6-69
Tools	6-7
Towing	7-57
Trailer Towing	8-27
Troubleshooting	7-2
Turbocharger	2-82

U

USB Power Outlet	5-35
Using Tire Chains	2-72

V

Vanity Mirror	5-32
Vehicle Data Collection	2-82
Vehicle Identification Number (VIN) and Engine Number	1-2

W

Warm-up System	4-11
Warning and Indicator Lights	4-70
Warning and Indicator Lights Layout	4-26
Warning Buzzer	4-111
Warning/Caution Labels in Your Vehicle	0-26
Warning/Indicator Light Index	0-16
Wheels and Tires	6-63
When Driving on Bad Roads	7-56
When the Battery Goes Flat	7-26
When the Brakes Do not Work	7-25
When the Bulb Does not Come On	7-34
When the Electronic Key Battery Goes Flat	7-7
When the Engine Oil Pressure Warning Light Comes On	7-31
When the Engine Overheats	7-32
When the Engine Stalls and Cannot be Restarted	7-25
When the Engine Stops While Driving	7-24
When the Fuel Runs Out	7-28
When the Generator Warning Light Comes On	7-30
When the Tire Goes Flat	7-13
When the Vehicle Breaks Down during Driving	7-12
When the Warning Light Comes On	7-31
When to Visit Your Isuzu Dealer	2-69
Windshield Washer Fluid	6-96
Windshield Wiper and Windshield Washer Switch	4-127
Windshield Wiper Blades	6-97

MEMO

MEMO

MEMO

MEMO